

SOLUCIONES PARA LA EVACUACIÓN DE HUMOS

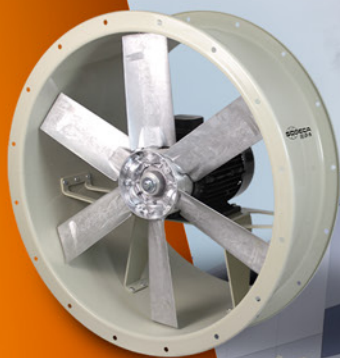

EN-12101-3
POWERED SMOKE AND HEAT
EXHAUST VENTILATORS FOR USE
IN CONSTRUCTION WORKS





SODECA ofrece soluciones en ventilación industrial,
evacuación de humos, presurización de escaleras y mejora
de la calidad del aire interior.





Los procedimientos de calidad utilizados y certificados según ISO 9001:2015 sitúan al Grupo SODECA como a uno de los más reconocidos fabricantes de ventiladores a nivel mundial.

Como resultado del proceso de expansión y consolidación de la actividad de la empresa, en 2018, se inaugura la nueva sede ubicada en Ripoll, municipio cercano a Barcelona.

Estas nuevas instalaciones cuentan con más de 15.000 m² de superficie, repartidos entre oficinas, atención al cliente, almacén y producción.

A día de hoy, SODECA se ha convertido en uno de los líderes internacionales en el sector de la ventilación, principalmente por las soluciones que ofrece de protección contra incendios en la especialidad de evacuación de humos y presurización de escaleras y vías de evacuación.

SISTEMAS PARA CONTROL DE HUMO EN CASO DE INCENDIO

“El 80% de las víctimas en un incendio son causadas por los efectos nocivos del humo: toxicidad en inhalación, temperatura, asfixia y falta de visibilidad.”

El control de humo en caso de incendio **juega un papel primordial en la evacuación de las personas y la intervención de los servicios de extinción, ayudando a crear zonas libres de humo o asegurando unas condiciones de temperatura y visibilidad adecuadas en cada caso.** Asimismo, si el humo es controlado, se protegen los bienes materiales, cerramientos y estructura del edificio, permitiendo una reanudación más rápida de la actividad.

Para poder asegurar unas óptimas prestaciones de control de humo, **es necesario que el sistema de control de humo en caso de incendio se ejecute con equipos que garanticen su funcionamiento** en las condiciones de temperatura y tiempo de funcionamiento previsto, pero también es necesario que dicho sistema haya sido diseñado siguiendo las normas existentes o especificaciones técnicas de diseño de reconocido prestigio, y que la gestión de los distintos equipos que conforman el sistema se realice correctamente.

Para asegurar el funcionamiento de los extractores para la evacuación del humo, **todas las soluciones de SODECA cuentan con marcado CE conforme a la Norma Europea EN 12101-3:2015. Smoke and heat control systems - Part 3: Specification for powered smoke and heat control ventilators (Fans).**



Para el correcto diseño del sistema de control de humo de incendio, **SODECA cuenta con un Departamento de Proyectos formado por técnicos especializados que ofrecen asesoramiento personalizado** desde la fase inicial del proyecto, aportando un completo estudio técnico que incluye:

- Cálculos de dimensionado
- Los planos de ubicación de los equipos
- La lógica de funcionamiento del sistema
- La especificación de todos los equipos integrantes del mismo

Incluyendo los ventiladores de extracción de humo, ventiladores de aportación de aire exterior, compuertas de control de humo y cuadros de control para la gestión del sistema.

REFERENCIAS SODECA

SODECA ha contribuido en aportar soluciones de ventilación para la extracción de humos en infraestructuras emblemáticas a nivel internacional.



VENTILACIÓN DE APARCAMIENTO
Hotel Sheraton Grand Tbilisi Palace, Georgia



VENTILACIÓN DE APARCAMIENTO
Centro comercial Madrid RIO, España



EVACUACIÓN DE HUMOS
Romsdal High School, Norway

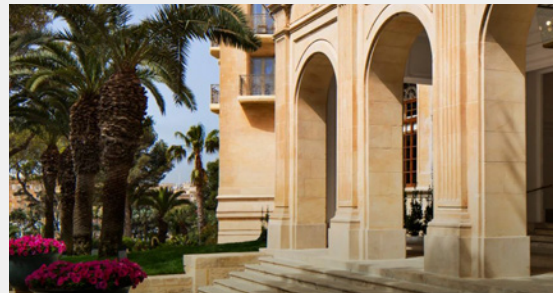

PRESURIZACIÓN DE ESCALERAS
Phoenicia Hotel *****, La Valeta



DEPRESURIZACIÓN DE ESCALERAS
Penrose Dock, Irlanda



EVACUACIÓN DE HUMOS
Silo Inditex, Madrid



CUMPLIENDO ESTÁNDARES INTERNACIONALES

SISTEMA DE GESTIÓN DE CALIDAD

SODECA dispone de un Sistema de Gestión de Calidad, certificado según la ISO 9001:2015 por Bureau Veritas, que acredita la capacidad de la empresa para planear, ejecutar y controlar los procesos necesarios para el desarrollo de su actividad, obteniendo como resultado la satisfacción del cliente gracias a la entrega de productos fabricados con altos estándares de calidad.

Una empresa comprometida con la fiabilidad y garantía de sus equipos que están instalados en lugares de difícil acceso y son elementos del sistema de seguridad en caso de incendio.

Por ello, se verifican todos los puntos críticos del proceso de fabricación mediante un riguroso control de gestión interno:

- Certificaciones del **material primario** (chapas de acero)
- Certificado de los **tratamientos anticorrosivos**
- Revisión de los **procesos de fabricación**
- **Equilibrado de hélices y turbinas**
- Comprobación del **consumo de los motores**



Certificados de temperatura (EN 12101-3)

Los sistemas de ventilación de SODECA están diseñados con un doble propósito: para la ventilación diaria (confort) y para la ventilación de emergencia (situación de incendio). En caso de incendio, el sistema de ventilación controla la propagación del humo y calor. Por este motivo, todos los equipos están certificados según la EN 12101-3 en laboratorios acreditados e independientes.



Ensayos de prestaciones (ISO 13500- ISO 5801)

Los equipos se someten a rigurosos ensayos a escala real para comprobar las prestaciones del ventilador (caudal y presión, empuje, vibraciones, niveles acústicos, etc.). Estos se realizan de acuerdo con las normativas internacionales (ISO 13500- ISO 5801).





ENSAYO DE VENTILADORES Y FACTORY ACCEPTANT TEST (FAT)

Los criterios de rendimiento de los ventiladores son esenciales para asegurar la correcta aplicación del sistema de ventilación en el túnel. Por ello, SODECA es riguroso con las prestaciones de los equipos y para lograr las prestaciones de los ventiladores trabaja con una metodología de pruebas, procedimientos de ensayo, así como normas de reconocido prestigio ISO 13350, ISO 5801.

- Consumo del motor
- Presión
- Niveles acústicos
- Caudal
- Empuje
- Vibraciones



Factory
Acceptance
Test

El cliente dispone de la posibilidad de validar las prestaciones y el buen funcionamiento del equipo realizando una prueba real del ventilador y equipos suministrados en nuestras instalaciones.



INVESTIGACIÓN Y DESARROLLO

La investigación y desarrollo es una constante para la mejora continua de los equipos con el objetivo de conseguir seguridad, durabilidad y un bajo mantenimiento con elevados niveles de eficiencia (ERP 2015). Los sistemas de ventilación de SODECA para túneles se realizan a medida según los requisitos del proyecto gracias a un gran equipo de profesionales con Know-how y tecnología de altas prestaciones como garantía de seguridad y calidad de los productos.

SOLUCIONES DE APOYO AL CLIENTE



CONSULTORÍA Y DISEÑO

Con el fin de ofrecer un servicio integral, SODECA ofrece soporte de consultoría, diseño y estudios personalizados.



SIMULACIÓN COMPUTACIONAL CFD

Disponemos de las herramientas de simulación computacional CFD más avanzadas y la experiencia necesaria en su uso. Este estudio permite verificar que se cumplen los parámetros de funcionamiento del sistema como el comportamiento del humo, los valores de temperatura, la visibilidad, la velocidad del aire, o la concentración de gases.



Software de cálculos

QuickFan, el software para obtener cálculos y elaborar proyectos de ventilación. Seleccionar el producto más adecuado para su instalación de ventilación ahora es más fácil que nunca.

¡Házlo fácil con QuickFan!



Modelos 3D

A través del módulo de proyectos para QuickFan y la descarga de los diseños en CAD 3D o REVIT, podrá diseñar proyectos de ventilación, realizar cálculos y obtener informes técnicos completos en pocos minutos.



Ventiladores Formato BIM

Ahorrar tiempo y recursos en la gestión de proyectos es posible gracias al sistema BIM para más de 5.200 modelos de ventiladores. Este formato incorpora características e información técnica adicional al modelo y mejora el control de la ejecución de una obra.

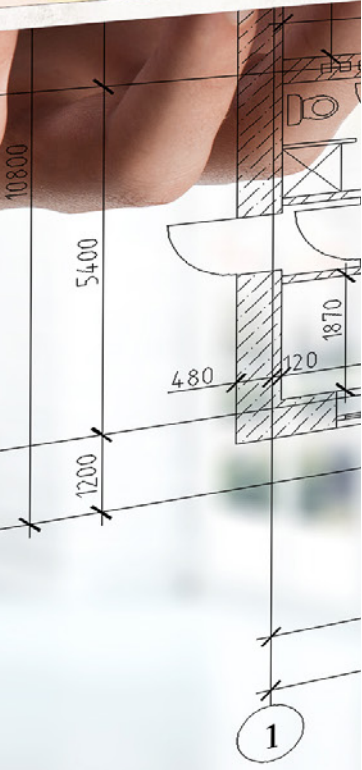

SISTEMAS PARA CONTROL DE HUMO EN CASO DE INCENDIO

- APARCAMIENTOS
 - NAVES INDUSTRIALES Y EDIFICIOS DE PÚBLICA CONCURRENCIA
 - CÁMARAS FRIGORÍFICAS
 - VÍAS DE EVACUACIÓN
 - TÚNELES
- 
- 



APARCAMIENTOS

Es indispensable que el sistema de ventilación para aparcamientos sea **fiable a lo largo de los años para proporcionar seguridad a los usuarios.**

En los aparcamientos la ventilación puede ser natural o forzada. En este último caso, **es necesario instalar ventiladores para generar el movimiento de aire**

adecuado y poder mantener las condiciones de seguridad y confort requeridas en condiciones habituales o también en caso de incendio.

FUNCIONES DE LA VENTILACIÓN PARA APARCAMIENTOS

El sistema de ventilación en aparcamientos cubre una triple función:



Gestionar el humo en caso de incendio, tanto para facilitar la evacuación de los ocupantes como para ayudar en la intervención de los servicios de extinción.



Mantener controlada la **concentración de los gases contaminantes** emitidos por los vehículos.



Mantener controlada la **concentración de gases explosivos** generados por una posible fuga de combustible de los vehículos.

Las tres funciones se integran en un único sistema capaz de proporcionar un caudal adaptado a las necesidades en cada momento con la finalidad de optimizar el consumo energético del sistema.

SISTEMAS DE VENTILACIÓN EN APARCAMIENTOS

VENTILACIÓN MECÁNICA
MEDIANTE REDES DE CONDUCTOS

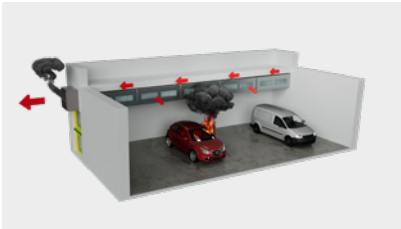

VENTILACIÓN MECÁNICA
ASISTIDA POR VENTILACIÓN POR IMPULSO



VENTILACIÓN NATURAL ASISTIDA
POR VENTILACIÓN POR IMPULSO



SOLUCIONES



INMERSO

Instalación del ventilador inmerso en la zona de riesgo de incendio



THT



CJHT/PLUS



CJHT/ATEX



THT/HATCH



CJBTD



CBTD



TCR



THT/WALL-F



CJS



CJMD



EXTERIOR

Instalación del ventilador exterior a la zona de riesgo de incendio



TCR/R



CJTCR/R



TCMP



CJMP



CJTX-C



CJSX



CJSRX



CJLINE



JET FAN

Instalación del jet fan en la zona de riesgo de incendio



THT/IMP-O



THT/IMP-L



CI



NAVES INDUSTRIALES Y EDIFICIOS DE PÚBLICA CONCURRENCIA

Las soluciones para la evacuación de humo limitan los efectos de calor y evacuan el humo generado en caso de incendio.

Estos sistemas de ventilación pueden **extraer los gases calientes generados al inicio de un incendio y crear áreas libres de humo por debajo de las capas de humo flotante**, favoreciendo así las condiciones de evacuación y facilitando las labores de extinción. También se evita la aparición de focos de fuego secundarios y el control de la temperatura de los humos para evitar el colapso del edificio.

Para que se cumplan todas estas ventajas, **es esencial que los ventiladores de extracción de humos y calor sean fiables y funcionen perfectamente** durante toda su vida útil siempre que se les requiera.

Un sistema de evacuación de humos se debe proyectar y dimensionar para alcanzar uno o varios de los siguientes objetivos:



Protección de los medios de evacuación



Control de la temperatura de los gases



Ayuda a las operaciones de lucha contra incendios



Protección de las estructuras de los edificios

El uso de los sistemas de evacuación de humo en caso de incendio está previsto para diversos tipos de edificios y aplicaciones, incluyendo: edificios industriales de una o varias plantas o con entreplanta; almacenes paletizados o con almacenamientos en estanterías;

centros comerciales con una o varias plantas; atrios y edificios de geometría compleja; edificios de entretenimiento y pública concurrencia; y también espacios no compartimentados en edificios con más de una planta.

SISTEMAS DE VENTILACIÓN EN NAVES INDUSTRIALES Y EDIFICIOS DE PÚBLICA CONCURRENCIA

EVACUACIÓN DE HUMOS EN EDIFICIOS DE UNA SOLA PLANTA

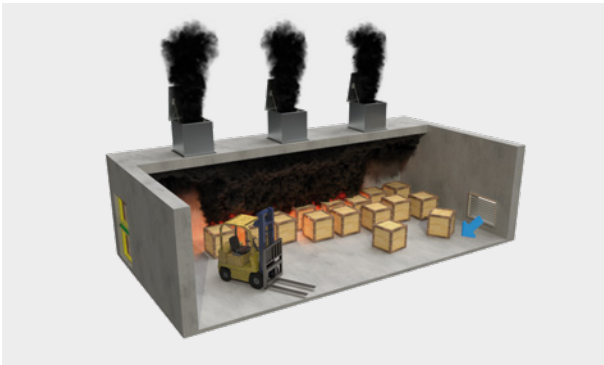

EVACUACIÓN DE HUMOS EN EDIFICIOS MULTI NIVEL



SOLUCIONES



HTMF



THT/ROOF



THT/HATCH



THT/WALL



CVT



CHT



CJTHT



THT



SCDLS-MA



SCDLM-MA



SCDRS-MA



CÁMARAS FRIGORÍFICAS

La implementación de un sistema de control de humo en caso de incendio en cámaras frigoríficas presenta singularidades respecto a los sistemas de control de humos instalados tradicionalmente en naves industriales, en concreto:

La **existencia de un doble techo** (techo de la cámara y cubierta de la nave) genera la dificultad de trasladar del interior de la cámara frigorífica hacia el exterior, los humos generados por un incendio.

Los equipos que se instalan en la envolvente de la cámara frigorífica **precisan de prestaciones de aislamiento térmico para evitar elevadas pérdidas energéticas.**

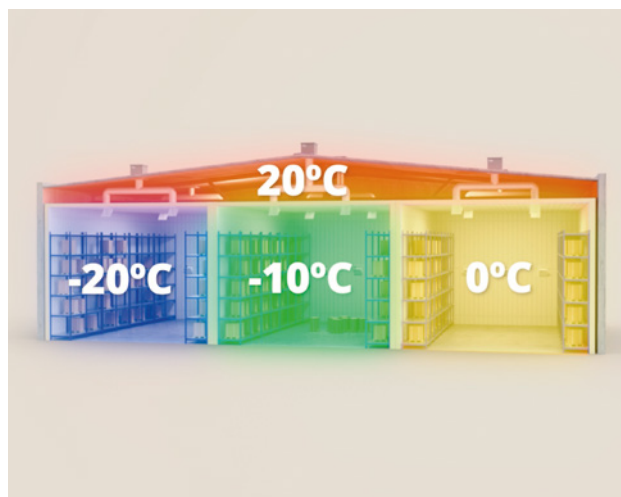

La existencia de bajas temperaturas en el interior de la cámara frigorífica pueden reducir la flotabilidad de los humos y dificultar su evacuación. Por este motivo, los sistemas de extracción mecánica se presentan como la opción que aporta mejores garantías de funcionamiento.

SISTEMAS DE CONTROL DE HUMO EN CÁMARAS FRIGORÍFICAS

**EVACUACIÓN DE HUMOS
DIRECTA DESDE LA CÁMARA
FRIGORÍFICA**



**EVACUACIÓN DE HUMOS
POR PLENUM**

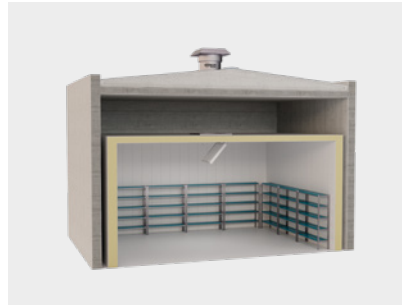

**EVACUACIÓN DE HUMOS
CONDUCTADA DESDE LA CÁMARA
FRIGORÍFICA**

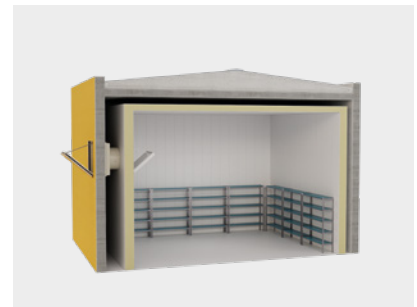
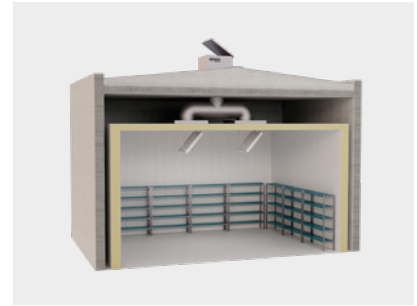

SOLUCIONES



THT/WALL



THT/WALL-F



THT/HATCH



HTMH



HTMV

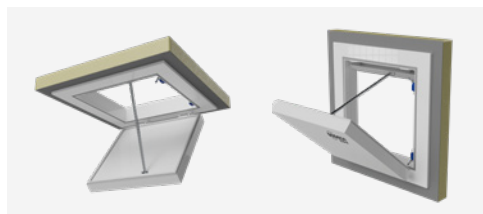

FRIDGE/FLAP

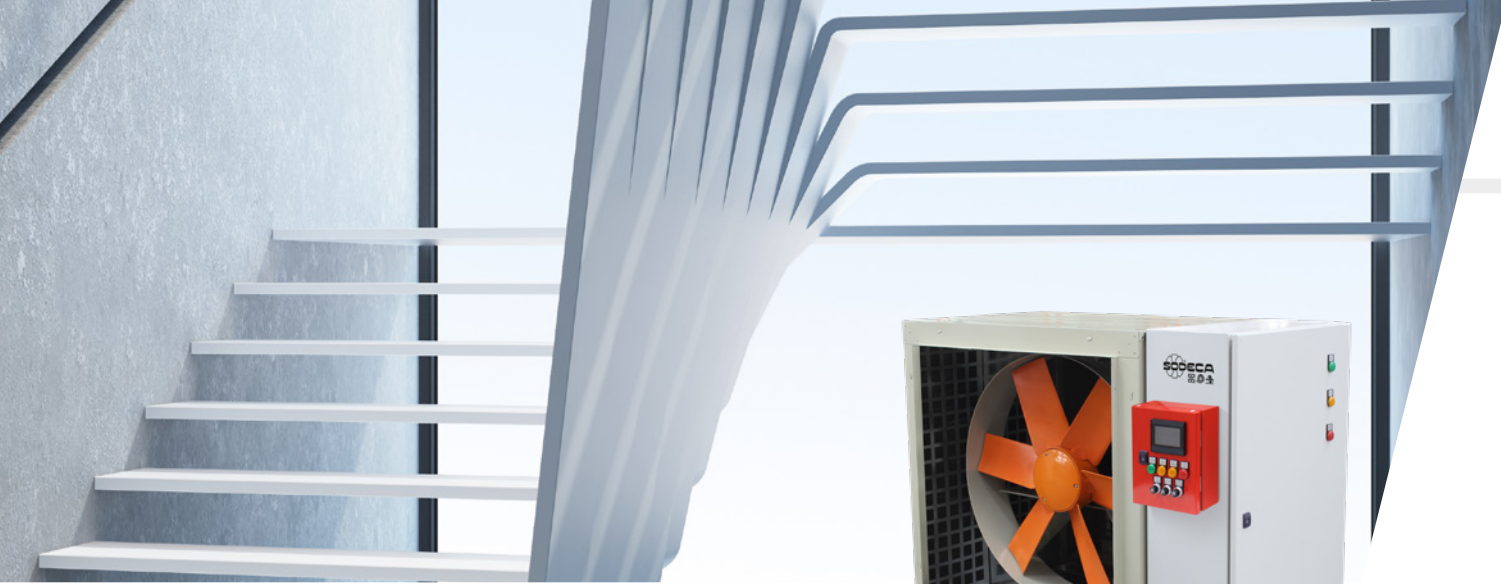

VÍAS DE EVACUACIÓN

Los sistemas de control de presurización protegen las vías de evacuación en caso de incendio evitando la entrada de humo mediante una sobrepresión de aire. En caso de apertura de puertas o de fugas

de aire, el sistema reacciona aumentando el caudal. De este modo se garantiza que las vías de escape siempre estén libres de humo en una situación de emergencia.

FUNCIONES DEL SISTEMA DE PRESURIZACIÓN PARA VÍAS DE EVACUACIÓN



Está dotado de todos los elementos necesarios para su correcto funcionamiento de acuerdo con la normativa EN 12101-6 (ventilador, sonda de presión, compuerta, variador, PLC, etc.)



Permite controlar de forma automática el caudal en caso de puerta abierta (criterio de velocidad) y mantener una presión diferencial mínima (50 Pa) en situación de puerta cerrada según los requisitos de la norma europea EN 12101-6.



Dispone de conexión al sistema de gestión del edificio (BMS - Building Management System o SCADA) y conexión remota del estado de todos los equipos según modelo. Además, se puede incorporar un cuadro de comunicación remota para bomberos u otros usuarios.



El sistema dispone de activación en modo seguro a partir de la señal de alarma de incendio y modo seguro de funcionamiento para apertura de puertas en caso de exceso de sobrepresión.



Puede realizar la gestión de la toma de aire mediante compuerta motorizada y detector de humo.



Se entregan integrados y listos para su funcionamiento (sistema Plug&Play).



El cuadro de control dispone de pilotos indicadores de estado y selector de activación automática o manual del sistema.

ASPIRACIÓN DEL AIRE EXTERIOR

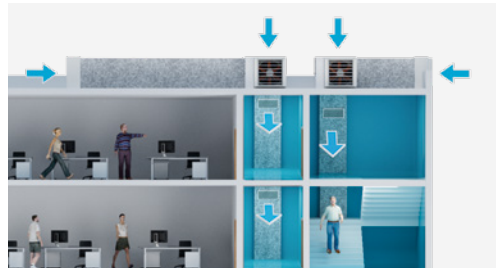

ESCAPE DE AIRE DE PRESURIZACIÓN



**PRESURIZACIÓN DE VESTÍBULOS
PRESURIZACIÓN CONJUNTA DE TODOS LOS VESTÍBULOS**



**PRESURIZACIÓN DE VESTÍBULOS
PRESURIZACIÓN INDIVIDUAL DE VESTÍBULOS**

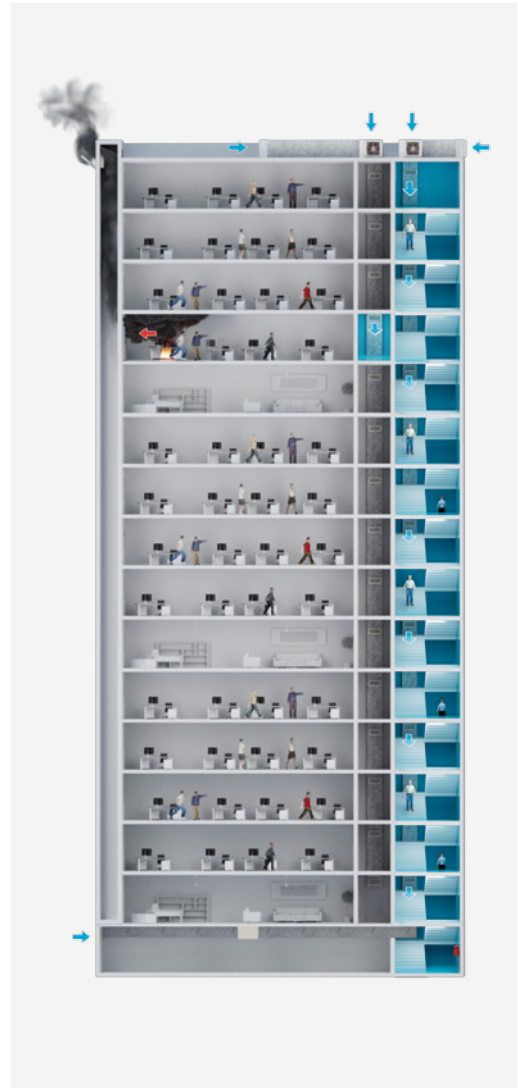

EDIFICIOS DE **GRAN ALTURA**

SOLUCIONES

FULL RANGE



HATCH PDS



KIT BOXPDS
KIT BOXPDS SMART



PDS LOBBY CONTROL

ADVANCED



KIT BOXSMART
KIT BOXSMART II

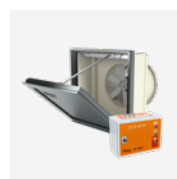

KIT BOXSMART FLAP



KIT BOXSMART EC

BASIC



KIT BOXPRES PLUS
KIT BOXPRES PLUS II



KIT SOBREPRESIÓN



PRESSKIT



TÚNELES

El sistema de ventilación para túneles, es indispensable que sea fiable para proporcionar seguridad al usuario a lo largo de los años.

La ventilación del túnel puede ser natural o forzada y en este último caso, es necesario la instalación de ventiladores para generar el movimiento del aire adecuado para mantener las condiciones de seguridad, tanto en modo confort como en caso de emergencia.

FUNCIONES DE LA VENTILACIÓN PARA TÚNELES

Sistema de ventilación en **modo emergencia** (en caso de incendio):



Ofrece seguridad.



Evacuación de humo y calor en caso de incendio.



Permite mantener libres y seguras las vías de evacuación de personas.



Sistema de control seguro y automatizado para activar las maniobras de emergencia.

Sistema de ventilación en **modo confort** (salubridad):



Mantiene condiciones de salubridad adecuadas como la temperatura o la humedad.



Aporta aire fresco y limpio desde el exterior.



Extracción de gases contaminantes.

SISTEMAS DE CONTROL DE HUMO EN TÚNELES

Los sistemas de ventilación **pueden configurarse en función de diferentes elementos clave**, como la tipología de túnel, longitud, pendiente o cantidad de tráfico:

VENTILACIÓN
LONGITUDINAL

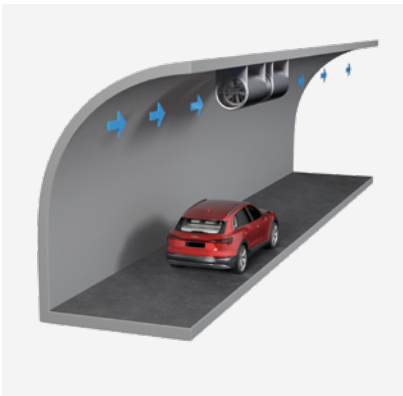

VENTILACIÓN
TRANSVERSAL

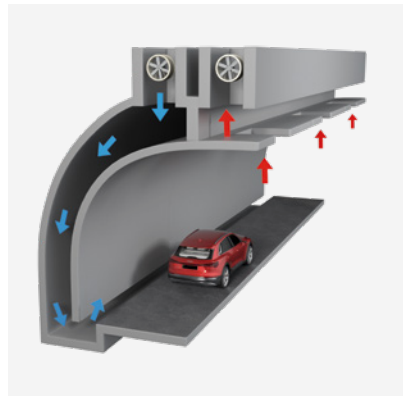

VENTILACIÓN
SEMITRANSVERSAL



SOLUCIONES



THT/IMP-TM



THT-TM



THT/IMP



CI



COMPUERTA



THT/WALL



THT/WALL-F

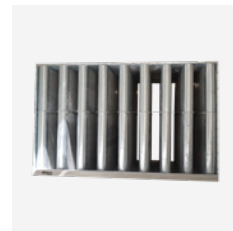

SILENCIADORES
RECTANGULARES



CONTROL
Y MANIOBRA

EXT. EVACUACIÓN HUMOS INMERSOS



27 THT
Extractores helicoidales
tubulares con carcasa corta
400 °C/2h y 300 °C/2h



77 THT/CL
Extractores helicoidales
tubulares con carcasa larga
400 °C/2h y 300 °C/2h, con
caja de bornes exterior



86 THT/WALL
Extractores dinámicos murales
con compuerta de apertura
motorizada, para la evacuación
de humo en caso de incendio,
400 °C/2h y 300 °C/2h



94 THT/WALL-F
Extractores dinámicos murales
con compuerta de apertura
motorizada, para la evacuación
de humo en caso de incendio,
400 °C/2h y 300 °C/2h



99 THT/HATCH
Exutorios dinámicos con
apertura motorizada equipados
con extractor de tejado, para
evacuación de humo en caso de
incendio 400 °C/2h y 300 °C/2h



107 CJTHT/PLUS
Unidades de extracción
helicoidales 400 °C/2h y
300 °C/2h con atenuador
acústico integrado



112 CJTHT
Ventiladores helicoidales
400 °C/2h y 300 °C/2h. Con
caja aislada acústicamente



119 CJTHT/ATEX
Unidades de extracción
helicoidales 400 °C/2h y
300 °C/2h, con certificación
ATEX



125 THT/IMP
Jet fans de gran alcance
400 °C/2h y 300 °C/2h,
unidireccionales o reversibles



131 TUNEL JET FAN
Jet fans especialmente
diseñados para ventilación de
túneles. Certificados 400 °C/2h
y 300 °C/2h según modelo



134 CI
Jet fans centrífugos de
inducción y de gran alcance
300 °C/2h y 400 °C/2h, para
trabajar dentro de la zona de
riesgo de incendio, con bajo
perfil



137 HTMF
Extractores de cubierta
multifuncional 400 °C/2h (F400)
y 300 °C/2h (F300)



145 THT/ROOF
Extractores helicoidales de
cubierta con salida de aire
vertical 400 °C/2h y 300 °C/2h



149 CJBBDT
Unidades de extracción con
motor directo, para trabajar
inmersos en zonas de riesgo de
incendio 400 °C/2h y 300 °C/2h



152 CBDT
Extractores centrífugos de
doble aspiración, motor directo,
para trabajar inmersos en zonas
de riesgo de incendio 400 °C/2h
y 300 °C/2h



155 CJV/EW
Unidades de extracción de
funcionamiento automático,
salida de aire vertical, motor EC
Technology y control de presión
constante para viviendas



158 TCR
Extractores centrífugos
400 °C/2h y 300 °C/2h, con
turbina a reacción



161 CJS
Unidades de extracción
400 °C/2h y 300 °C/2h, con
tapas intercambiables



164 CJMD
Unidades de extracción
400 °C/2h y 300 °C/2h, con
entrada y salida lineal



EXT. EVACUACIÓN HUMOS EXTERIORES



168 TCR/R
Extractores centrifugos 400 °C/2h, con turbina a reacción



172 TCR/R/EW
Extractores centrifugos 400 °C/2h, con turbina a reacción equipados con motor asincrónico de alta eficiencia IE3 regulable electrónicamente



177 CJTCR/R
Unidades de extracción 400 °C/2h, con turbina a reacción



182 CJTCR/R/EW
Unidades de extracción 400 °C/2h, con turbina a reacción equipados con motor asincrónico de alta eficiencia IE3 regulable electrónicamente



188 TCMP
Extractores centrifugos 400 °C/2h, con turbina a acción



193 CJMP
Unidades de extracción 400 °C/2h, con turbina a acción



199 CJTX-C
Unidades de extracción 400 °C/2h, a transmisión con ventilador de doble aspiración



209 CJSX
Unidades de extracción 400 °C/2h, a transmisión con ventilador de simple aspiración



216 CJSRX
Unidades de extracción 400 °C/2h para trabajar en el exterior de la zona de riesgo de incendios, accionados a transmisión con turbina a reacción



223 CJLINE
Unidades de extracción de aire y humo a 400 °C/2h, con entrada y salida lineal



227 CJLINE/EC
Unidades de extracción de aire con entrada y salida lineal, equipadas con motor EC Technology IE5



232 CKD
Unidades de extracción F400 con puerta de gran dimensión para poder realizar el mantenimiento con gran facilidad y aislamiento acústico de 40 mm



235 CKDR
Unidades de extracción F400 con puerta de gran dimensión para poder realizar el mantenimiento con gran facilidad y aislamiento acústico de 40 mm



239 CKDR/EC
Unidades de extracción con puerta de gran dimensión y aislamiento acústico de 40 mm, equipadas con motor EC Technology IE5



244 CHT
Extractores centrifugos de tejado 400 °C/2h, con salida de aire horizontal, sombrero en aluminio



248 CHT/EC
Extractores centrifugos de tejado 400 °C/2h, con salida de aire horizontal, con motor EC Technology IE5



252 CVT
Extractores centrifugos de tejado 400 °C/2h, con salida de aire vertical, sombrero en aluminio



256 CVT/EC
Extractores centrifugos de tejado con salida de aire vertical, con motor EC Technology IE5



SISTEMAS PRESURIZACIÓN FULL RANGE

260 KIT BOXPDS
Equipos de presurización para vías de evacuación, diseñados según la norma europea EN 12101-6



263 KIT BOXPDS SMART
Equipos de presurización para vías de evacuación con control avanzado, diseñados según la norma europea EN 12101-6



260 KIT BOXPDS II
Equipos de presurización para vías de evacuación con ventilador de reserva, diseñados según la norma europea EN 12101-6



263 KIT BOXPDS SMART II
Equipos de presurización para vías de evacuación con control avanzado y ventilador de reserva, diseñados según la norma europea EN 12101-6



266 HATCH PDS
Equipos de presurización de vías de evacuación en caso de incendio, diseñados según la norma europea EN 12101-6



SISTEMAS PRESURIZACIÓN ADVANCED

269 KIT BOXSMART
Sistema de presurización de escaleras o vías de evacuación. Mantiene una presión diferencial de 50 Pa en una sola etapa, diseñados según la norma europea EN 12101-6



269 KIT BOXSMART II
Sistema de presurización de escaleras o vías de evacuación. Mantiene una presión diferencial de 50 Pa en una sola etapa, diseñados según la norma europea EN 12101-6



274 KIT BOXSMART EC
Sistema de presurización de escaleras o vías de evacuación. Mantiene una presión diferencial de 50 Pa en una sola etapa, diseñados según la norma europea EN 12101-6



278 KIT BOXSMART FLAP
Sistema de presurización de escaleras o vías de evacuación. Mantiene una presión diferencial de 50 Pa en una sola etapa, diseñados según la norma europea EN 12101-6



271 BOXSMART
Cuadro de control para un ventilador



271 BOXSMART II
Cuadro de control con ventilador de reserva



276 BOXSMART EC
Cuadro de control para un ventilador motor EC



281 BOXSMART FLAP
Cuadro de control con ventilador de compuerta



SISTEMAS PRESURIZACIÓN BASIC

283 KIT SOBREPRESIÓN
Sistema de presurización de escaleras o vías de evacuación. Mantiene una presión diferencial de 50 Pa en una sola etapa, diseñados según la norma europea EN 12101-6



287 KIT BOXPRES PLUS
Sistema de presurización de escaleras o vías de evacuación. Mantiene una presión diferencial de 50 Pa en una sola etapa, diseñados según la norma europea EN 12101-6



289 PRESSKIT
Equipos de presurización de vestíbulos de conformidad con el DM 30/11/1983 y diseñados según la norma europea EN 12101-6



291 BOXPRES PLUS
Cuadro de control para un ventilador



291 BOXPRES PLUS II
Cuadro de control con ventilador de reserva



ACCESORIOS

- 294 BOXPARK**
Cuadros de control para sistemas de ventilación de aparcamientos con triple propósito: ventilación diaria, control de la concentración de CO y extracción de humo en caso de incendio



- 297 INT**
Interruptores de seguridad paro-marcha para cumplir la Norma UNE-EN 60204-1



- 297 INT/ATEX**
Interruptor ATEX paro-marcha según directivas 2014/34/UE y 2014/35/UE II 2D Ex tb IIIC T 85 °C Db II 3G Ex nR IIC T6 Gc IP66



- 297 IAT**
Interruptores de seguridad paro-marcha para 400 °C/2h para cumplir la Norma UNE-EN 60204-1



- 297 C2V**
Interruptor conmutador para motores de 2 velocidades



- 298 CABLE BOX**
Kit con cable eléctrico y caja de conexiones 400 °C/2h, para conexiones externas al motor, en instalaciones anti-incendios



- 298 RM**
Reguladores electrónicos de velocidad para motores monofásicos



- 299 VSD3/A-RFT - VSD1/A-RFM**
Variador electrónico de velocidad para motores AC



- 300 CENTRAL CO**
Centrales de detección de monóxido, para el control de la ventilación en aparcamientos



- 300 AET**
Cuadro eléctrico de arranque estrella/triángulo y protección de ventiladores trifásicos, con pulsadores de paro y marcha



- 301 P-400**
Persianas de sobrepresión, certificadas 400 °C/2h



- 301 RT**
Rejilla de protección para la aspiración o impulsión de ventiladores helicoidales tubulares

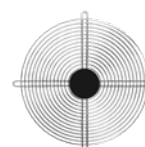

- 302 RPA**
Rejilla de protección para la aspiración de ventiladores centrífugos



- 302 R/THT**
Rejilla de protección para la aspiración de ventiladores helicoidales de la serie THT



- 303 BTB**
Brida de acoplamiento para ventiladores helicoidales



- 303 B**
Brida de acoplamiento para ventiladores centrífugos



- 304 BD**
Brida de acoplamiento doble para ventiladores centrífugos



- 305 BAC**
Brida de acoplamiento doble y elástica para ventiladores helicoidales



- 305 BIC**
Brida conversión de rectangular a circular para ventiladores centrífugos



- 306 PS**
Conjunto de pies soporte, para ventiladores tubulares



ACCESORIOS

306 MS
Marco soporte para facilitar el montaje en obra



307 PA
Placa de adaptación para montaje de accesorios, en extractores de tejado



307 BS
Base soporte elevada



307 BSS
Base soporte elevada con silenciador



308 PT
Obturadores de cierre automático para trabajo vertical. Versión 400 certificado 400 °C/2h



308 PT/H
Obturadores de cierre automático para trabajo horizontal. Versión 400 certificado 400 °C/2h



309 VIS
Viseras de impulsión con rejilla de protección

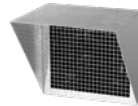

310 ACE ACE/400
Acoplamiento elástico para amortiguar vibraciones



311 TEJ
Tejadillos para intemperie



311 CM
Cubre motores para trabajos en intemperie

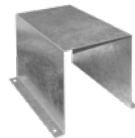

311 TAC
Tapa de acoplamiento circular



312 S
Silenciadores para acoplar a la aspiración o impulsión



316 SC
Silenciadores para acoplar a la aspiración o a la impulsión



316 SI-PIR
Detector de presencia



316 SI-TEMP+HUMEDAD
Sensor de temperatura y humedad relativa con display



317 SI-PRESIÓN
Transmisor de presión



317 SI-FUENTE DE ALIMENTACIÓN
Fuente de alimentación 24 V DC/AC



317 SI-VENT
Sensor de viento



317 SI-PRESOSTATO
Presostato



318 PDS LOBBY CONTROL
Cuadro de control y regulación automática independiente para sistemas de presurización de vestíbulos



ACCESORIOS

320 DAMPER BOX
Compuerta motorizada con detector óptico de humo incorporado para sistemas de presurización



320 DAMPER BOX SMART
Compuerta motorizada con detector óptico de humo incorporado para sistemas de presurización



321 SCDLS-MA
Compuertas de control de humo de compartimento único con accionamiento manual y automático



322 SCDRS-MA
Compuertas de control de humo circulares de compartimento único con accionamiento manual o automático



323 SCDLM-MA
Compuertas de control de humo multicompartimento con acción manual y automática



THT

Extractores helicoidales tubulares con carcasa corta 400 °C/2h y 300 °C/2h



Extractores helicoidales tubulares con carcasa corta para trabajar inmersos en zonas de riesgo de incendios.

Ventilador:

- Envolverte tubular en chapa de acero.
- Hélice de ángulo variable en fundición de aluminio.
- Homologación según norma EN 12101-3, con certificaciones n°: 0370-CPR-0305 (F400) y 0370-CPR-0973 (F300).
- Dirección aire motor-hélice.

Motor:

- Motores clase H para uso continuo S1 y uso emergencia S2. Con rodamientos a bolas, protección IP55 y 1 o 2 velocidades según modelo.
- Motores con eficiencia IE3 para potencias iguales o superiores a 0,75 kW, excepto monofásicos, 2 velocidades y 8 polos.
- Trifásico 230/400 V 50 Hz (hasta 3 kW) y 400/690 V 50 Hz (potencias superiores a 3 kW).

- Temperatura máxima del aire a transportar: Servicio S1 -20 °C +40 °C en continuo, apto también para climas cálidos con temperaturas hasta 50 °C. Servicio S2 300 °C/2h, 400 °C/2h.

Acabado:

- Anticorrosivo en resina de poliéster polimerizada a 190 °C, previo desengrase con tratamiento nanotecnológico libre de fosfatos.

Versiones disponibles:

- THT/CL: ventiladores helicoidales tubulares con carcasa larga equipada con trampilla de inspección.

Bajo demanda:

- Dirección aire hélice-motor.
- Hélices reversibles 100%.

Código de pedido

De tamaño 40 a tamaño 100

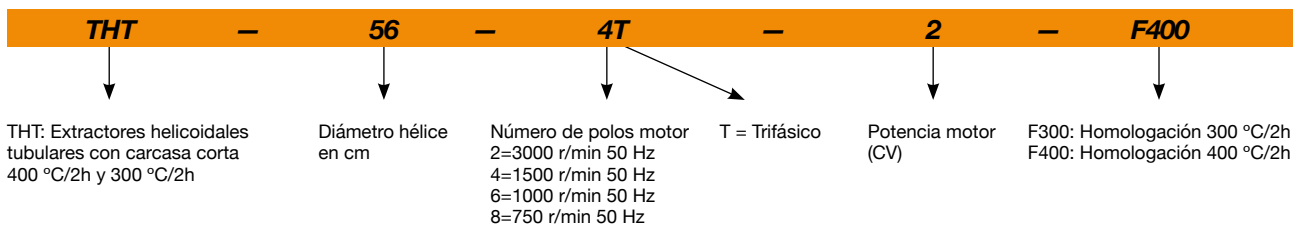

De tamaño 125 a tamaño 160

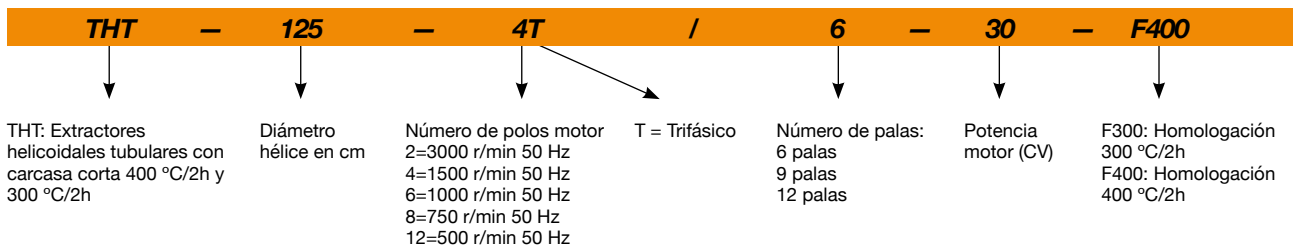

Características técnicas

Modelo ¹	Velocidad (r/min)	Intensidad máxima admisible (A)			Potencia instalada (kW)	Ángulo inclinación palas (°)	Caudal máximo (m ³ /h)	Nivel presión sonora ² dB (A) Aspiración	Peso aprox. (Kg)
		230V	400V	690V					
THT-40-2T-1.5 IE3	2880	4,02	2,23		1,10	20	7040	71	31
THT-40-2/4T-1.5	2900 / 1435		2,89 / 1,04		1,10 / 0,25	20	7040 / 3480	71 / 56	32
THT-40-4T-0.75	1420	2,84	1,64		0,55	32	4800	55	29
THT-40-6T-0.75	930	2,90	1,75		0,55	32	3150	46	34
THT-40-6/12T-0.75	940 / 455		1,98 / 0,84		0,55 / 0,09	32	3150 / 1520	46 / 31	38
THT-45-2T-2 IE3	2880	5,32	2,95		1,50	16	9400	71	34
THT-45-2/4T-2	2940 / 1460		4,33 / 1,36		1,50 / 0,37	16	9400 / 4670	71 / 56	34
THT-45-2T-3 IE3	2900	7,56	4,19		2,20	22	11330	71	36
THT-45-2T-4 IE3	2900	9,94	5,51		3,00	28	13075	72	46
THT-45-4T-0.75	1420	2,84	1,64		0,55	36	7450	58	30
THT-45-6T-0.75	930	2,90	1,75		0,55	30	4450	48	35
THT-45-6/12T-0.75	940 / 455		1,98 / 0,84		0,55 / 0,09	30	4450 / 2150	48 / 33	39
THT-50-2T-3 IE3	2870	7,56	4,19		2,20	12	11950	76	43
THT-50-4T-0.75	1420	2,84	1,64		0,55	22	8390	60	32
THT-50-6T-0.75	930	2,90	1,75		0,55	32	7000	52	36
THT-56-2T-5.5 IE3	2890		7,18	4,32	4,00	16	18800	78	60
THT-56-4T-1 IE3	1430	3,08	1,79		0,75	22	11250	63	40
THT-56-4T-1.5 IE3	1420	4,1	2,37		1,10	30	13600	63	40
THT-56-4/8T-1.5	1440 / 705		2,69 / 1,12		1,10 / 0,25	30	13600 / 6640	63 / 48	43
THT-56-4T-2 IE3	1425	5,89	3,38		1,50	36	15030	64	43
THT-56-6T-0.75	930	2,9	1,75		0,55	38	10140	54	39
THT-56-6/12T-0.75	940 / 455		2,35 / 1,15		0,60 / 0,15	38	10140 / 4890	54 / 39	43
THT-63-2T-12 IE3	2920		18,07	10,44	9,20	18	32300	83	143
THT-63-2T-20 IE3	2960		26,50	15,35	15,00	28	39950	82	170
THT-63-4T-1 IE3	1430	3,08	1,79		0,75	14	15190	67	43
THT-63-4T-1.5 IE3	1420	4,1	2,37		1,10	20	17800	66	45
THT-63-4/8T-1.5	1440 / 705		2,69 / 1,12		1,10 / 0,25	20	17800 / 8680	66 / 51	49
THT-63-4T-2 IE3	1425	5,89	3,38		1,50	24	19280	66	49
THT-63-4/8T-2	1415 / 715		3,40 / 1,65		1,50 / 0,30	24	19280 / 9740	66 / 52	60
THT-63-4T-3 IE3	1435	7,86	4,52		2,20	32	22150	68	54
THT-63-4/8T-3	1415 / 700		4,80 / 1,85		2,20 / 0,45	32	22150 / 10920	68 / 53	66
THT-63-4T-4 IE3	1430	11,01	6,33		3,00	38	24240	69	63
THT-63-4/8T-4	1420 / 710		6,45 / 2,28		3,00 / 0,60	38	24240 / 12070	69 / 54	77
THT-63-6T-0.75	930	2,9	1,75		0,55	28	13590	57	45
THT-63-6/12T-0.75	940 / 455		2,35 / 1,15		0,60 / 0,15	28	13590 / 6550	57 / 42	49
THT-63-6T-1 IE3	940	3,36	1,93		0,75	38	15890	58	48
THT-63-6/12T-1	935 / 455		3,75 / 2,76		0,80 / 0,20	38	15890 / 7700	58 / 43	55
THT-71-4T-1.5 IE3	1420	4,1	2,37		1,10	12	19480	71	52
THT-71-4/8T-1.5	1440 / 705		2,69 / 1,12		1,10 / 0,25	12	19480 / 9500	71 / 56	56
THT-71-4T-2 IE3	1425	5,89	3,38		1,50	14	20900	70	56
THT-71-4/8T-2	1415 / 715		3,40 / 1,65		1,50 / 0,30	14	20900 / 10560	70 / 56	67
THT-71-4T-3 IE3	1435	7,86	4,52		2,20	22	25100	70	61
THT-71-4/8T-3	1415 / 700		4,80 / 1,85		2,20 / 0,45	22	25100 / 12370	70 / 55	74
THT-71-4T-4 IE3	1430	11,01	6,33		3,00	28	27480	70	70
THT-71-4/8T-4	1420 / 710		6,45 / 2,28		3,00 / 0,60	28	27480 / 13680	70 / 55	83
THT-71-6T-0.75	930	2,9	1,75		0,55	20	16100	60	52
THT-71-6/12T-0.75	940 / 455		2,35 / 1,15		0,60 / 0,15	20	16100 / 7760	60 / 45	56
THT-71-6T-1 IE3	940	3,36	1,93		0,75	26	17300	60	55
THT-71-6/12T-1	935 / 455		3,75 / 2,76		0,80 / 0,20	26	17300 / 8380	60 / 45	62
THT-71-6T-1.5 IE3	945	4,73	2,72		1,10	34	19930	61	61
THT-71-6/12T-1.5	940 / 460		3,52 / 2,00		1,20 / 0,30	34	19930 / 9760	61 / 46	69
THT-80-4T-3 IE3	1435	7,86	4,52		2,20	12	25450	75	69
THT-80-4/8T-3	1415 / 700		4,80 / 1,85		2,20 / 0,45	12	25450 / 12550	75 / 60	82
THT-80-4T-4 IE3	1430	11,01	6,33		3,00	16	30250	74	78

Características técnicas

Modelo ¹	Velocidad (r/min)	Intensidad máxima admisible (A)			Potencia instalada (kW)	Ángulo inclinación palas (°)	Caudal máximo (m ³ /h)	Nivel presión sonora ² dB (A) Aspiración	Peso aprox. (Kg)
		230V	400V	690V					
THT-80-4/8T-4	1420 / 710		6,45 / 2,28		3,00 / 0,60	16	30250 / 15060	74 / 59	92
THT-80-4T-5.5 IE3	1440		7,95	4,61	4,00	18	32750	73	85
THT-80-4/8T-5.5	1450 / 715		7,88 / 2,87		3,80 / 1,00	18	32750 / 16150	73 / 58	118
THT-80-6T-1.5 IE3	945	4,73	2,72		1,10	18	21450	63	69
THT-80-6/12T-1.5	940 / 460		3,52 / 2,00		1,20 / 0,30	18	21450 / 10500	63 / 48	77
THT-80-6T-2 IE3	945	6,25	3,62		1,50	26	25950	64	78
THT-80-6/12T-2	960 / 470		4,46 / 3,43		1,60 / 0,40	26	25950 / 12700	64 / 49	82
THT-80-6T-3 IE3	950	9,78	5,62		2,20	32	29930	65	84
THT-80-6/12T-3	940 / 475		5,62 / 3,32		2,20 / 0,55	32	29930 / 15120	65 / 51	91
THT-80-8T-0.75	700	3,48	2,00		0,55	20	17540	57	62
THT-80-8T-1	710	5,06	2,92		0,75	28	20650	58	69
THT-90-4T-4 IE3	1430	11,01	6,33		3,00	8	33580	79	93
THT-90-4/8T-4	1420 / 710		6,45 / 2,28		3,00 / 0,60	8	33580 / 16720	79 / 64	106
THT-90-4T-5.5 IE3	1440		7,95	4,61	4,00	12	38890	78	99
THT-90-4/8T-5.5	1450 / 715		7,88 / 2,87		3,80 / 1,00	12	38890 / 19170	78 / 63	132
THT-90-4T-7.5 IE3	1430		10,40	6,04	5,50	18	46140	77	126
THT-90-4/8T-7.5	1455 / 725		11,40 / 3,86		5,50 / 1,10	18	46140 / 22910	77 / 62	140
THT-90-4T-10 IE3	1460		14,20	8,17	7,50	22	50140	76	137
THT-90-4/8T-10	1455 / 725		15,10 / 5,16		7,50 / 1,50	22	50140 / 24900	76 / 61	140
THT-90-6T-2 IE3	945	6,25	3,62		1,50	16	28780	66	92
THT-90-6/12T-2	960 / 470		4,46 / 3,43		1,60 / 0,40	16	28780 / 14090	66 / 51	96
THT-90-6T-3 IE3	950	9,78	5,62		2,20	24	34000	66	99
THT-90-6/12T-3	940 / 475		5,62 / 3,32		2,20 / 0,55	24	34000 / 17180	66 / 52	105
THT-90-6T-4 IE3	945	12,8	6,36		3,00	30	38900	69	124
THT-90-6/12T-4	970 / 485		7,37 / 3,53		2,80 / 0,70	30	38900 / 19450	69 / 54	126
THT-90-8T-1	710	5,06	2,92		0,75	18	22900	60	84
THT-90-8T-2	700	7,32	4,21		1,50	30	29490	63	99
THT-90-8T-3	705	9,3	5,35		2,20	32	30850	64	116
THT-100-4T-7.5 IE3	1430		10,40	6,04	5,50	10	46850	82	131
THT-100-4/8T-7.5	1455 / 725		11,40 / 3,86		5,50 / 1,10	10	46850 / 23260	82 / 67	145
THT-100-4T-10 IE3	1460		14,20	8,17	7,50	16	57400	79	142
THT-100-4/8T-10	1455 / 725		15,10 / 5,16		7,50 / 1,50	14	54700 / 27160	80 / 65	145
THT-100-4T-15 IE3	1455		20,70	11,99	11,00	22	66300	79	195
THT-100-4/8T-15	1470 / 730		20,70 / 7,19		11,00 / 3,00	22	66300 / 32880	79 / 64	195
THT-100-4T-20 IE3	1460		27,80	16,03	15,00	28	76150	80	210
THT-100-4/8T-20	1470 / 725		31,72 / 11,75		15,00 / 3,80	28	76150 / 37560	80 / 65	210
THT-100-4T/9-15 IE3	1460		20,70	11,99	11,00	18	55340	80	204
THT-100-4T/9-20 IE3	1460		27,80	16,03	15,00	22	63260	80	219
THT-100-4T/9-25 IE3	1475		35,40	20,39	18,50	26	70625	80	249
THT-100-4T/9-30 IE3	1475		42,20	24,44	22,00	30	74845	82	266
THT-100-6T-3 IE3	950	9,78	5,62		2,20	16	37600	70	105
THT-100-6/12T-3	940 / 475		5,62 / 3,32		2,20 / 0,55	16	37600 / 18990	70 / 56	112
THT-100-6T-4 IE3	945	12,8	6,36		3,00	20	41150	69	130
THT-100-6/12T-4	970 / 485		7,37 / 3,53		2,80 / 0,70	20	41150 / 20580	69 / 54	131
THT-100-6T-5.5 IE3	970		8,37	4,82	4,00	26	47780	70	142
THT-100-6T/9-5.5 IE3	970		11,00	6,35	4,00	20	39020	70	145
THT-100-6T/9-7.5 IE3	970		12,30	7,07	5,50	26	46765	71	153
THT-100-6T/9-10 IE3	970		15,20	8,83	7,50	34	52255	74	193
THT-125-4T/6-20 IE3	1460		27,80	16,03	15,00	10	78600	87	290
THT-125-4/8T/6-20	1470 / 725		31,72 / 11,75		15,00 / 3,80	10	78600 / 38770	87 / 72	290
THT-125-4T/6-25 IE3	1465		35,40	20,39	18,50	14	92550	86	343
THT-125-4/8T/6-27	1470 / 730		39,70 / 14,10		20,00 / 5,00	16	98830 / 48910	85 / 70	357
THT-125-4T/6-30 IE3	1470		42,20	24,44	22,00	16	98830	85	357
THT-125-4/8T/6-37	1475 / 735		54,55 / 18,50		28,00 / 6,50	20	110890 / 55260	85 / 70	437

Características técnicas

Modelo ¹	Velocidad (r/min)	Intensidad máxima admisible (A)			Potencia instalada (kW)	Ángulo inclinación palas (°)	Caudal máximo (m ³ /h)	Nivel presión sonora ² dB (A) Aspiración	Peso aprox. (Kg)
		230V	400V	690V					
THT-125-4T/6-40 IE3	1475		53,30	31,02	30,00	22	117450	85	437
THT-125-4T/6-50 IE3	1480		66,80	38,70	37,00	26	131050	85	473
THT-125-4T/6-60 IE3	1475		80,90	46,90	45,00	28	135820	85	543
THT-125-4T/6-75 IE3	1480		98,60	57,20	55,00	34	152100	88	643
THT-125-4T/9-25 IE3	1465		35,40	20,39	18,50	10	79650	87	352
THT-125-4T/9-30 IE3	1470		42,20	24,44	22,00	12	88290	86	366
THT-125-4/8T/9-27	1470 / 730		39,70 / 14,10		20,00 / 5,00	12	88290 / 43690	86 / 71	366
THT-125-4/8T/9-37	1475 / 735		54,55 / 18,50		28,00 / 6,50	16	104040 / 51840	85 / 70	446
THT-125-4T/9-40 IE3	1475		53,30	31,02	30,00	16	104040	85	446
THT-125-4T/9-50 IE3	1480		66,80	38,70	37,00	20	118400	85	482
THT-125-4T/9-60 IE3	1475		80,90	46,90	45,00	24	134970	85	534
THT-125-4T/9-75 IE3	1480		98,60	57,20	55,00	28	146770	86	634
THT-125-4T/9-100 IE3	1480		128,00	74,22	75,00	34	158560	88	773
THT-125-4T/12-50 IE3	1480		66,80	38,70	37,00	18	101660	86	516
THT-125-4T/12-60 IE3	1475		80,90	46,90	45,00	20	109180	86	561
THT-125-4T/12-75 IE3	1480		98,60	57,20	55,00	26	131240	86	661
THT-125-4T/12-100 IE3	1480		128,00	74,22	75,00	32	154100	88	791
THT-125-6T/6-5.5 IE3	970		8,37	4,82	4,00	10	51500	77	218
THT-125-6T/6-7.5 IE3	970		12,30	7,07	5,50	14	60640	75	225
THT-125-6/12T/6-7.5	970 / 480		14,50 / 5,17		5,50 / 1,00	14	60640 / 30010	75 / 60	239
THT-125-6T/6-10 IE3	960		15,20	8,83	7,50	20	72650	74	255
THT-125-6/12T/6-10	970 / 490		13,60 / 5,69		7,20 / 1,80	20	72650 / 36510	74 / 60	275
THT-125-6T/6-15 IE3	955		22,50	13,07	11,00	26	85850	74	285
THT-125-6/12T/6-15	970 / 485		23,10 / 8,41		11,00 / 3,00	26	85850 / 42710	74 / 59	290
THT-125-6T/6-20 IE3	950		29,00	16,78	15,00	30	92850	76	343
THT-125-6/12T/6-24	970 / 480		41,60 / 13,21		17,60 / 2,85	34	99650 / 49320	78 / 63	437
THT-125-6T/9-10 IE3	960		15,20	8,83	7,50	14	63490	77	264
THT-125-6/12T/9-10	970 / 490		13,60 / 5,69		7,20 / 1,80	14	63490 / 31910	77 / 63	284
THT-125-6T/9-15 IE3	955		22,50	13,07	11,00	20	77550	75	294
THT-125-6/12T/9-15	970 / 485		23,10 / 8,41		11,00 / 3,00	20	77550 / 38580	75 / 60	299
THT-125-6T/9-20 IE3	950		29,00	16,78	15,00	26	92950	75	352
THT-125-6/12T/9-24	970 / 480		41,60 / 13,21		17,60 / 2,85	30	98500 / 48750	76 / 61	446
THT-125-6T/9-25 IE3	975		36,10	20,77	18,50	32	101450	77	372
THT-125-6T/9-30 IE3	975		42,30	24,35	22,00	36	106525	80	382
THT-125-6T/12-10 IE3	970		15,20	8,83	7,50	12	49630	79	328
THT-125-6T/12-15 IE3	970		22,50	13,07	11,00	18	67315	77	338
THT-125-6T/12-20 IE3	970		29,00	16,78	15,00	24	81840	76	396
THT-125-6T/12-25 IE3	975		36,10	20,77	18,50	30	96765	77	406
THT-125-6T/12-30 IE3	975		42,30	24,35	22,00	32	102040	78	416
THT-125-6T/12-40 IE3	985		56,00	32,50	30,00	34	106355	79	571
THT-140-6T/6-7.5 IE3	970		12,30	7,07	5,50	8	62800	83	260
THT-140-6T/6-15 IE3	955		22,50	13,07	11,00	16	86640	78	327
THT-140-6T/6-20 IE3	950		29,00	16,78	15,00	22	102950	77	396
THT-140-6T/6-25 IE3	975		36,10	20,77	18,50	24	108750	77	448
THT-140-6T/6-30 IE3	975		42,30	24,35	22,00	28	119050	77	457
THT-140-6T/9-15 IE3	955		22,50	13,07	11,00	12	77400	82	336
THT-140-6T/9-20 IE3	950		29,00	16,78	15,00	16	91200	81	405
THT-140-6T/9-25 IE3	975		36,10	20,77	18,50	20	103800	80	458
THT-140-6T/9-30 IE3	975		42,30	24,35	22,00	22	111000	79	467
THT-140-6T/9-40 IE3	985		56,00	32,50	30,00	28	128800	79	611
THT-140-6T/9-50 IE3	980		67,20	39,00	37,00	32	135750	80	696
THT-140-6T/9-60 IE3	985		84,40	48,90	45,00	38	145610	82	931
THT-140-6T/12-30 IE3	975		42,30	24,35	22,00	20	101570	81	492
THT-140-6T/12-40 IE3	985		56,00	32,50	30,00	28	128800	80	647

Características técnicas

Modelo ¹	Velocidad (r/min)	Intensidad máxima admisible (A)			Potencia instalada (kW)	Ángulo inclinación palas (°)	Caudal máximo (m ³ /h)	Nivel presión sonora ² dB (A) Aspiración	Peso aprox. (Kg)
		230V	400V	690V					
THT-140-6T/12-50 IE3	985		67,20	39,00	37,00	32	143360	81	730
THT-140-6T/12-60 IE3	985		84,40	48,90	45,00	36	156705	82	940
THT-140-6T/12-75 IE3	985		103,00	59,70	55,00	38	162890	83	965
THT-160-6T/6-20 IE3	950		29,00	16,78	15,00	12	111990	85	463
THT-160-6T/6-25 IE3	975		36,10	20,77	18,50	14	121100	84	515
THT-160-6T/6-30 IE3	975		42,30	24,35	22,00	16	129330	83	524
THT-160-6T/6-40 IE3	985		56,00	32,50	30,00	22	153700	82	669
THT-160-6T/6-50 IE3	980		67,20	39,00	37,00	26	170800	81	757
THT-160-6T/6-60 IE3	985		84,40	48,90	45,00	30	185460	82	984
THT-160-6T/6-75 IE3	985		103,00	59,70	55,00	34	199030	83	1029
THT-160-6T/9-25 IE3	975		36,10	20,77	18,50	10	104250	90	525
THT-160-6T/9-30 IE3	975		42,30	24,35	22,00	14	126800	88	534
THT-160-6T/9-40 IE3	985		56,00	32,50	30,00	18	145500	86	679
THT-160-6T/9-50 IE3	980		67,20	39,00	37,00	20	154940	85	768
THT-160-6T/9-60 IE3	985		84,40	48,90	45,00	24	176750	85	968
THT-160-6T/9-75 IE3	985		103,00	59,70	55,00	28	192290	84	1013
THT-160-6T/12-60 IE3	985		84,40	48,90	45,00	20	151615	86	1002
THT-160-6T/12-75 IE3	985		103,00	59,70	55,00	26	182250	85	1047

1 Los modelos 40, 45, 50 i 56-2T sólo en versión F300.

2 Los valores de los niveles sonoros, son presiones en dB(A) medidos a 3 metros, en campo libre.



Erp. (Energy Related Products)

Información de la Directiva 2009/125/EC descargable desde la web de SODECA o programa de selección QuickFan.

Características acústicas

Espectro de potencia sonora Lw(A) en dB(A) por banda de frecuencia en Hz
Valores tomados a la aspiración con caudal máximo

	63	125	250	500	1000	2000	4000	8000		63	125	250	500	1000	2000	4000	8000
40-2-1.5	47	63	75	83	88	86	82	75	63-8-2 (2V)	39	51	60	66	66	66	60	52
40-4-1.5 (2V)	32	48	60	68	73	71	67	60	63-4-3	56	68	77	83	83	83	77	69
40-4-0.75	37	53	63	70	71	68	67	68	63-8-3 (2V)	41	53	62	68	68	68	62	54
40-6-0.75	28	44	54	61	62	59	58	59	63-4-4	57	69	78	84	84	84	78	70
40-12-0.75 (2V)	12	28	38	45	46	43	42	43	63-8-4 (2V)	42	54	63	69	69	69	63	55
45-2-2	47	60	74	86	87	86	82	74	63-6-0.75	48	58	68	72	73	71	64	56
45-4-2 (2V)	32	45	59	71	72	71	67	59	63-12-0.75 (2V)	32	42	52	56	57	55	48	40
45-2-3	47	64	74	81	88	86	83	75	63-6-1	49	59	69	73	74	72	65	57
45-2-4	52	69	78	84	88	88	83	75	63-12-1 (2V)	32	42	52	56	57	55	48	40
45-4-0.75	47	59	67	73	73	73	68	60	71-4-1.5	57	73	80	86	86	86	82	74
45-6-0.75	37	49	57	63	63	63	58	50	71-8-1.5 (2V)	41	57	64	70	70	70	66	58
45-12-0.75 (2V)	21	33	41	47	47	47	42	34	71-4-2	56	72	79	85	85	85	81	73
50-2-3	58	74	84	91	92	89	88	89	71-8-2 (2V)	41	57	64	70	70	70	66	58
50-4-0.75	49	61	69	75	75	75	70	62	71-4-3	56	72	79	85	85	85	81	73
50-6-0.75	41	53	61	67	67	67	62	54	71-8-3 (2V)	41	57	64	70	70	70	66	58
56-2-5.5	53	66	84	92	94	93	88	81	71-4-4	63	75	79	85	85	86	83	75
56-4-1	51	63	72	78	78	78	72	64	71-8-4 (2V)	48	60	64	70	70	71	68	60
56-4-1.5	51	63	72	78	78	78	72	64	71-6-0.75	46	53	73	76	76	71	63	55
56-8-1.5 (2V)	35	47	56	62	62	62	56	48	71-12-0.75 (2V)	30	37	57	60	60	55	47	39
56-4-2	52	64	73	79	79	79	73	65	71-6-1	46	64	73	76	76	71	64	55
56-6-0.75	45	55	65	69	70	68	61	53	71-12-1 (2V)	29	47	56	59	59	54	47	38
56-12-0.75 (2V)	29	39	49	53	54	52	45	37	71-6-1.5	47	65	74	77	77	72	65	56
63-2-12	64	81	91	97	98	97	95	97	71-12-1.5 (2V)	32	50	59	62	62	57	50	41
63-2-20	63	80	90	96	97	96	94	96	80-4-3	55	71	84	91	91	88	82	74
63-4-1	48	64	76	82	84	81	74	66	80-8-3 (2V)	40	56	69	76	76	73	67	59
63-4-1.5	47	63	75	81	83	80	73	65	80-4-4	54	70	83	90	90	87	81	73
63-8-1.5 (2V)	31	47	59	65	67	64	57	49	80-8-4 (2V)	39	55	68	75	75	72	66	58
63-4-2	54	66	75	81	81	81	75	67	80-4-5.5	53	69	82	89	89	86	80	72

Características acústicas

Espectro de potencia sonora Lw(A) en dB(A) por banda de frecuencia en Hz
Valores tomados a la aspiración con caudal máximo

	63	125	250	500	1000	2000	4000	8000		63	125	250	500	1000	2000	4000	8000
80-8-5.5 (2V)	38	54	67	74	74	71	65	57	125-4/9-50	65	79	92	100	102	99	94	86
80-6-1.5	53	68	75	78	79	76	70	62	125-4/9-60	73	86	95	99	101	100	96	89
80-12-1.5 (2V)	38	53	60	63	64	61	55	47	125-4/9-75	74	87	96	100	102	101	97	90
80-6-2	59	69	75	79	80	78	73	65	125-4/9-100	76	89	98	102	104	103	99	92
80-12-2 (2V)	43	53	59	63	64	62	57	49	125-4/12-50	66	80	93	101	103	100	95	87
80-6-3	60	70	76	80	81	79	74	66	125-4/12-60	66	80	93	101	103	100	95	87
80-12-3 (2V)	45	55	61	65	66	64	59	51	125-4/12-75	74	87	96	100	102	101	97	90
80-8-0.75	46	59	67	72	74	71	64	53	125-4/12-100	76	89	98	102	104	103	99	92
80-8-1	47	60	68	73	75	72	65	54	125-6/6-5.5	64	79	89	92	93	90	85	77
90-4-4	61	77	88	94	95	93	88	80	125-6/6-7.5	62	77	87	90	91	88	83	75
90-8-4 (2V)	46	62	73	79	80	78	73	65	125-12/6-7.5 (2V)	47	62	72	75	76	73	68	60
90-4-5.5	60	76	87	93	94	92	87	79	125-6/6-10	61	76	86	89	90	87	82	74
90-8-5.5 (2V)	45	61	72	78	79	77	72	64	125-12/6-10 (2V)	46	61	71	74	75	72	67	59
90-4-7.5	59	75	86	92	93	91	86	78	125-6/6-15	61	76	86	89	90	87	82	74
90-8-7.5 (2V)	44	60	71	77	78	76	71	63	125-12/6-15 (2V)	45	60	70	73	74	71	66	58
90-4-10	58	74	85	91	92	90	85	77	125-6/6-20	63	78	88	91	92	89	84	76
90-8-10 (2V)	43	59	70	76	77	75	70	62	125-6/6-24	65	80	90	93	94	91	86	78
90-6-2	52	67	78	82	82	78	71	63	125-12/6-24 (2V)	50	65	75	78	79	76	71	63
90-12-2 (2V)	36	51	62	66	66	62	55	47	125-6/9-10	61	76	87	93	94	88	84	77
90-6-3	52	67	78	82	82	78	71	63	125-12/9-10 (2V)	46	61	72	78	79	73	69	62
90-12-3 (2V)	37	52	63	67	67	63	56	48	125-6/9-15	59	74	85	91	92	86	82	75
90-6-4	60	70	80	85	85	82	76	68	125-12/9-15 (2V)	43	58	69	75	76	70	66	59
90-12-4 (2V)	45	55	65	70	70	67	61	53	125-6/9-20	59	74	85	91	92	86	82	75
90-8-1	42	63	70	75	78	74	67	56	125-6/9-24	60	75	86	92	93	87	83	76
90-8-2	51	66	73	78	81	77	70	59	125-12/9-24 (2V)	45	60	71	77	78	72	68	61
90-8-3	53	67	74	79	82	78	71	60	125-6/9-25	61	76	87	93	94	88	84	77
100-4-7.5	67	83	90	97	98	96	92	84	125-6/9-30	64	79	90	96	97	91	87	80
100-8-7.5 (2V)	52	68	75	82	83	81	77	69	125-6/12-10	63	78	89	95	96	90	86	79
100-4-10	65	81	88	95	96	94	90	82	125-6/12-15	61	76	87	93	94	88	84	77
100-8-10 (2V)	50	66	73	80	81	79	75	67	125-6/12-20	60	75	86	92	93	87	83	76
100-4-15	71	83	87	93	94	94	91	83	125-6/12-25	61	76	87	93	94	88	84	77
100-8-15 (2V)	56	68	72	78	79	79	76	68	125-6/12-30	62	77	88	94	95	89	85	78
100-4-20	72	84	88	94	95	95	92	84	125-6/12-40	63	78	89	95	96	90	86	79
100-8-20 (2V)	57	69	73	79	80	80	77	69	140-6/6-7.5	63	79	91	97	98	96	94	96
100-4/9-15	65	81	88	95	96	94	90	82	140-6/6-15	58	74	86	92	93	91	89	91
100-4/9-20	72	84	88	94	95	95	92	84	140-6/6-20	57	73	85	91	92	90	88	90
100-4/9-25	72	84	88	94	95	95	92	84	140-6/6-25	56	72	84	92	94	89	87	89
100-4/9-30	74	86	90	96	97	97	94	86	140-6/6-30	57	73	85	91	92	90	88	90
100-6-3	57	72	82	85	86	83	75	67	140-6/9-15	64	77	89	97	99	95	91	83
100-12-3 (2V)	42	57	67	70	71	68	60	52	140-6/9-20	63	76	88	96	98	94	90	82
100-6-4	56	71	81	84	85	82	74	66	140-6/9-25	62	75	87	95	97	93	89	81
100-12-4 (2V)	41	56	66	69	70	67	59	51	140-6/9-30	61	74	86	94	96	92	88	80
100-6-5.5	57	72	82	85	86	83	75	67	140-6/9-40	61	74	86	94	96	92	88	80
100-6/9-5.5	57	72	82	85	86	83	75	67	140-6/9-50	52	65	76	85	91	94	98	92
100-6/9-7.5	58	73	83	86	87	84	76	68	140-6/9-60	54	67	78	87	93	96	100	94
100-6/9-10	61	76	86	89	90	87	79	71	140-6/12-30	63	76	88	96	98	94	90	82
125-4/6-20	69	85	96	103	104	102	95	87	140-6/12-40	62	75	87	95	97	93	89	81
125-8/6-20 (2V)	54	70	81	88	89	87	80	72	140-6/12-50	53	66	77	86	92	95	99	93
125-4/6-25	68	84	95	102	103	101	94	86	140-6/12-60	54	67	78	87	93	96	100	94
125-4/6-27	67	83	94	101	102	100	93	85	140-6/12-75	55	68	79	88	94	97	101	95
125-8/6-27 (2V)	52	68	79	86	87	85	78	70	160-6/6-20	67	83	92	99	100	98	97	97
125-4/6-30	67	83	94	101	102	100	93	85	160-6/6-25	66	82	91	98	99	97	96	96
125-4/6-37	67	83	94	101	102	100	93	85	160-6/6-30	66	82	91	98	99	96	96	96
125-8/6-37 (2V)	52	68	79	86	87	85	78	70	160-6/6-40	64	80	89	96	97	95	94	94
125-4/6-40	67	83	94	101	102	100	93	85	160-6/6-50	64	80	89	96	97	94	94	94
125-4/6-50	67	83	94	101	102	100	93	85	160-6/6-60	64	80	89	96	97	95	94	94
125-4/6-60	67	83	94	101	102	100	93	85	160-6/6-75	56	69	78	86	92	97	100	100
125-4/6-75	70	86	97	104	105	103	96	88	160-6/9-25	75	88	97	105	107	105	100	91
125-4/9-25	67	81	94	102	104	101	96	88	160-6/9-30	73	86	95	103	105	103	98	89
125-4/9-30	66	80	93	101	103	100	95	87	160-6/9-40	71	84	93	101	103	101	96	87
125-4/9-27	51	65	78	86	88	85	80	72	160-6/9-50	70	83	92	100	102	100	95	86
125-8/9-27 (2V)	66	80	93	101	103	100	95	87	160-6/9-60	70	83	92	100	102	100	95	86
125-4/9-37	65	79	92	100	102	99	94	86	160-6/9-75	59	72	80	87	88	100	103	96
125-8/9-37 (2V)	50	64	77	85	87	84	79	71	160-6/12-60	71	84	93	101	103	101	96	87
125-4/9-40	65	79	92	100	102	99	94	86	160-6/12-75	60	73	81	88	89	101	104	97

Dimensiones mm

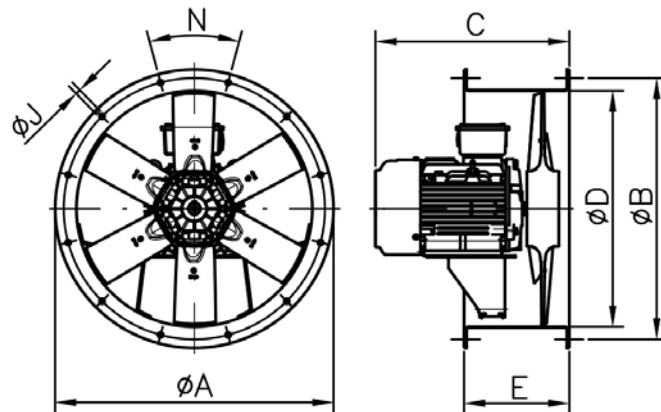

Tamaño motor	ØA	ØB	C	ØD	E	ØJ	N
THT-40 80	490	450	356	410	250	12	8x45°
THT-40 90S	490	450	398,5	410	250	12	8x45°
THT-40 90L	490	450	429	410	250	12	8x45°
THT-45 80	540	500	356	460	250	12	8x45°
THT-45 90S	540	500	398,5	460	250	12	8x45°
THT-45 90L	540	500	429	460	250	12	8x45°
THT-45 100	540	500	435	460	250	12	8x45°
THT-50 80	600	560	356	514	250	12	12x30°
THT-50 90S	600	560	398,5	514	250	12	12x30°
THT-50 90L	600	560	429	514	250	12	12x30°
THT-50 100	600	560	435	514	250	12	12x30°
THT-50 112	600	560	456,5	514	250	12	12x30°
THT-56 80	660	620	356	560	250	12	12x30°
THT-56 90S	660	620	398,5	560	250	12	12x30°
THT-56 90L	660	620	429	560	250	12	12x30°
THT-56 100	660	620	432	560	250	12	12x30°
THT-56 112	660	620	460,5	560	250	12	12x30°
THT-56 132S	660	620	495	560	250	12	12x30°
THT-56 132M	660	620	533	560	250	12	12x30°
THT-63 80	730	690	356	640	250	12	12x30°
THT-63 90S	730	690	398,5	640	250	12	12x30°
THT-63 90L	730	690	429	640	250	12	12x30°
THT-63 100	730	690	432	640	250	12	12x30°
THT-63 112	730	690	455,5	640	250	12	12x30°
THT-63 132S	730	690	523	640	250	12	12x30°
THT-63 132M	730	690	561	640	250	12	12x30°
THT-63 160M	730	690	660	640	350	12	12x30°
THT-63 160L	730	690	704	640	350	12	12x30°
THT-71 80	810	770	363	710	300	12	16x22°30'
THT-71 90S	810	770	398,5	710	300	12	16x22°30'
THT-71 90L	810	770	429	710	300	12	16x22°30'
THT-71 100	810	770	434	710	300	12	16x22°30'
THT-71 112	810	770	452,5	710	300	12	16x22°30'
THT-80 90L	900	860	426,5	800	300	12	16x22°30'
THT-80 100	900	860	462	800	300	12	16x22°30'
THT-80 112	900	860	480,5	800	300	12	16x22°30'
THT-80 132S	900	860	516	800	300	12	16x22°30'

Tamaño motor	ØA	ØB	C	ØD	E	ØJ	N
THT-90 100	1015	970	472	900	350	15	16x22°30'
THT-90 112	1015	970	500,5	900	350	15	16x22°30'
THT-90 132S	1015	970	526	900	350	15	16x22°30'
THT-90 132M	1015	970	564	900	350	15	16x22°30'
THT-100 112	1115	1070	490,5	1000	450	15	16x22°30'
THT-100 132S	1115	1070	526	1000	450	15	16x22°30'
THT-100 132M	1115	1070	564	1000	450	15	16x22°30'
THT-100 160M	1115	1070	658	1000	450	15	16x22°30'
THT-100 160L	1115	1070	702	1000	450	15	16x22°30'
THT-100 180M	1115	1070	711	1000	450	15	16x22°30'
THT-100 180L	1115	1070	749	1000	450	15	16x22°30'
THT-125 132M	1365	1320	603,5	1250	500	15	20x18°
THT-125 160M	1365	1320	660	1250	500	15	20x18°
THT-125 160L	1365	1320	704	1250	500	15	20x18°
THT-125 180M	1365	1320	715	1250	500	15	20x18°
THT-125 180L	1365	1320	753	1250	500	15	20x18°
THT-125 200	1365	1320	824,5	1250	500	15	20x18°
THT-125 225	1365	1320	881	1250	500	15	20x18°
THT-125 250	1365	1320	1025,5	1250	700	15	20x18°
THT-125 280	1365	1320	1129,6	1250	900	15	20x18°
THT-140 132S	1515	1470	537	1400	400	15	20x18°
THT-140 132M	1515	1470	575	1400	400	15	20x18°
THT-140 160L	1515	1470	704	1400	450	15	20x18°
THT-140 180L	1515	1470	762	1400	550	15	20x18°
THT-140 200	1515	1470	824,5	1400	550	15	20x18°
THT-140 225	1515	1470	881	1400	550	15	20x18°
THT-140 250	1515	1470	1025,5	1400	600	15	20x18°
THT-140 280	1515	1470	1110	1400	700	15	20x18°
THT-160 132S	1735	1680	537	1600	400	19	24x15°
THT-160 132M	1735	1680	575	1600	400	19	24x15°
THT-160 160L	1735	1680	704	1600	450	19	24x15°
THT-160 180L	1735	1680	762	1600	550	19	24x15°
THT-160 200	1735	1680	824,5	1600	550	19	24x15°
THT-160 225	1735	1680	881	1600	550	19	24x15°
THT-160 250	1735	1680	1025,5	1600	600	19	24x15°
THT-160 280	1735	1680	1110	1600	700	19	24x15°

Tamaños constructivos motores según potencia (1 velocidad)

	CV											
	0,75	1	1,5	2	3	4	5,5	7,5	10	12	15	20
2T (3000 r/min)	80	80	80	90S	90L	100LB	112M	132S	132S	132MA	160M	160M
4T (1500 r/min)	80	90S	90S	90L	100LA	100LB	112M	132S	132M	-	160ML	160L
6T (1000 r/min)	90S	90S	90L	100L	112M	132S	132MA	132MB	160M	-	160L	180ML
8T (750 r/min)	90L	100LA	100L	112M	132S	132M	160MA	160M	160L	-	180L	200MLA

	CV							
	22	25	30	40	50	60	75	100
2T (3000 r/min)	160L	180M	180L	200L	225S/M	225S/M	250S/M	280S/M
4T (1500 r/min)	-	180M	180L	200L	225S/M	225S/M	250S/M	280S/M
6T (1000 r/min)	-	200MLA	200MLB	225SMB	250S/M	280S/M	280S/M	-
8T (750 r/min)	-	225SMA	225SMB	250SMA	280S/M	280S/M	-	-

Tamaños constructivos motores según potencia (2 velocidades)

	CV											
	0,75	1	1,5	2	3	4	5,5	6	7,5	8	9	10
2/4 (3000/1500 r/min)	-	-	90S	90S	90L	100L	-	112M	-	-	132M	-
4/8 (1500/750 r/min)	-	-	90S	100L	100LA	100LC	132S	-	132S	132S	132ML	132M
6/12 (1000/500 r/min)	90L	100L	100LB	112M	112M	132MC	160M	160M	160LB	160LB	-	160LB

	CV									
	12	15	18	20	22	24	27	37	38	40
2/4 (3000/1500 r/min)	160MA	-	160M	-	160L	-	-	-	-	-
4/8 (1500/750 r/min)	-	160M	-	160L	180M	180M	180L	200MLA	200L	225S/M
6/12 (1000/500 r/min)	-	200MLC	160L	200M	-	250SMB	225S/M	-	225S/M	-

Accesorios



Configuración con BOXPARK



Cuadros de control para sistemas de ventilación de aparcamientos con triple propósito: ventilación diaria, control de la concentración de CO y extracción de humo en caso de incendio

Cuadros de control en envoltorio metálica con todos los elementos necesarios para la gestión y control de los ventiladores de sistemas de ventilación de aparcamientos, ya estén basados en redes de conductos o en ventiladores de impulsos, para el control de los niveles de concentración de CO y la extracción de humo en caso de incendio. Cuadros a medida para todas las potencias y número de ventiladores según necesidades del proyecto.

Más información ver serie BOXPARK.

Ejemplos de instalación con BOXPARK

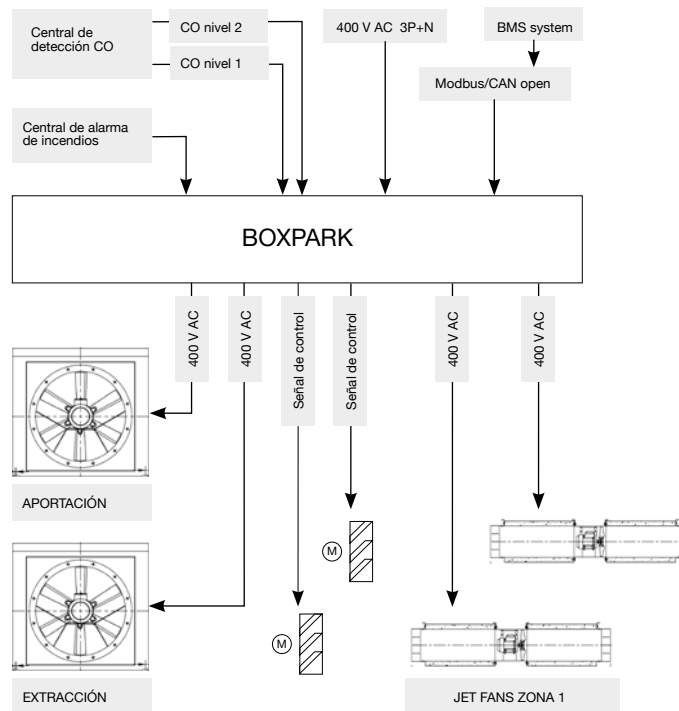

EJEMPLO SELECCIÓN

Curvas características

Q= Caudal en m³/h, m³/s y cfm

Pe= Presión estática en mmH₂O, Pa e inwg

Diámetro hélice en cm: 71

Número de polos motor: 6

Número de palas: 6

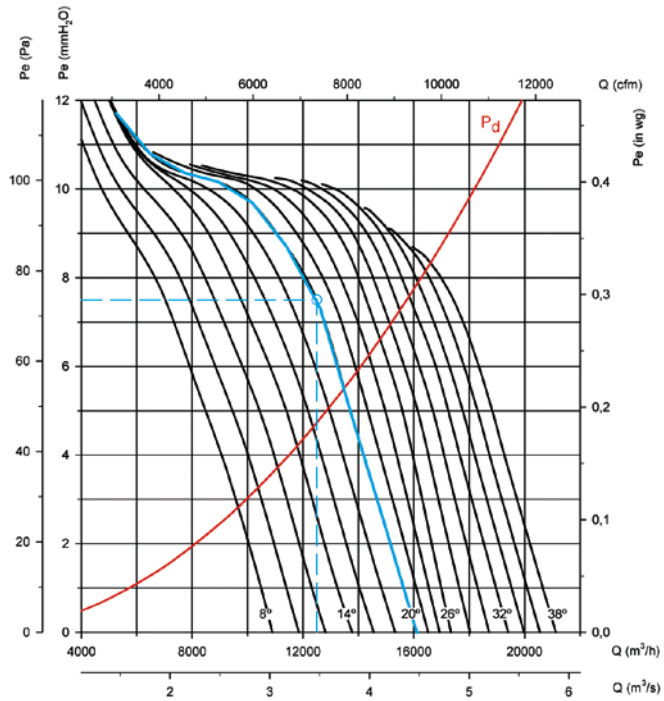

Datos de partida

Punto de trabajo:

- Caudal: 12.500 m³/h
- Pérdida de carga: 7,5 mmH₂O

Pasos para la selección del equipo

En la gráfica de presiones:

- Marcar el punto de trabajo, definido por el caudal de trabajo (12.500 m³/h) y la pérdida de carga (7,5 mmH₂O).
- Escoger la curva del equipo que más se acerque por encima al punto de trabajo. En nuestro caso se obtiene una curva de 20° de ángulo de pala.

En la gráfica de potencia:

- Marcar el punto de trabajo, definido por el caudal de trabajo (12.500 m³/h) y la curva de ángulo de pala escogido (20°).
- Leer la potencia absorbida en el eje de potencias a la izquierda. La Pa= 510 W en el punto de trabajo.
- Buscar recta roja que más se acerque al punto de trabajo por encima. En la parte derecha de la gráfica se obtiene el valor de potencia instalada de motor. En nuestro caso 0,55 kW o 0,75 CV.

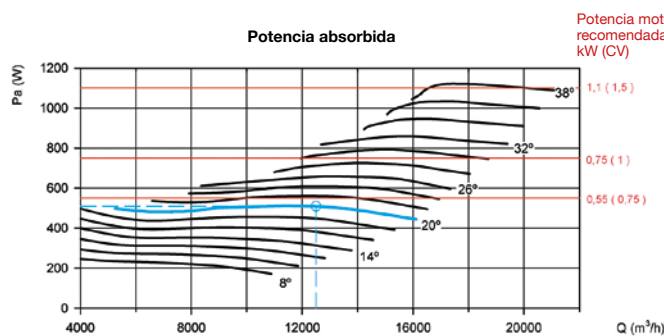

EJEMPLO CÓDIGO PEDIDO

THT	-	71	-	6T	-	0.75	-	F400
Nombre de serie: THT		Diámetro hélice en cm		Número de polos motor 2=3000 r/min 50 Hz 4=1500 r/min 50 Hz 6=1000 r/min 50 Hz 8=750 r/min 50 Hz 12=500 r/min 50 Hz	T = Trifásico	Potencia motor (CV)		F300: Homologación 300 °C/2h F400: Homologación 400 °C/2h

Curvas características

Q= Caudal en m³/h, m³/s y cfm

Pe= Presión estática en mmH₂O, Pa e inwg

Diámetro hélice en cm: 40

Número de polos motor: 2

Número de palas: 6

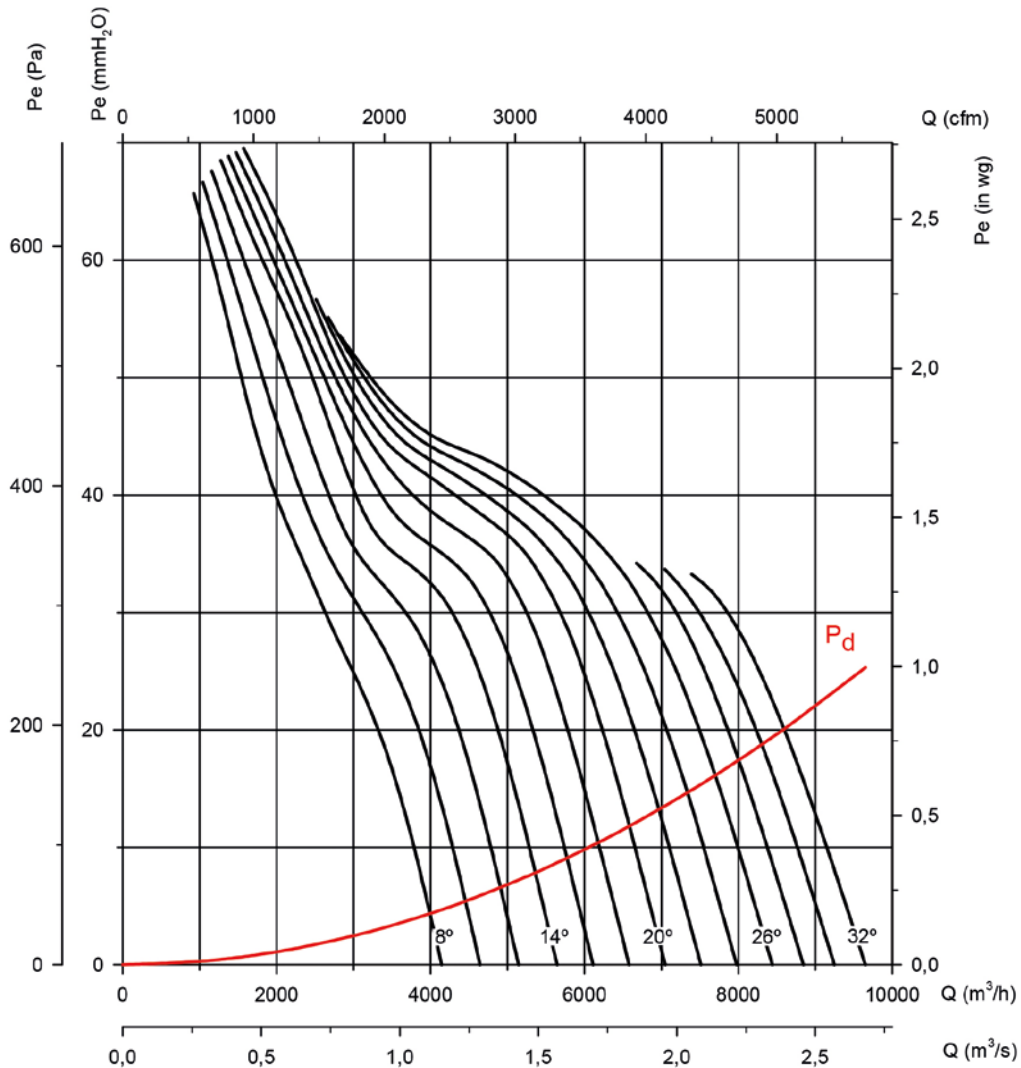

Potencia absorbida

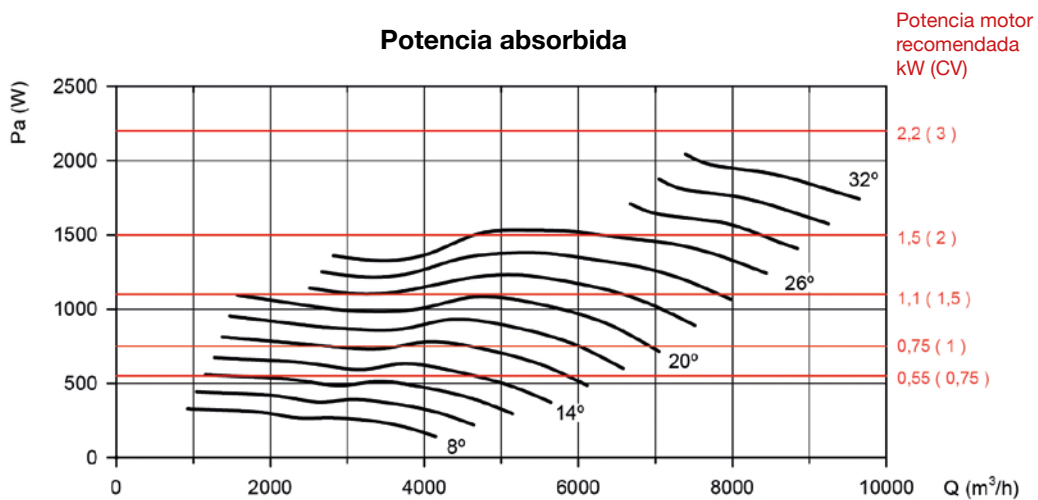

Curvas características

Q= Caudal en m³/h, m³/s y cfm

Pe= Presión estática en mmH₂O, Pa e inwg

Diámetro hélice en cm: 40

Número de polos motor: 4

Número de palas: 6

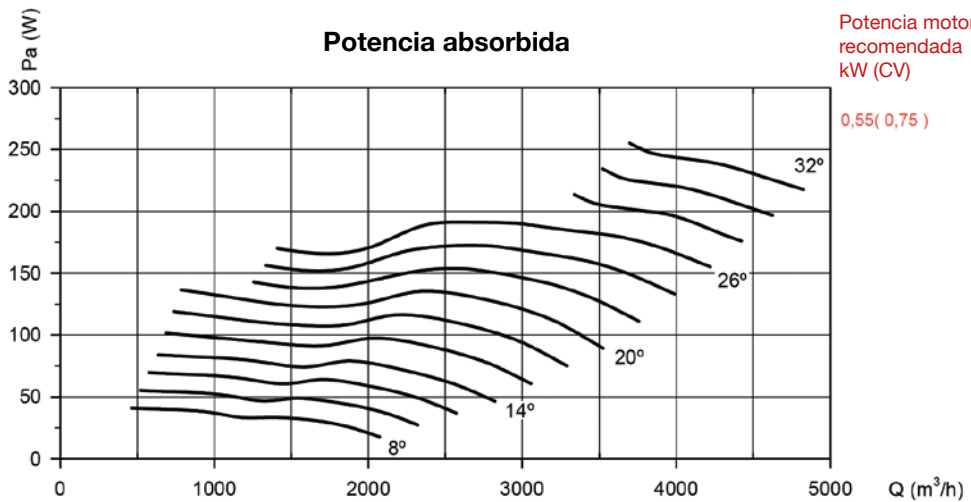
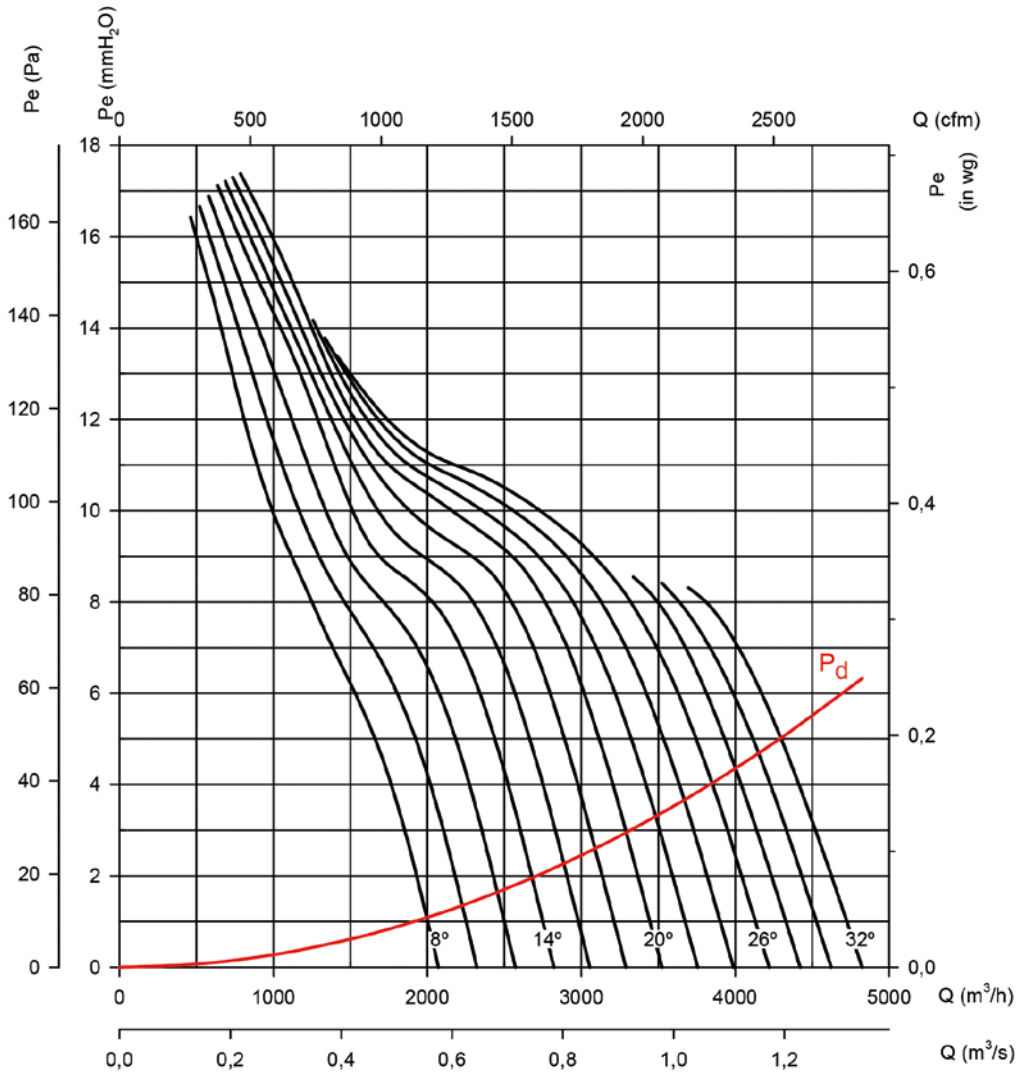

Curvas características

Q= Caudal en m³/h, m³/s y cfm

Pe= Presión estática en mmH₂O, Pa e inwg

Diámetro hélice en cm: 40

Número de polos motor: 6

Número de palas: 6

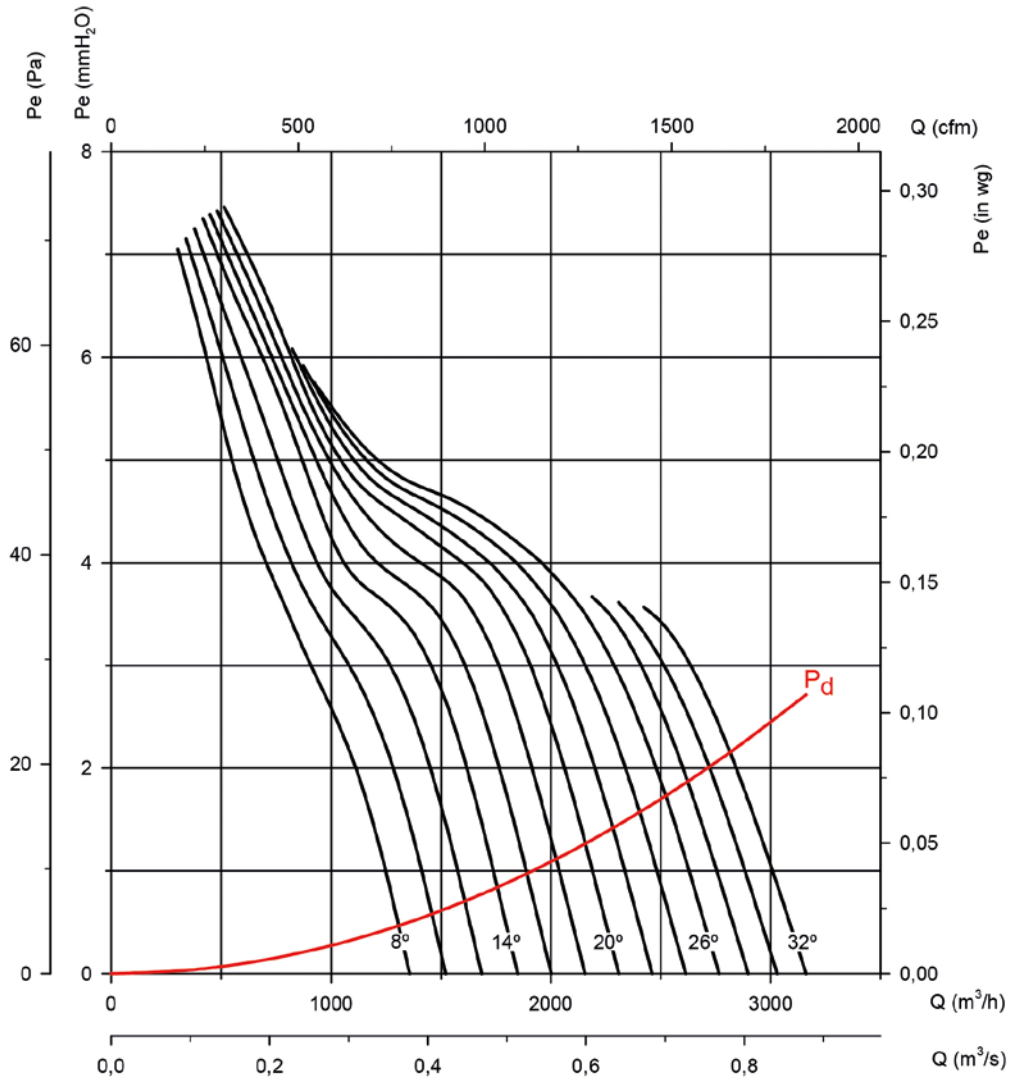

Potencia absorbida

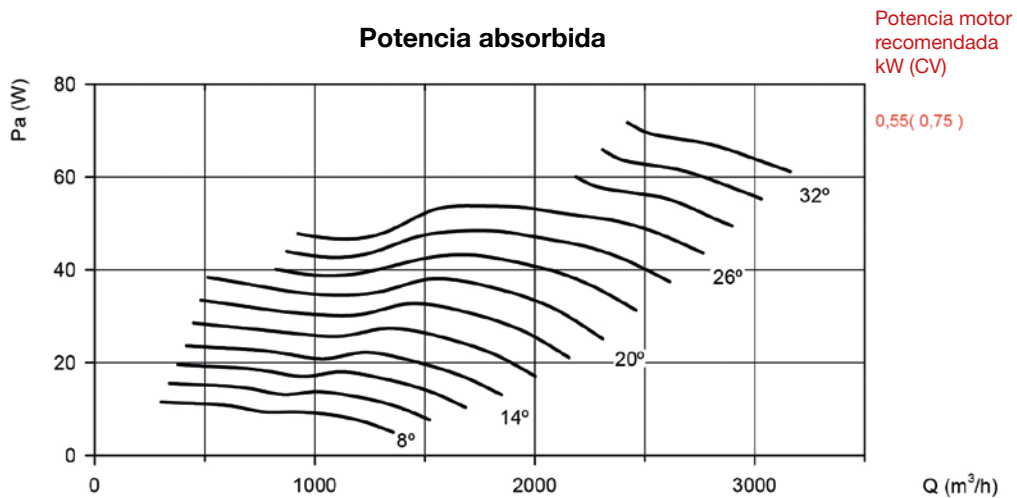

Curvas características

Q= Caudal en m³/h, m³/s y cfm

Pe= Presión estática en mmH₂O, Pa e inwg

Diámetro hélice en cm: 45

Número de polos motor: 2

Número de palas: 6

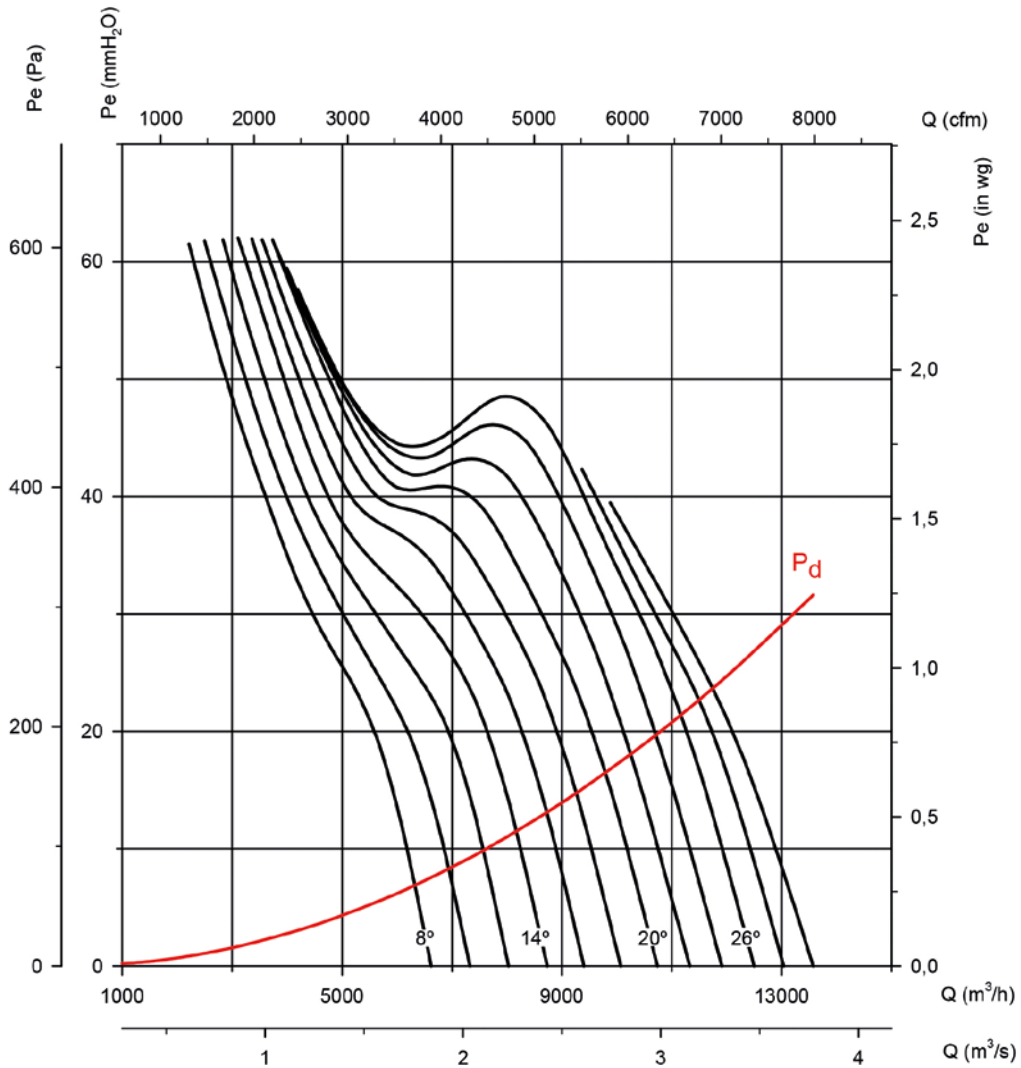

Potencia absorbida

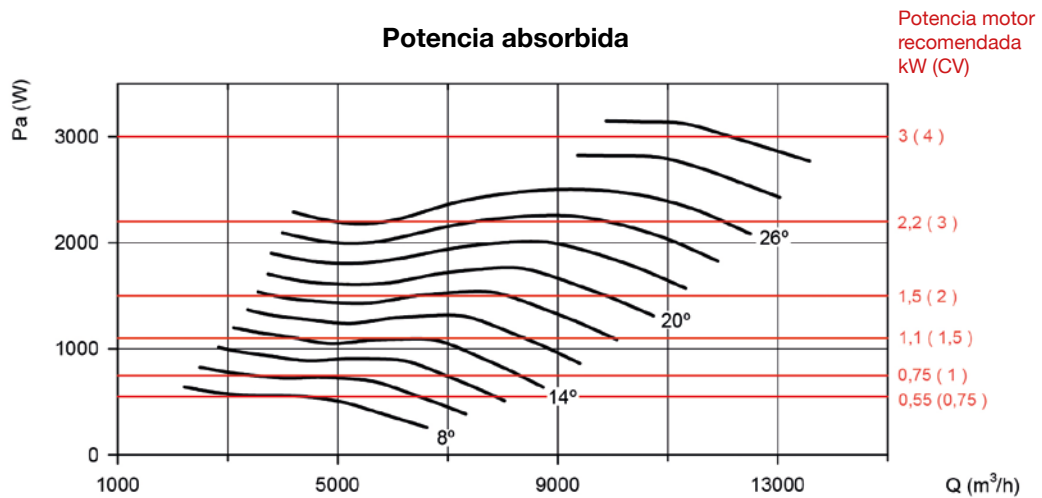

Curvas características

Q= Caudal en m³/h, m³/s y cfm

Pe= Presión estática en mmH₂O, Pa e inwg

Diámetro hélice en cm: 45

Número de polos motor: 4

Número de palas: 6

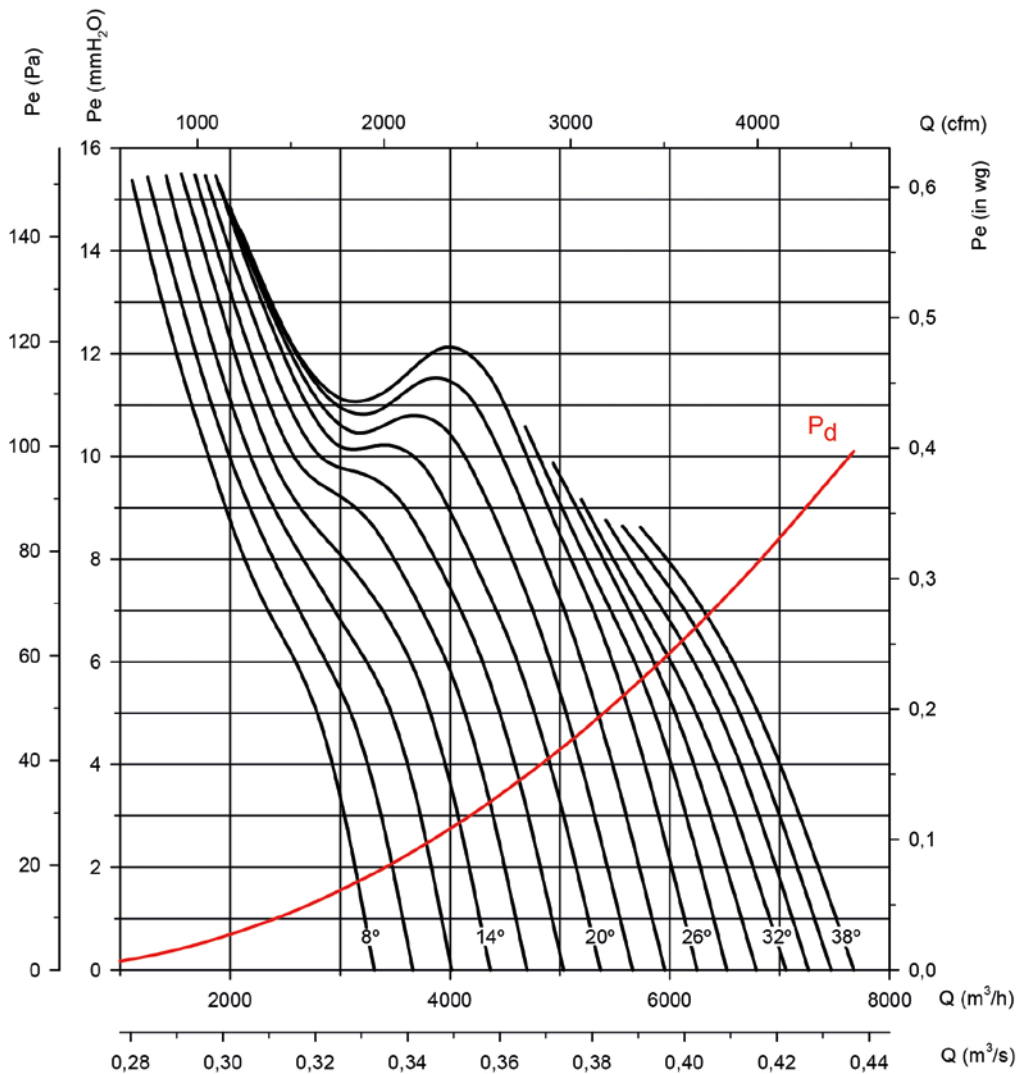

Potencia absorbida

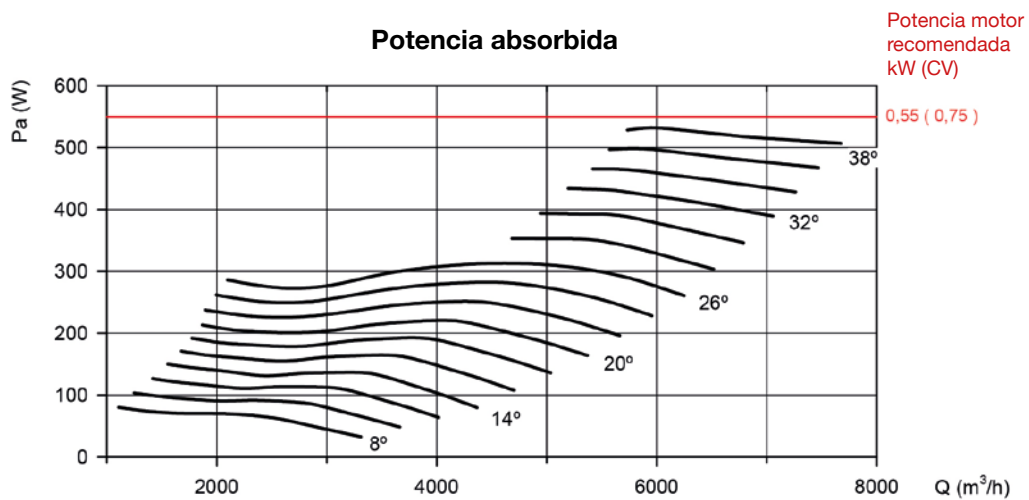

Curvas características

Q= Caudal en m³/h, m³/s y cfm

Pe= Presión estática en mmH₂O, Pa e inwg

Diámetro hélice en cm: 45

Número de polos motor: 6

Número de palas: 6

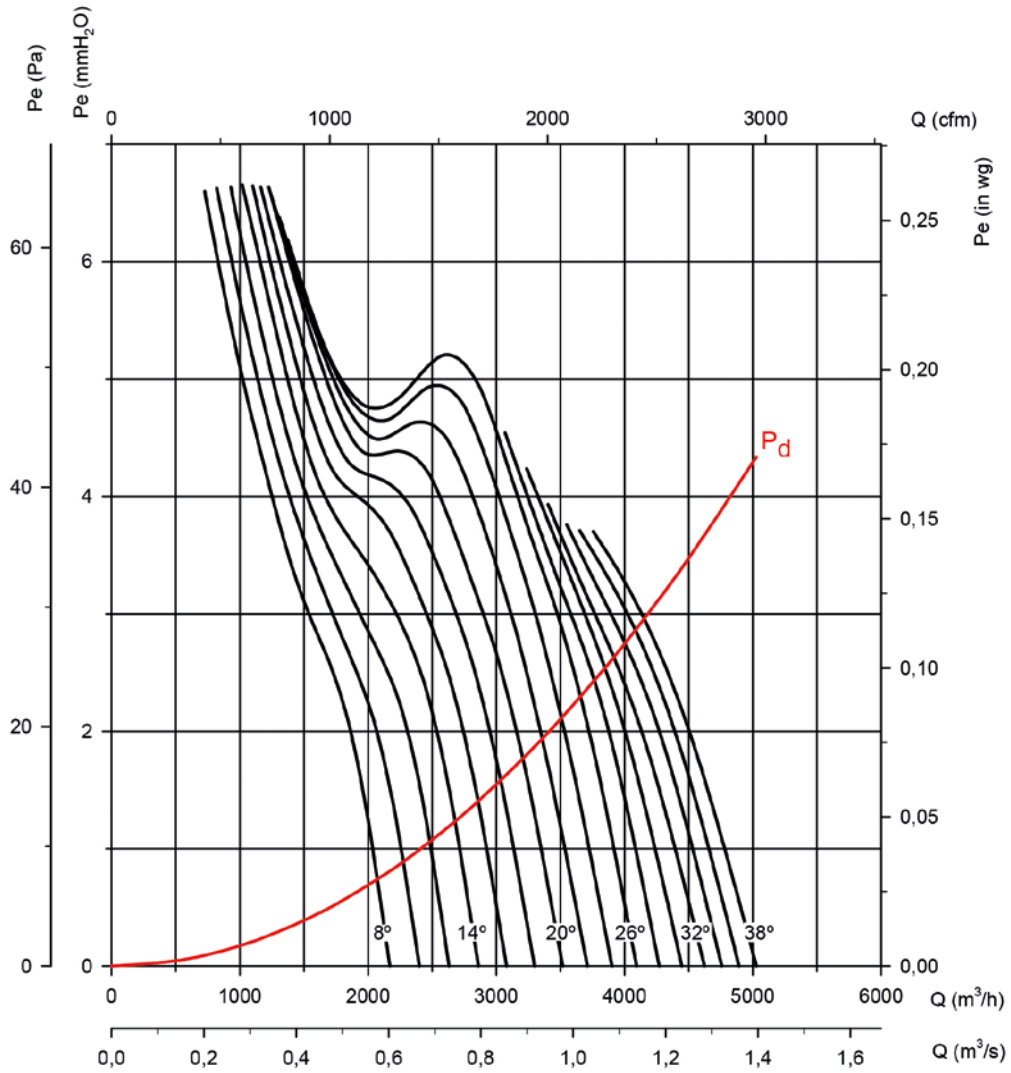

Potencia absorbida

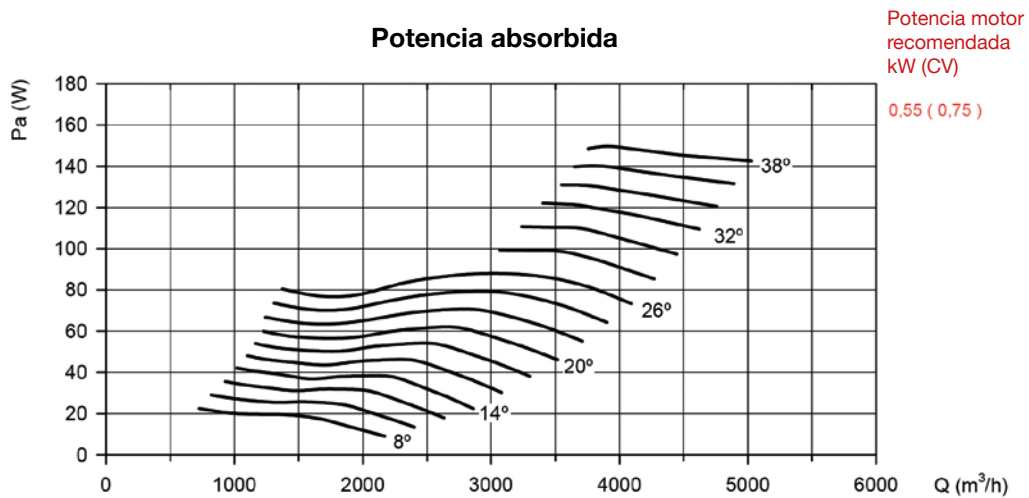

Curvas características

Q= Caudal en m³/h, m³/s y cfm

Pe= Presión estática en mmH₂O, Pa e inwg

Diámetro hélice en cm: 50

Número de polos motor: 2

Número de palas: 6

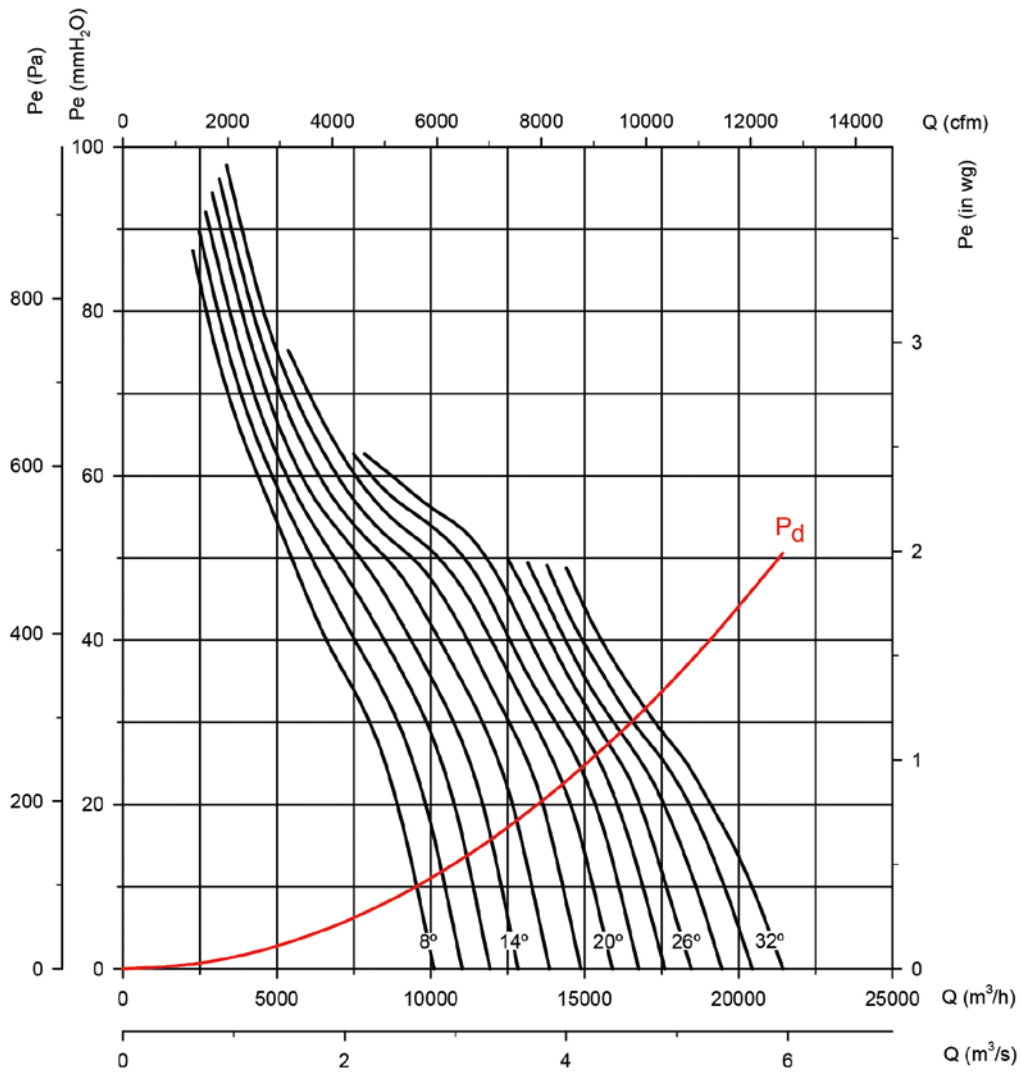

Potencia absorbida

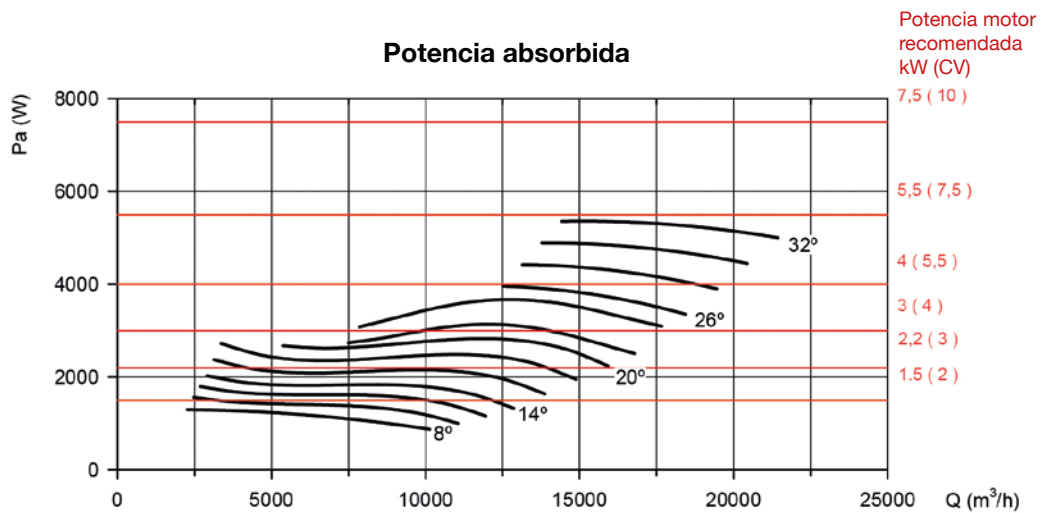

Curvas características

Q= Caudal en m³/h, m³/s y cfm

Pe= Presión estática en mmH₂O, Pa e inwg

Diámetro hélice en cm: 50

Número de polos motor: 4

Número de palas: 6

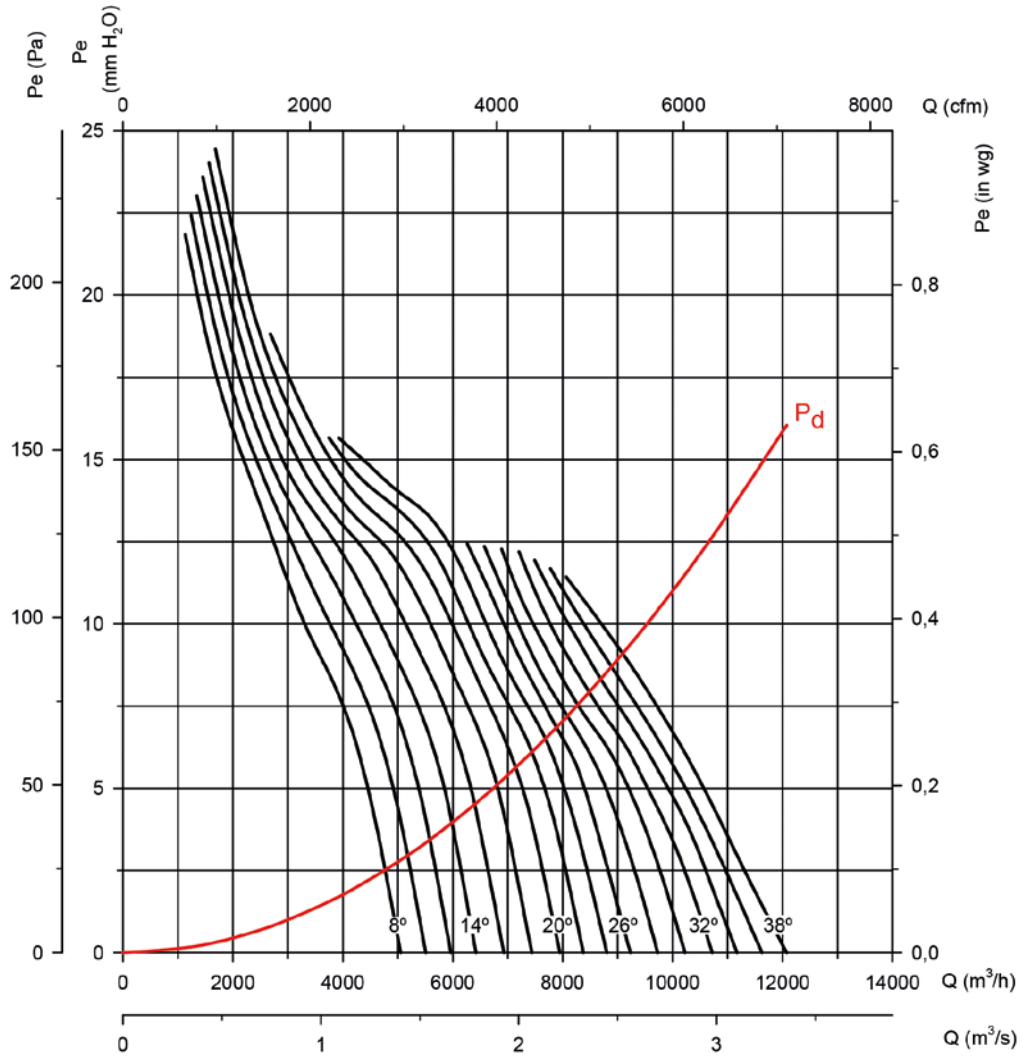

Potencia absorbida

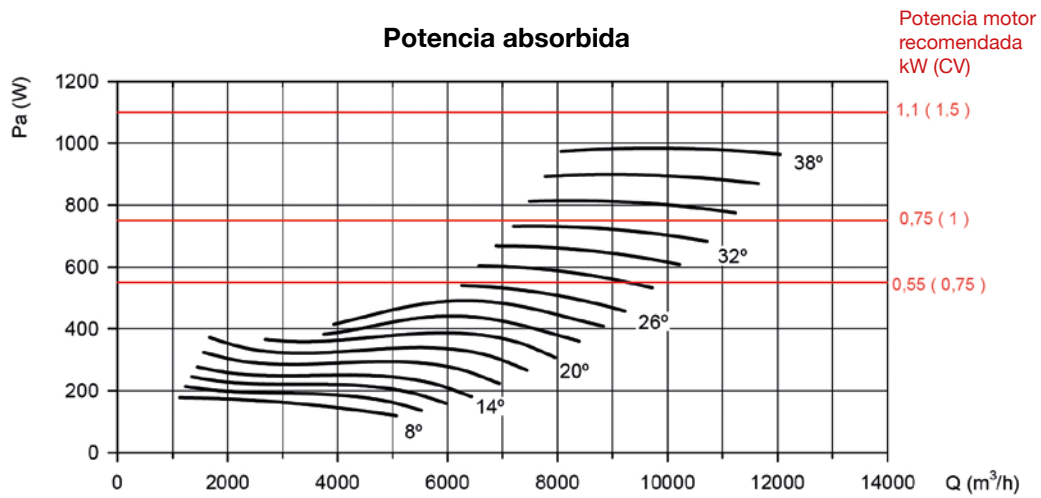

Curvas características

Q= Caudal en m³/h, m³/s y cfm

Pe= Presión estática en mmH₂O, Pa e inwg

Diámetro hélice en cm: 50

Número de polos motor: 6

Número de palas: 6

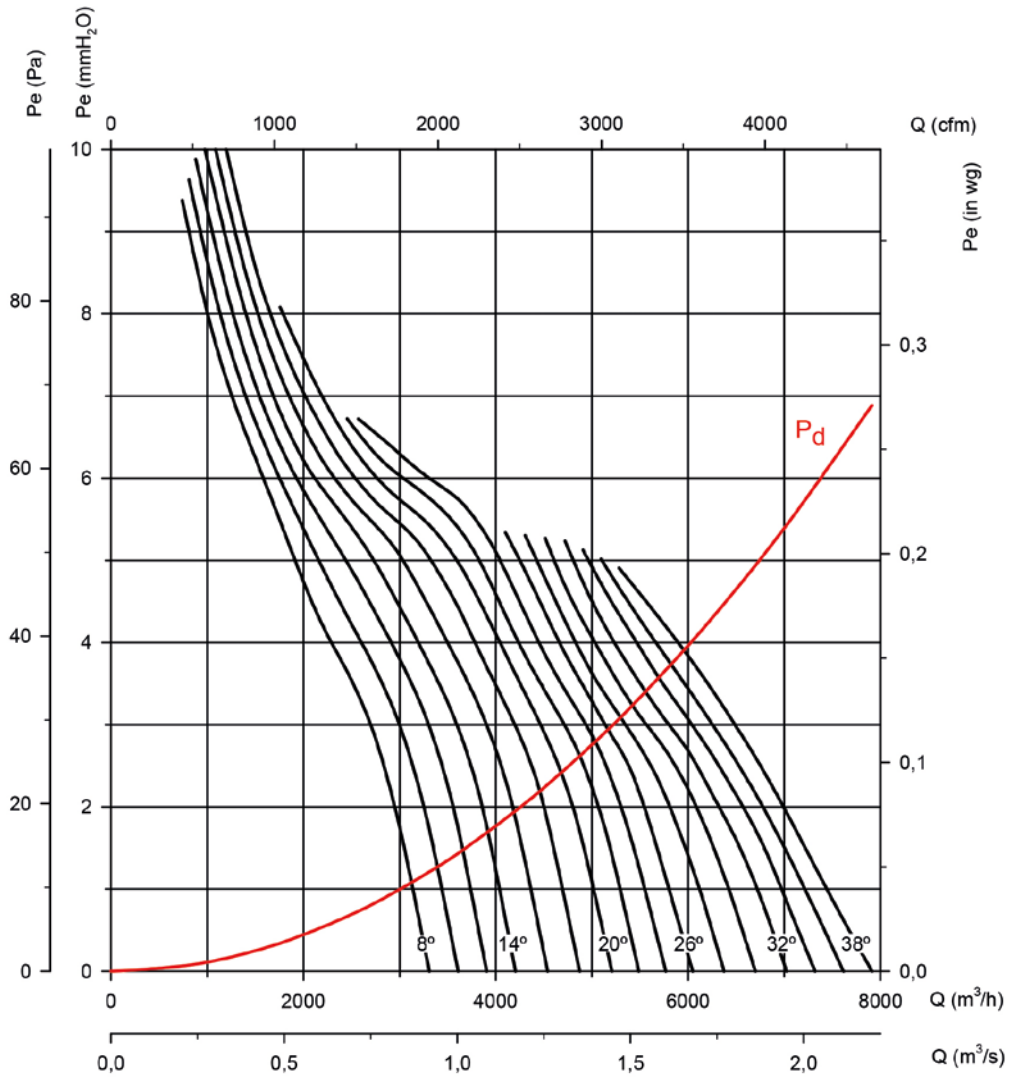

Potencia absorbida

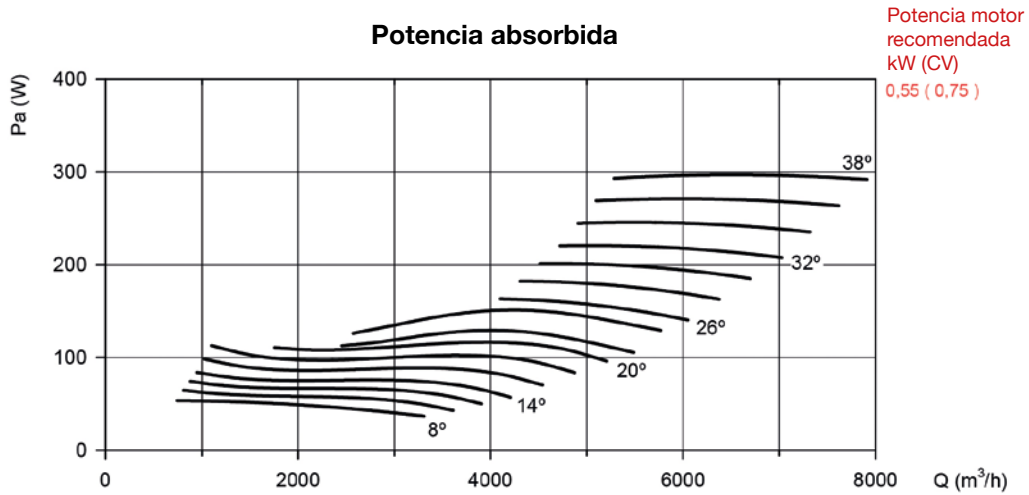

Curvas características

Q= Caudal en m³/h, m³/s y cfm

Pe= Presión estática en mmH₂O, Pa e inwg

Diámetro hélice en cm: 56

Número de polos motor: 2

Número de palas: 6

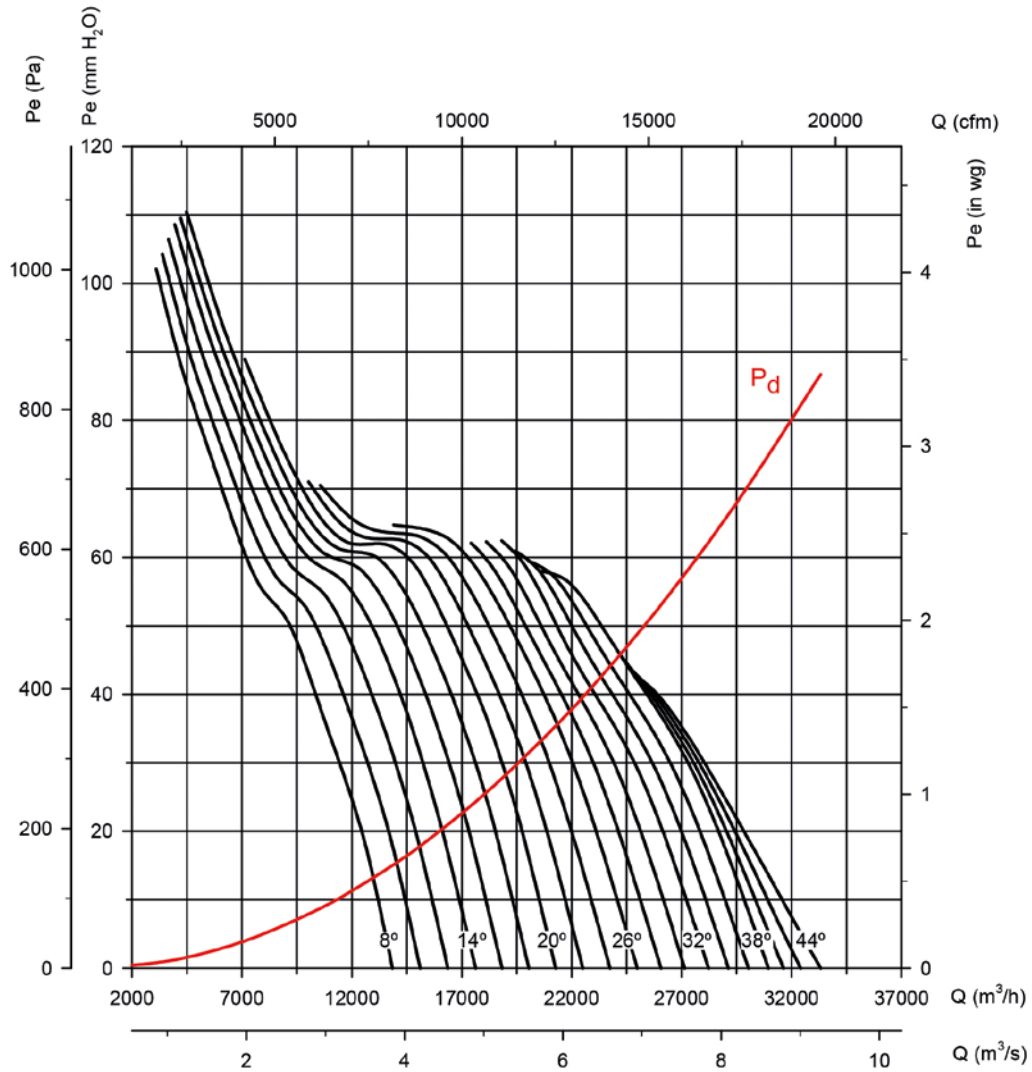

Potencia absorbida

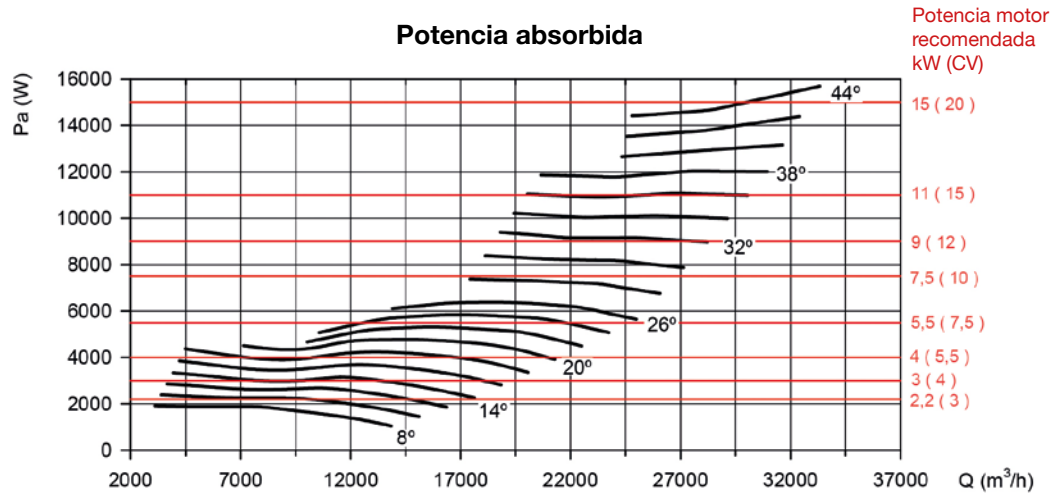

Curvas características

Q= Caudal en m³/h, m³/s y cfm

Pe= Presión estática en mmH₂O, Pa e inwg

Diámetro hélice en cm: 56

Número de polos motor: 4

Número de palas: 6

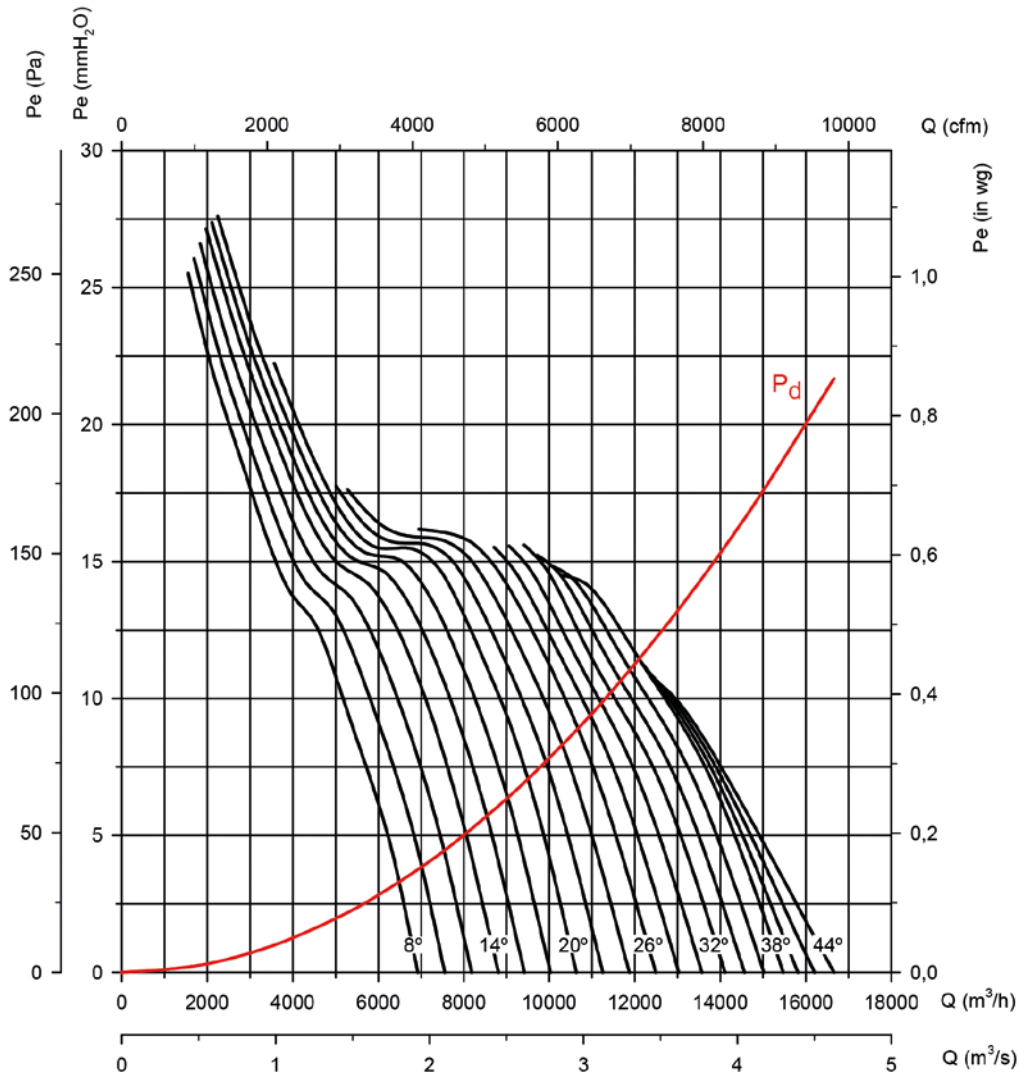

Potencia absorbida

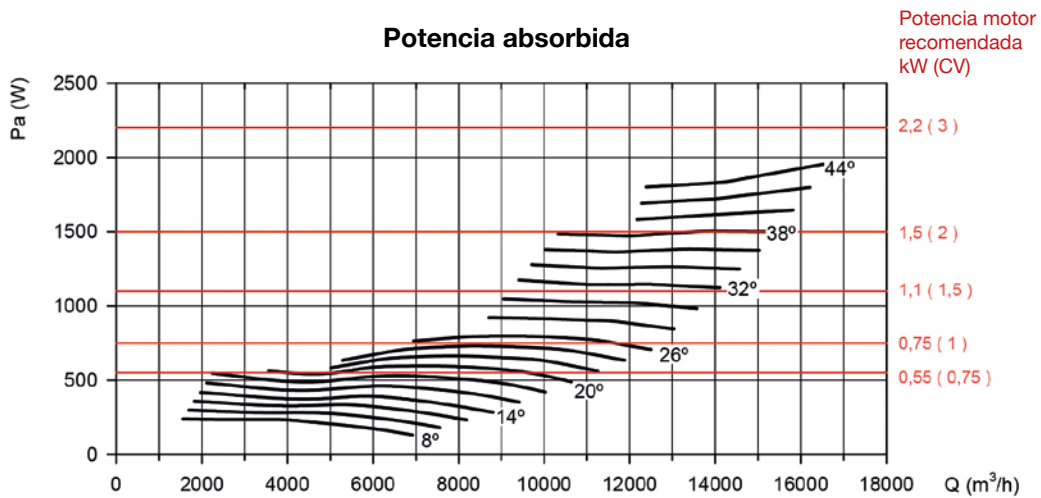

Curvas características

Q= Caudal en m³/h, m³/s y cfm

Pe= Presión estática en mmH₂O, Pa e inwg

Diámetro hélice en cm: 56

Número de polos motor: 6

Número de palas: 6

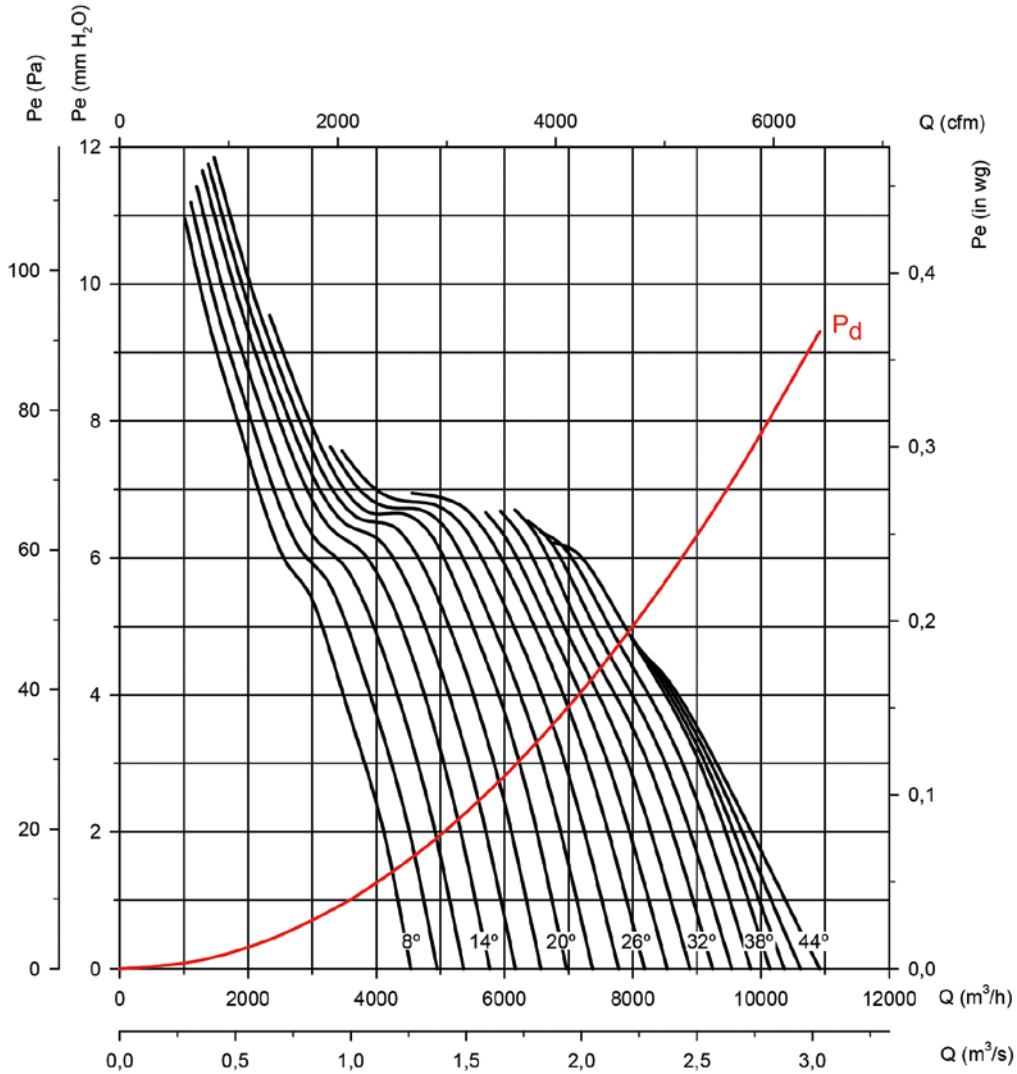

Potencia absorbida

Potencia motor
recomendada
kW (CV)

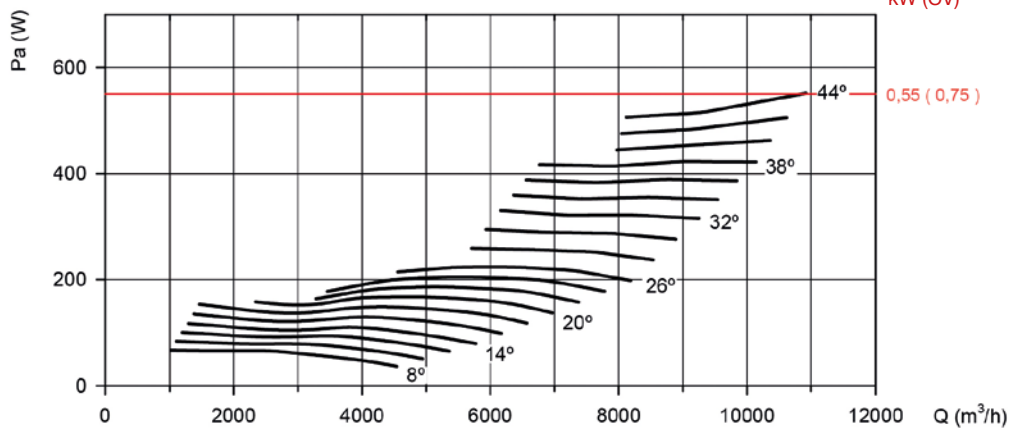

Curvas características

Q= Caudal en m³/h, m³/s y cfm

Pe= Presión estática en mmH₂O, Pa e inwg

Diámetro hélice en cm: 63

Número de polos motor: 2

Número de palas: 6

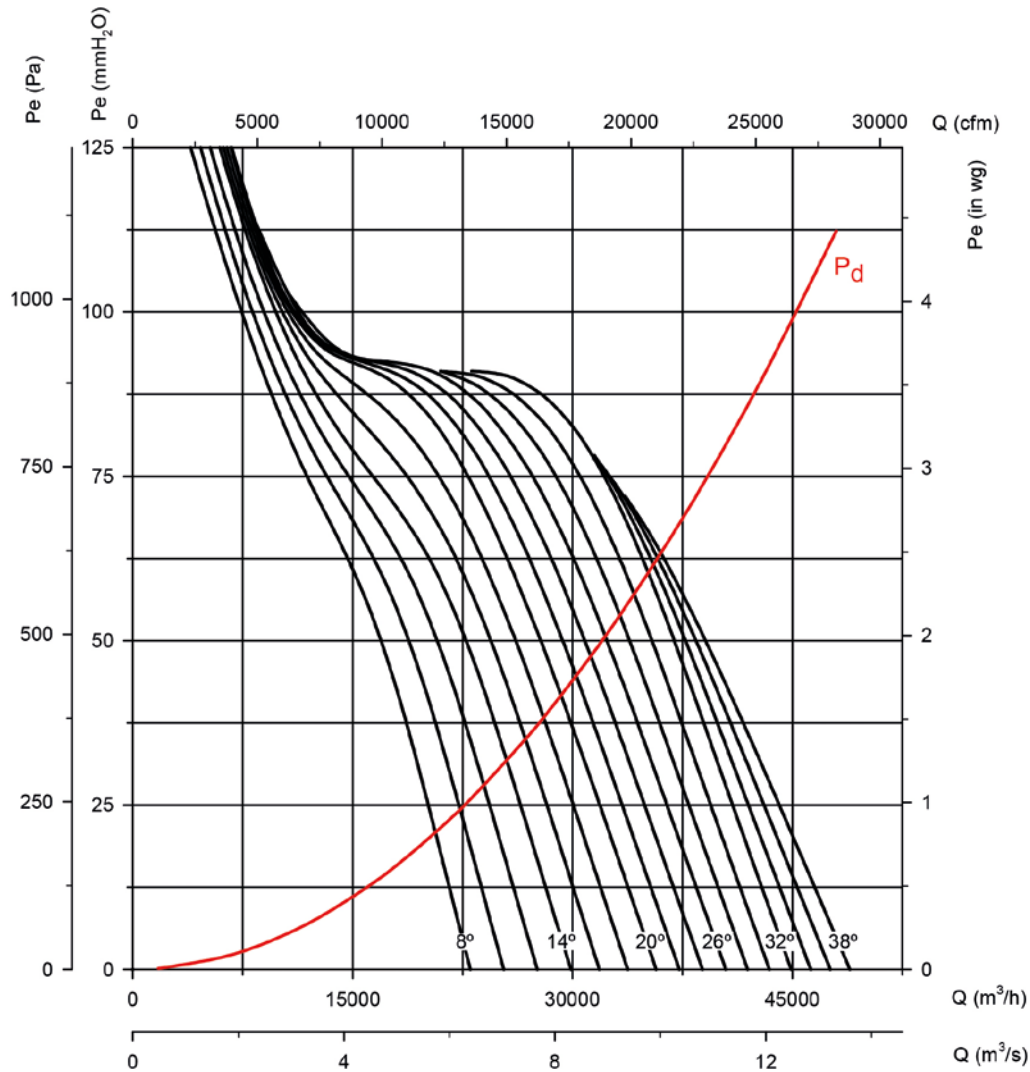

Potencia absorbida

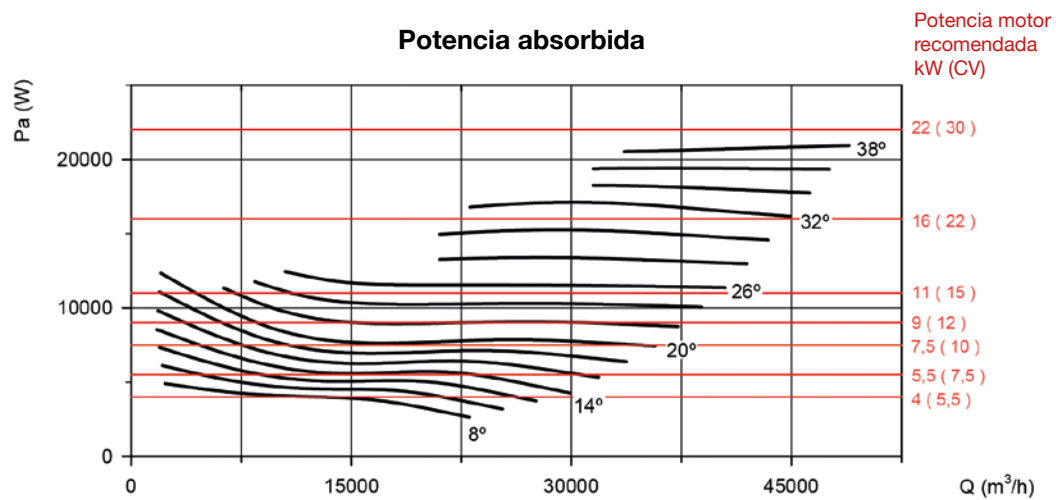

Curvas características

Q= Caudal en m³/h, m³/s y cfm

Pe= Presión estática en mmH₂O, Pa e inwg

Diámetro hélice en cm: 63

Número de polos motor: 4

Número de palas: 6

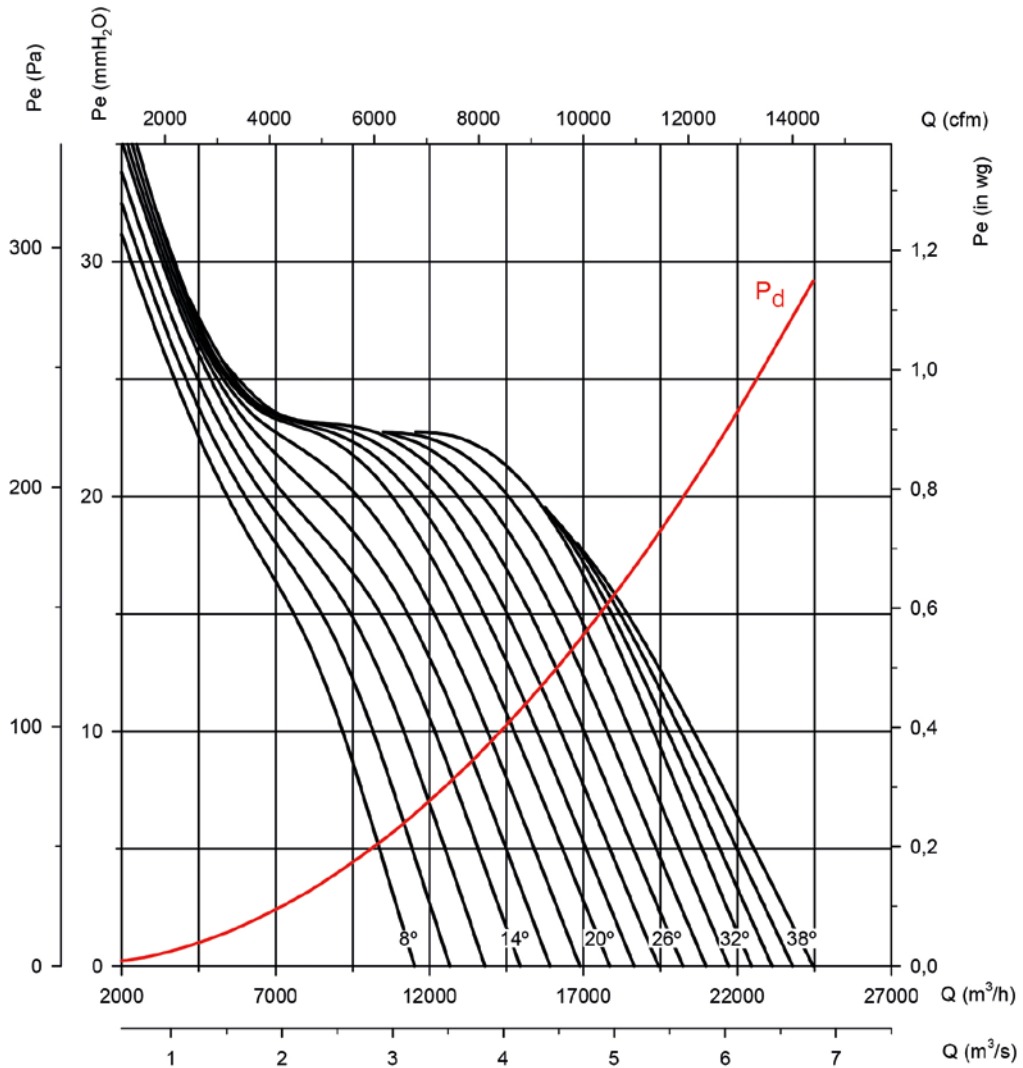

Potencia absorbida

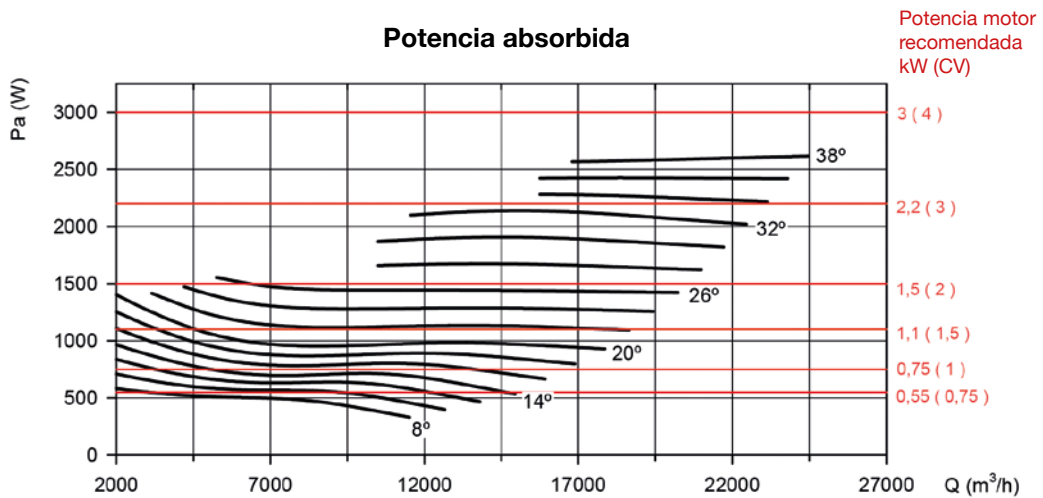

Curvas características

Q= Caudal en m³/h, m³/s y cfm

Pe= Presión estática en mmH₂O, Pa e inwg

Diámetro hélice en cm: 63

Número de polos motor: 6

Número de palas: 6

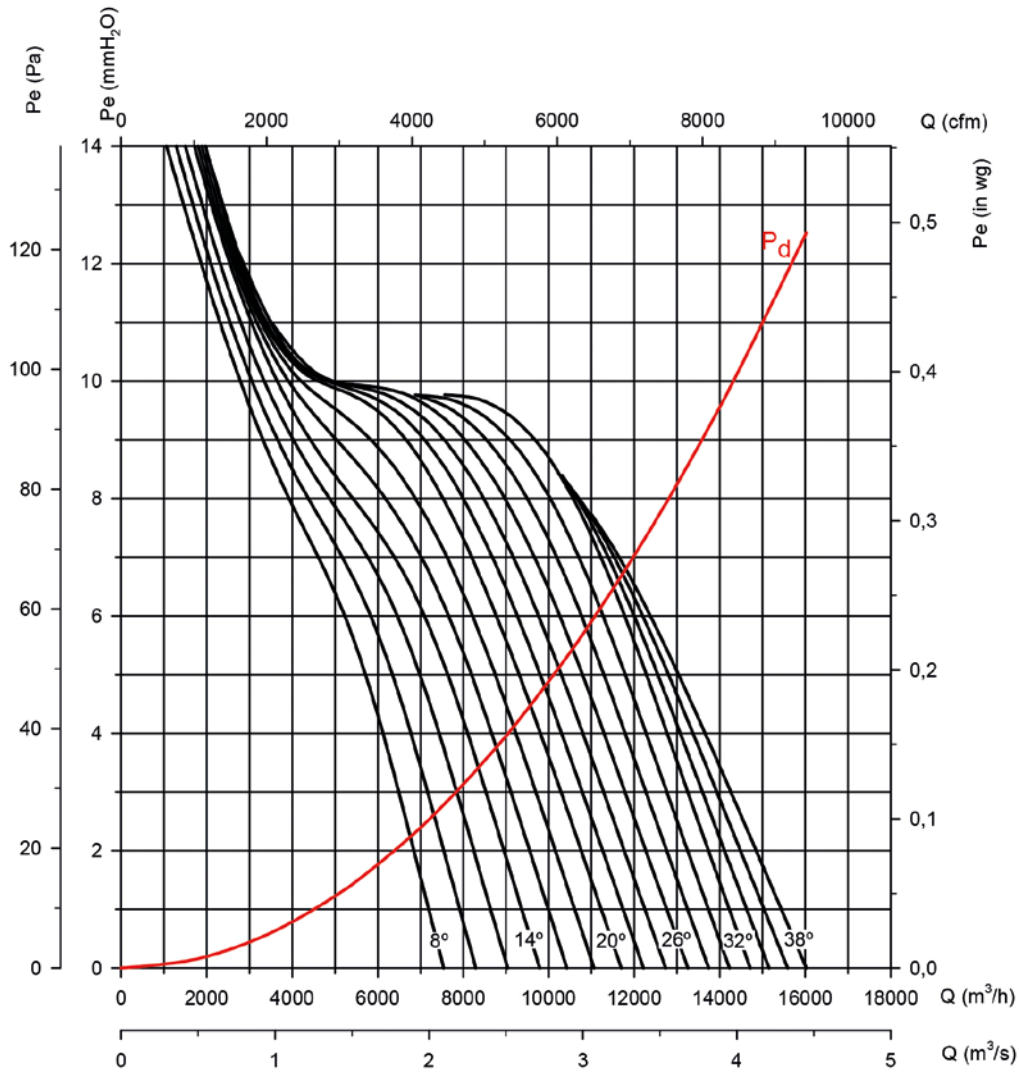

Potencia absorbida

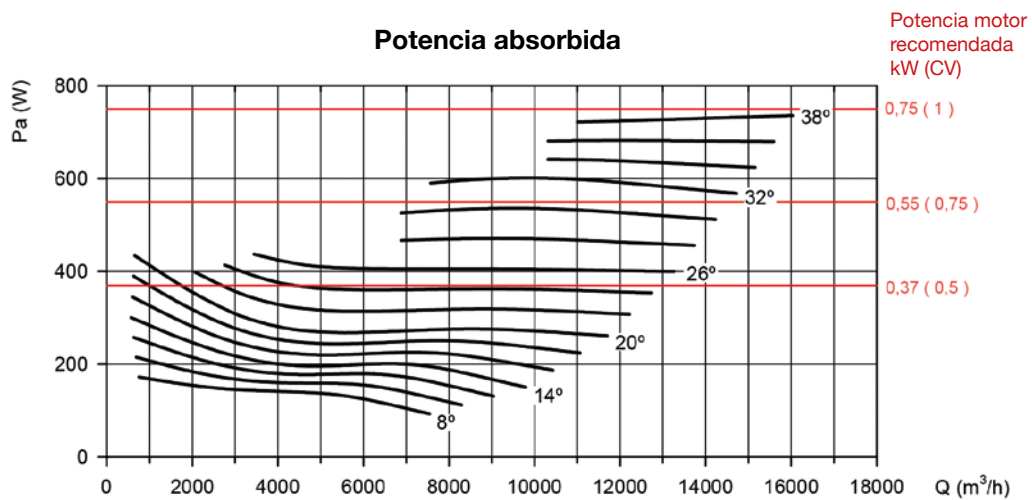

Curvas características

Q= Caudal en m³/h, m³/s y cfm

Pe= Presión estática en mmH₂O, Pa e inwg

Diámetro hélice en cm: 71

Número de polos motor: 4

Número de palas: 6

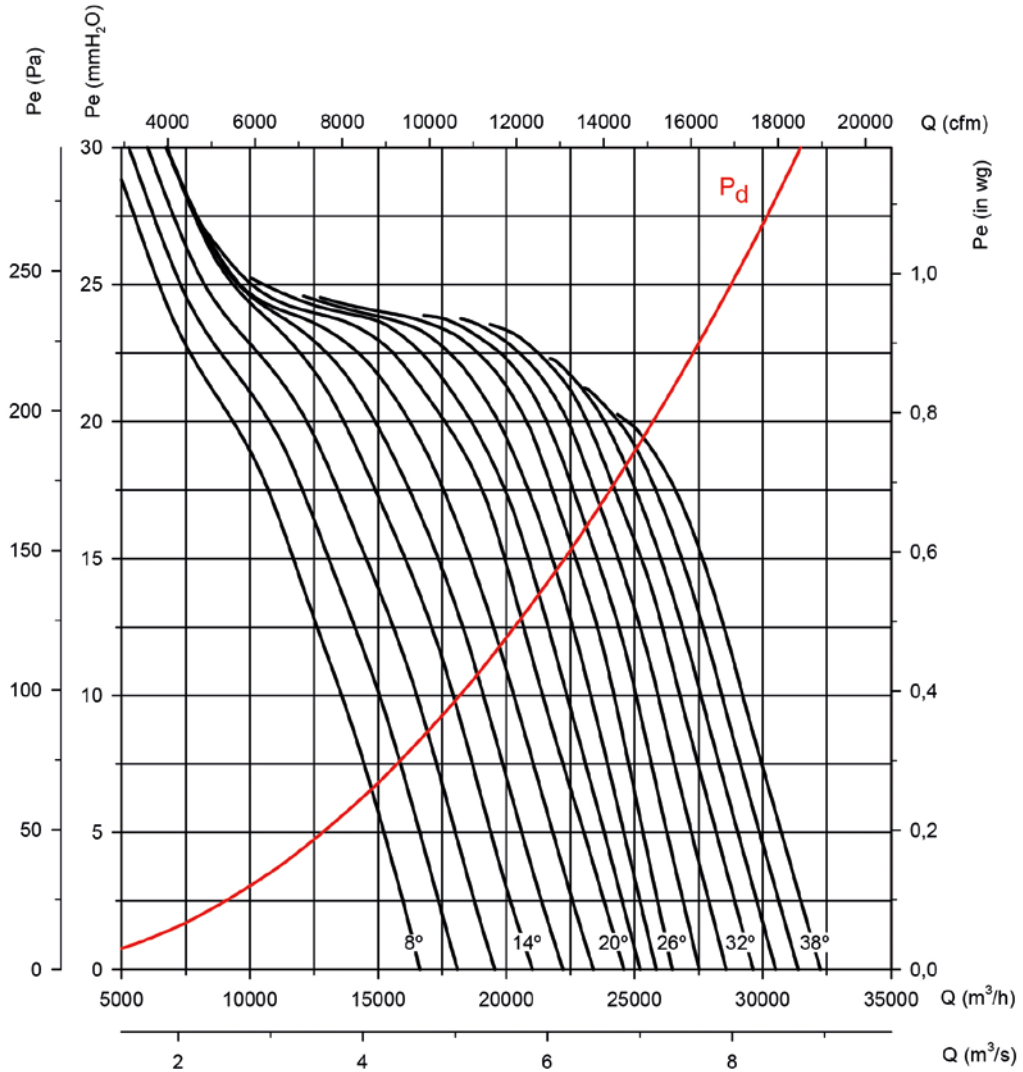

Potencia absorbida

Potencia motor recomendada kW (CV)

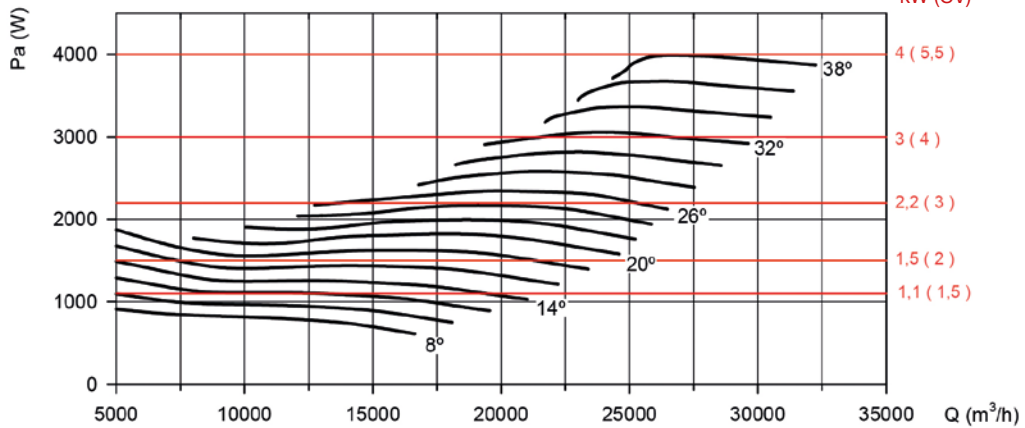

Curvas características

Q= Caudal en m³/h, m³/s y cfm

Pe= Presión estática en mmH₂O, Pa e inwg

Diámetro hélice en cm: 71

Número de polos motor: 6

Número de palas: 6

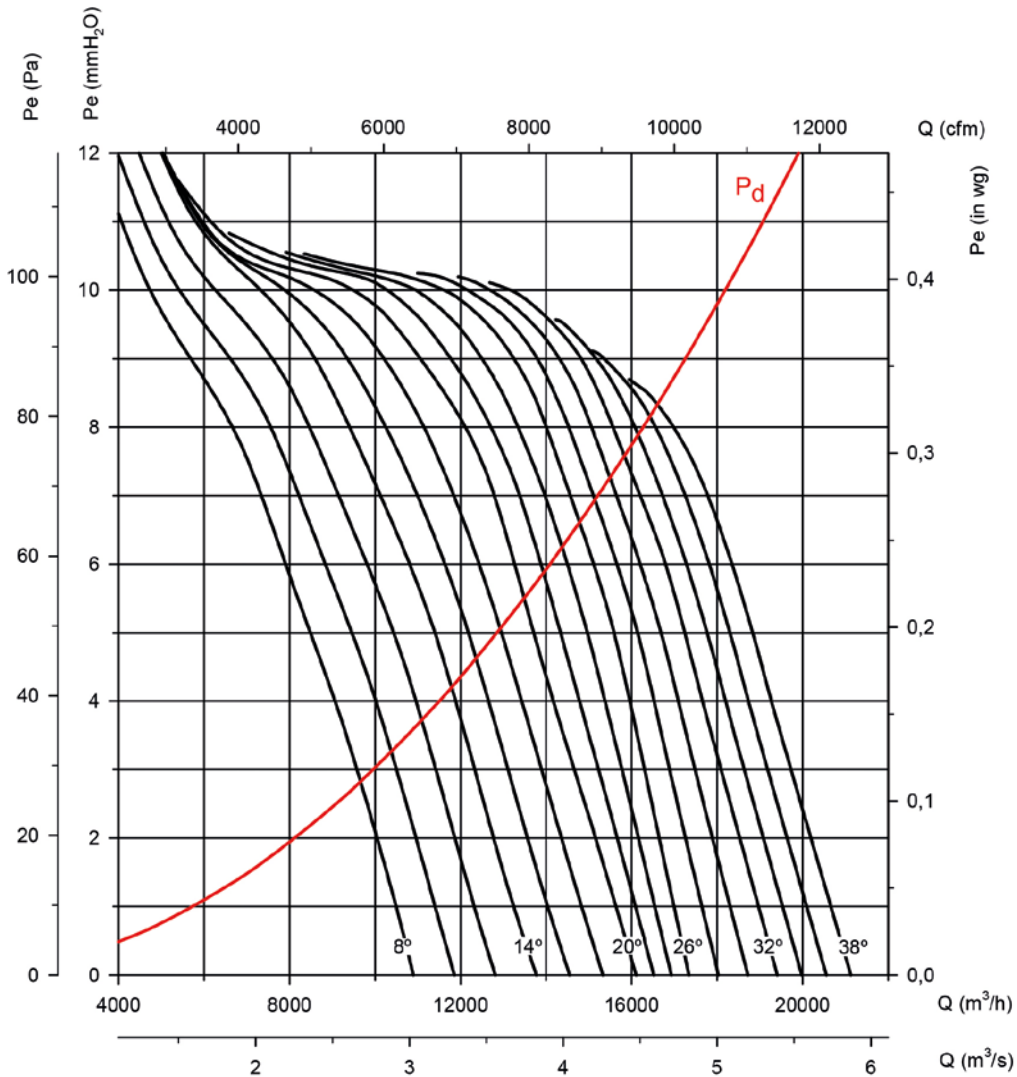

Potencia absorbida

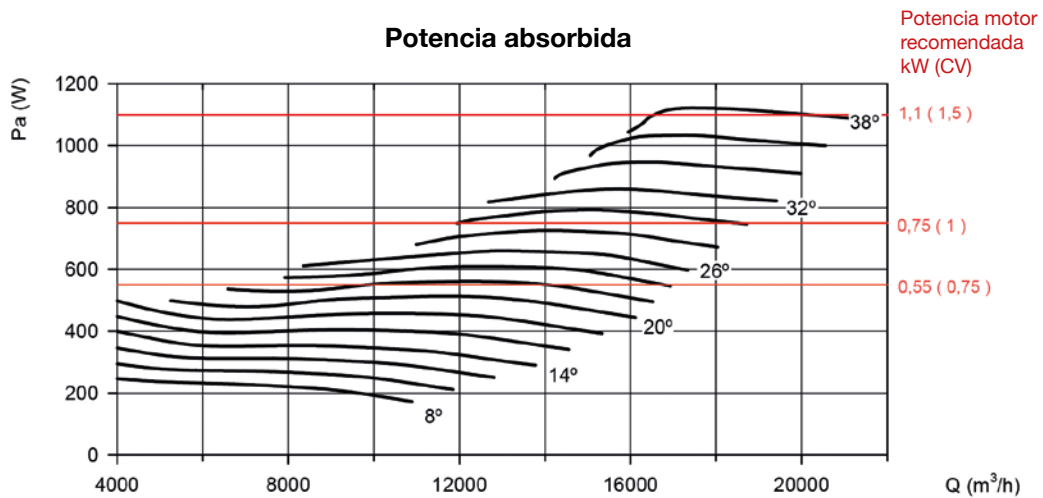

Curvas características

Q= Caudal en m³/h, m³/s y cfm

Pe= Presión estática en mmH₂O, Pa e inwg

Diámetro hélice en cm: 80

Número de polos motor: 4

Número de palas: 6

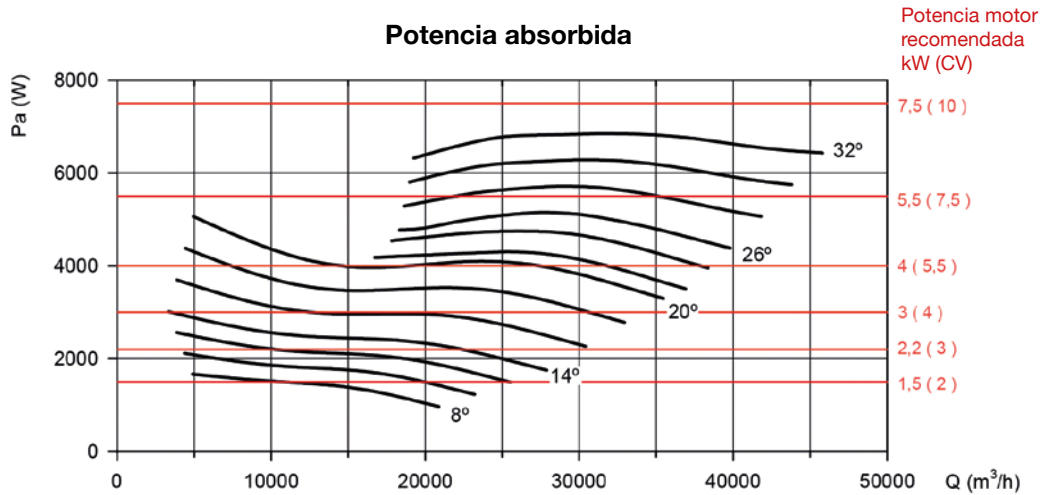
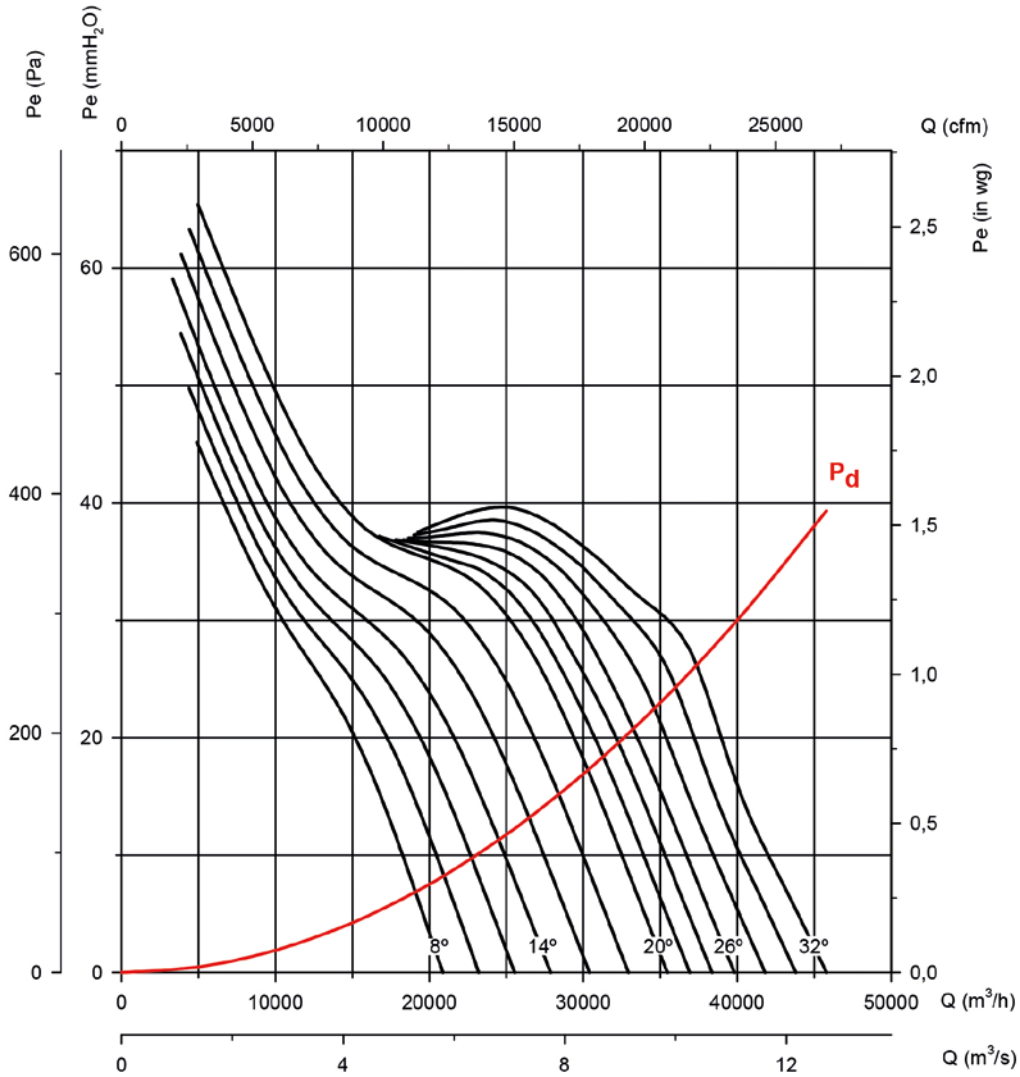

Curvas características

Q= Caudal en m³/h, m³/s y cfm

Pe= Presión estática en mmH₂O, Pa e inwg

Diámetro hélice en cm: 80

Número de polos motor: 6

Número de palas: 6

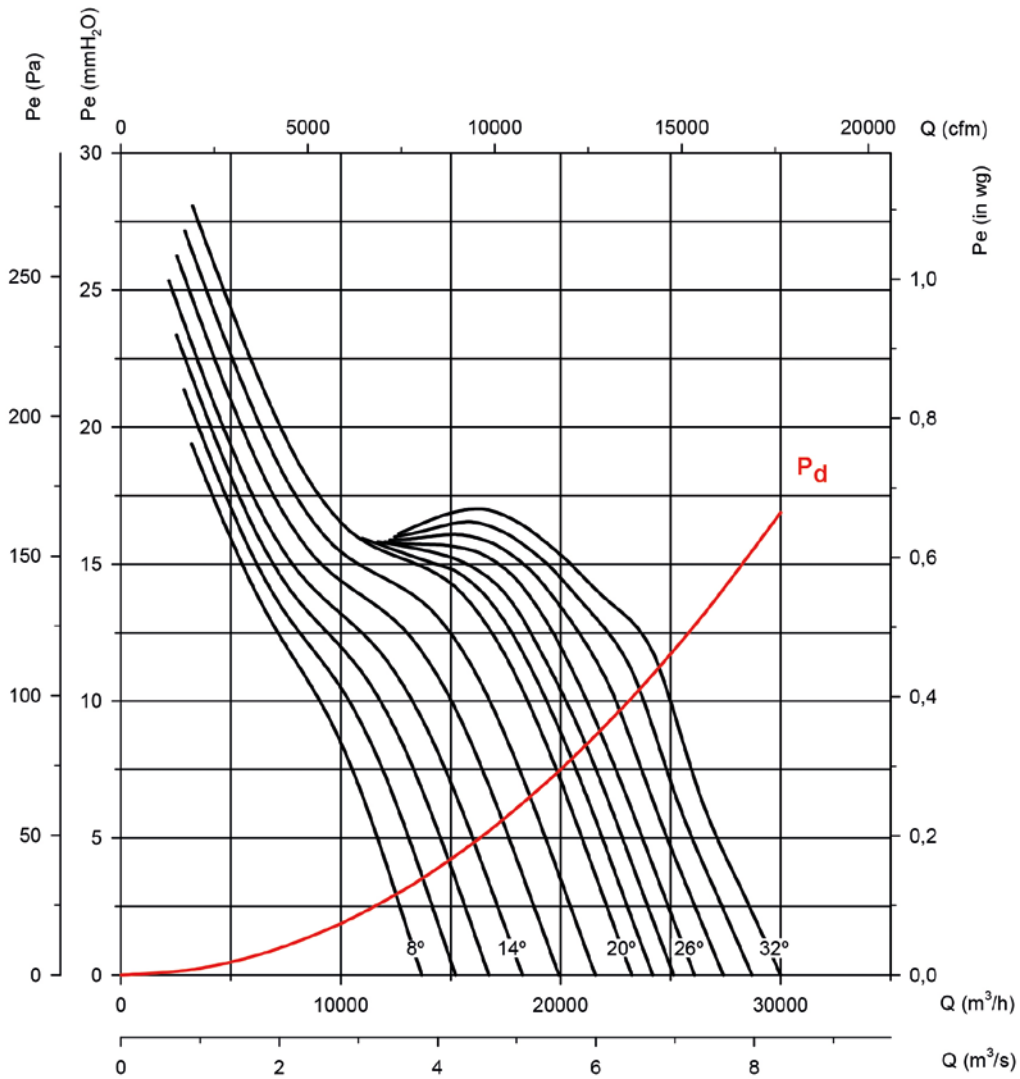

Potencia absorbida

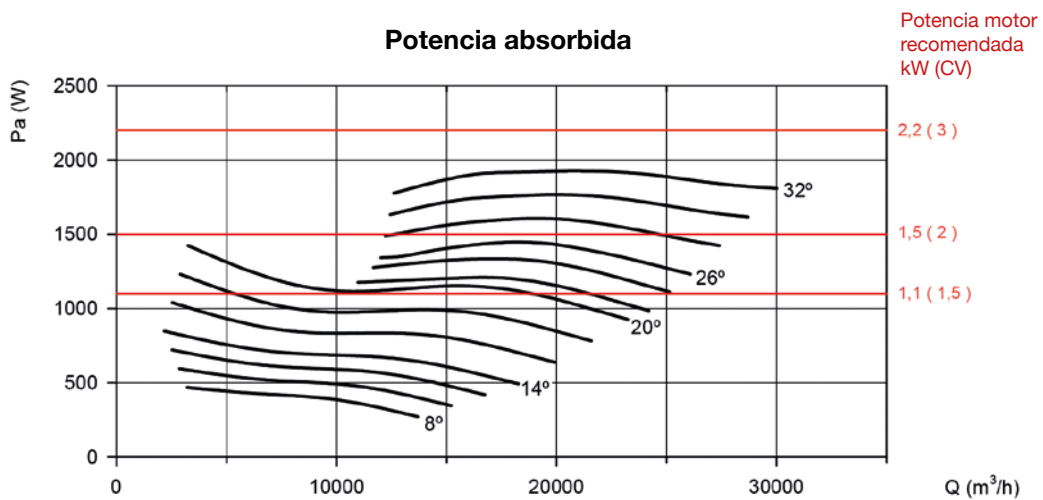

Curvas características

Q= Caudal en m³/h, m³/s y cfm

Pe= Presión estática en mmH₂O, Pa e inwg

Diámetro hélice en cm: 80

Número de polos motor: 8

Número de palas: 6

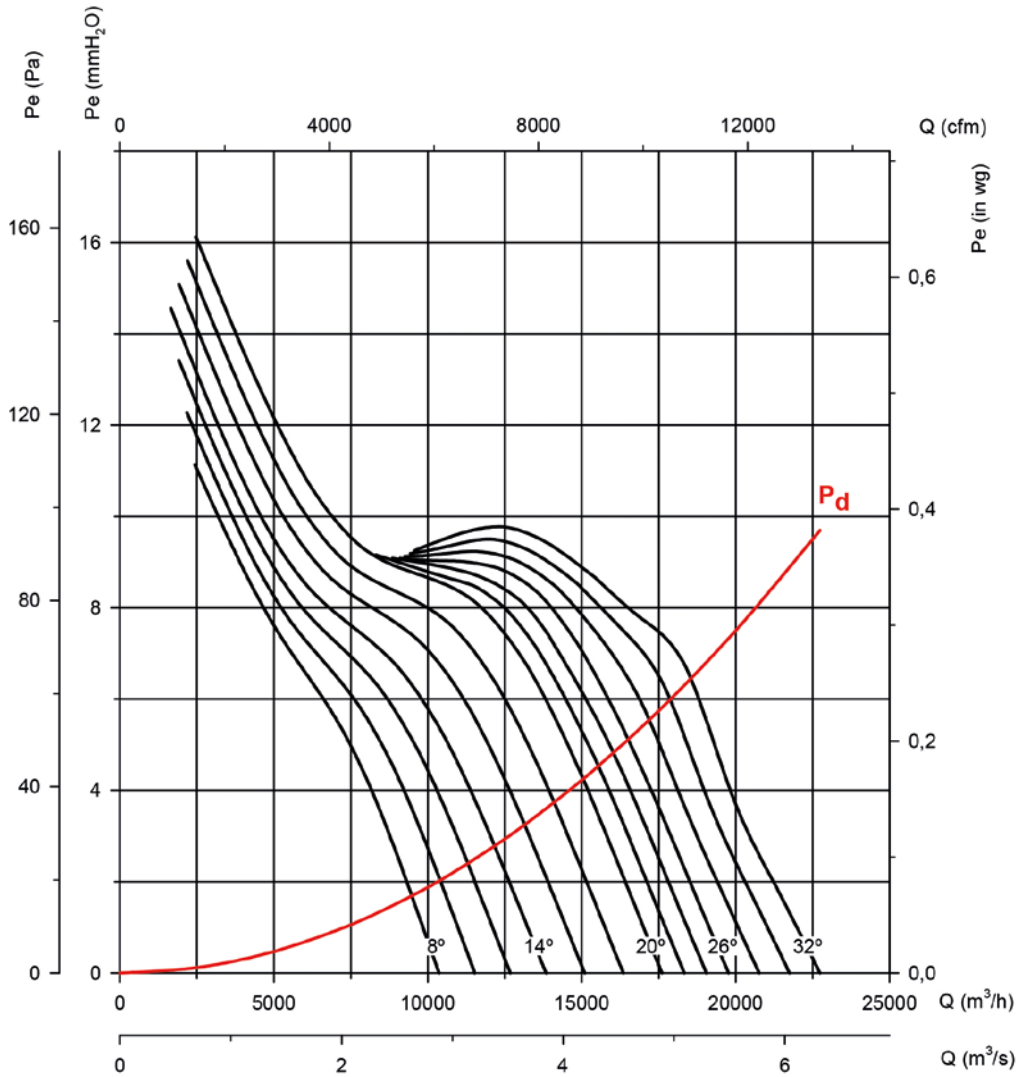

Potencia absorbida

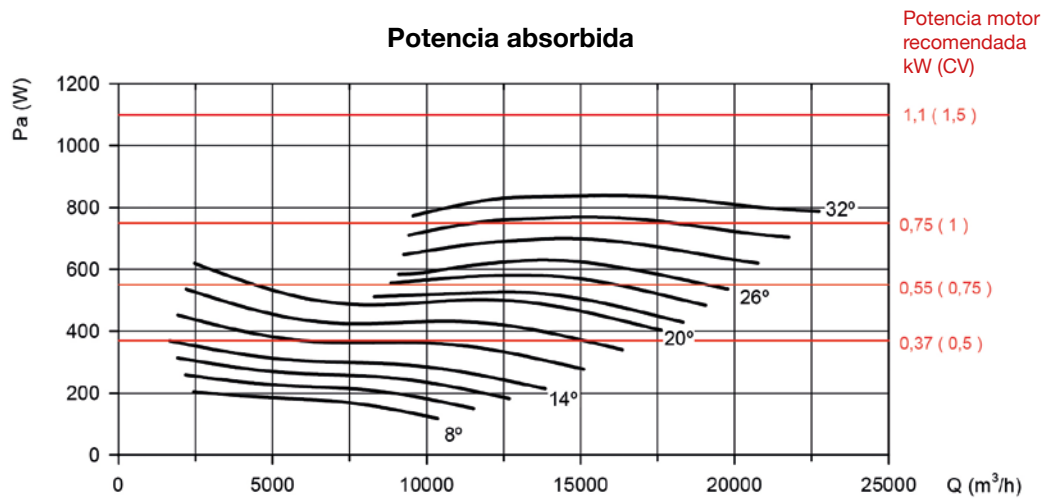

Curvas características

Q= Caudal en m³/h, m³/s y cfm

Pe= Presión estática en mmH₂O, Pa e inwg

Diámetro hélice en cm: 90

Número de polos motor: 4

Número de palas: 6

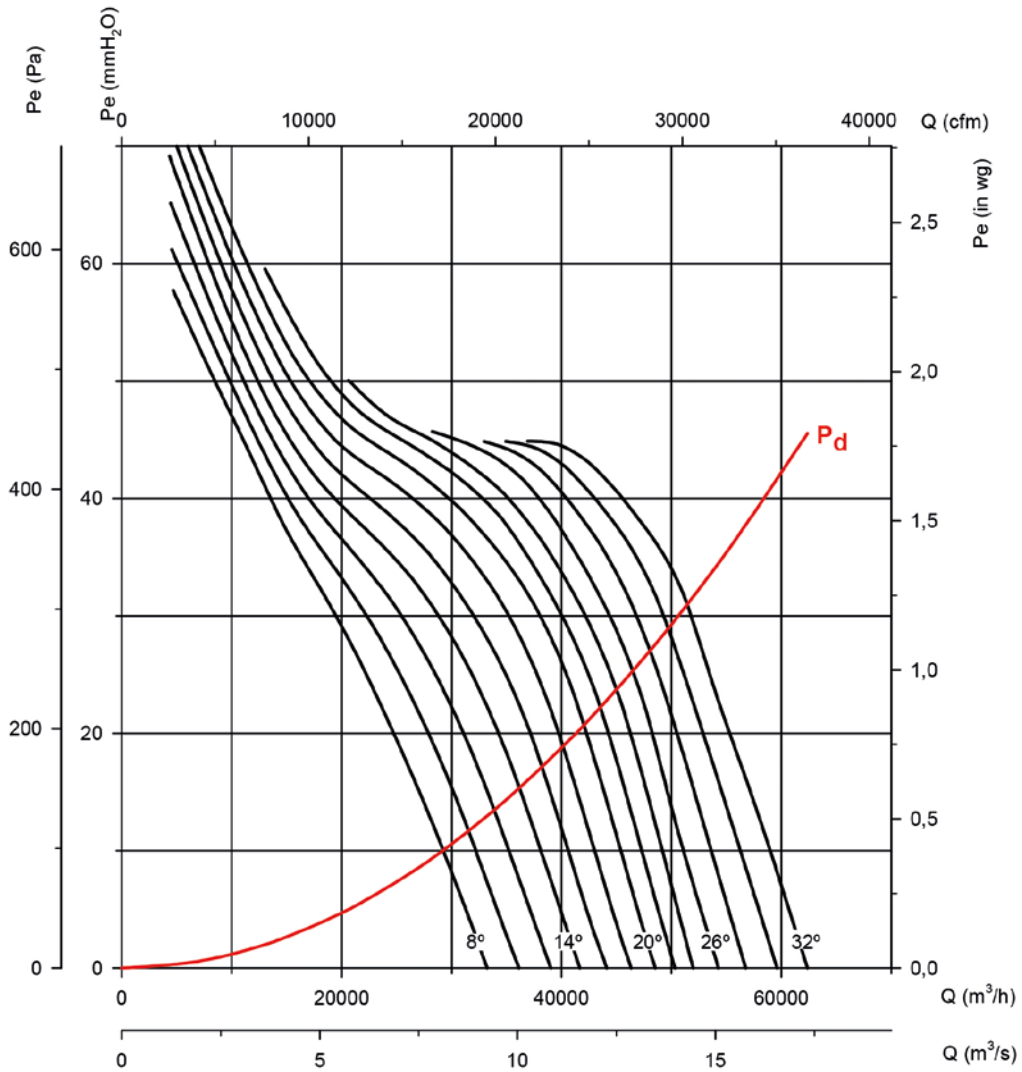

Potencia absorbida

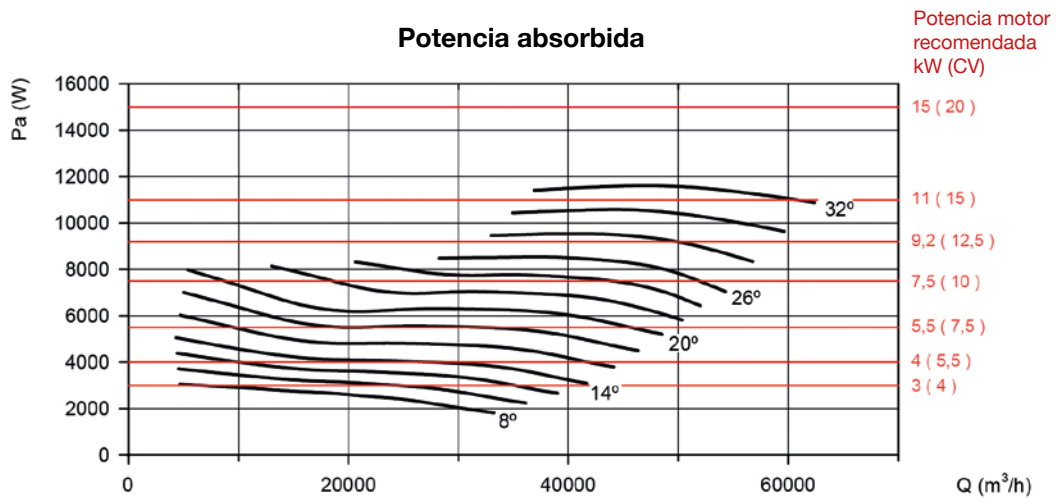

Curvas características

Q= Caudal en m³/h, m³/s y cfm

Pe= Presión estática en mmH₂O, Pa e inwg

Diámetro hélice en cm: 90

Número de polos motor: 6

Número de palas: 6

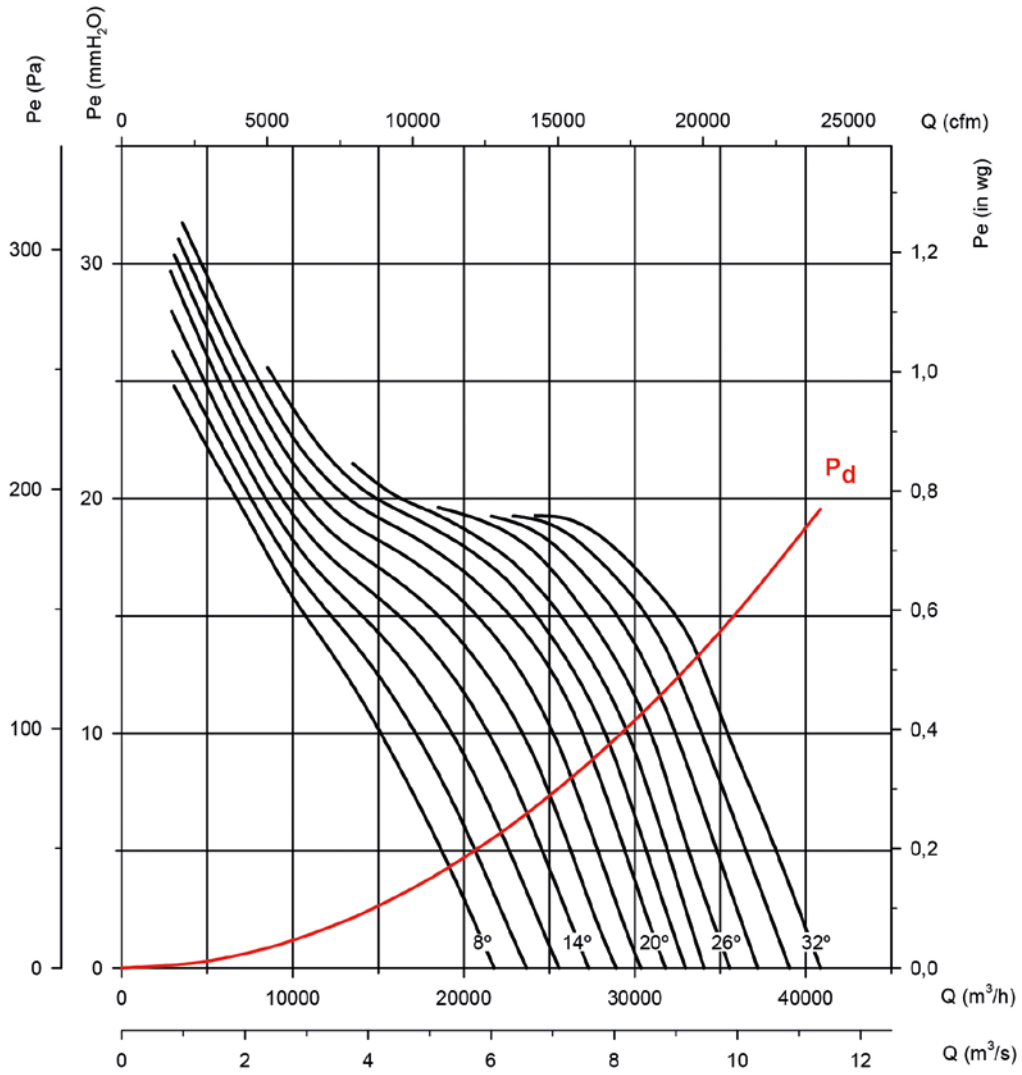

Potencia absorbida

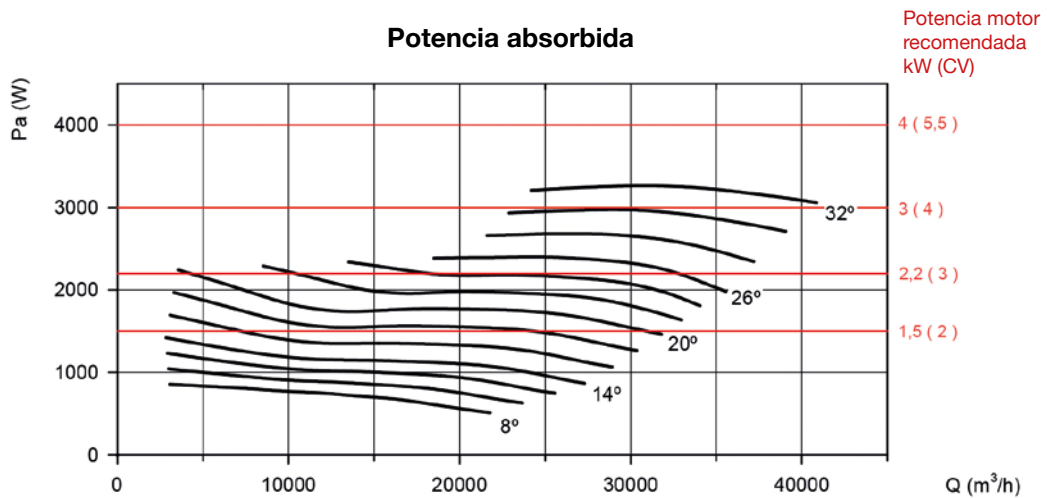

Curvas características

Q= Caudal en m³/h, m³/s y cfm

Pe= Presión estática en mmH₂O, Pa e inwg

Diámetro hélice en cm: 90

Número de polos motor: 8

Número de palas: 6

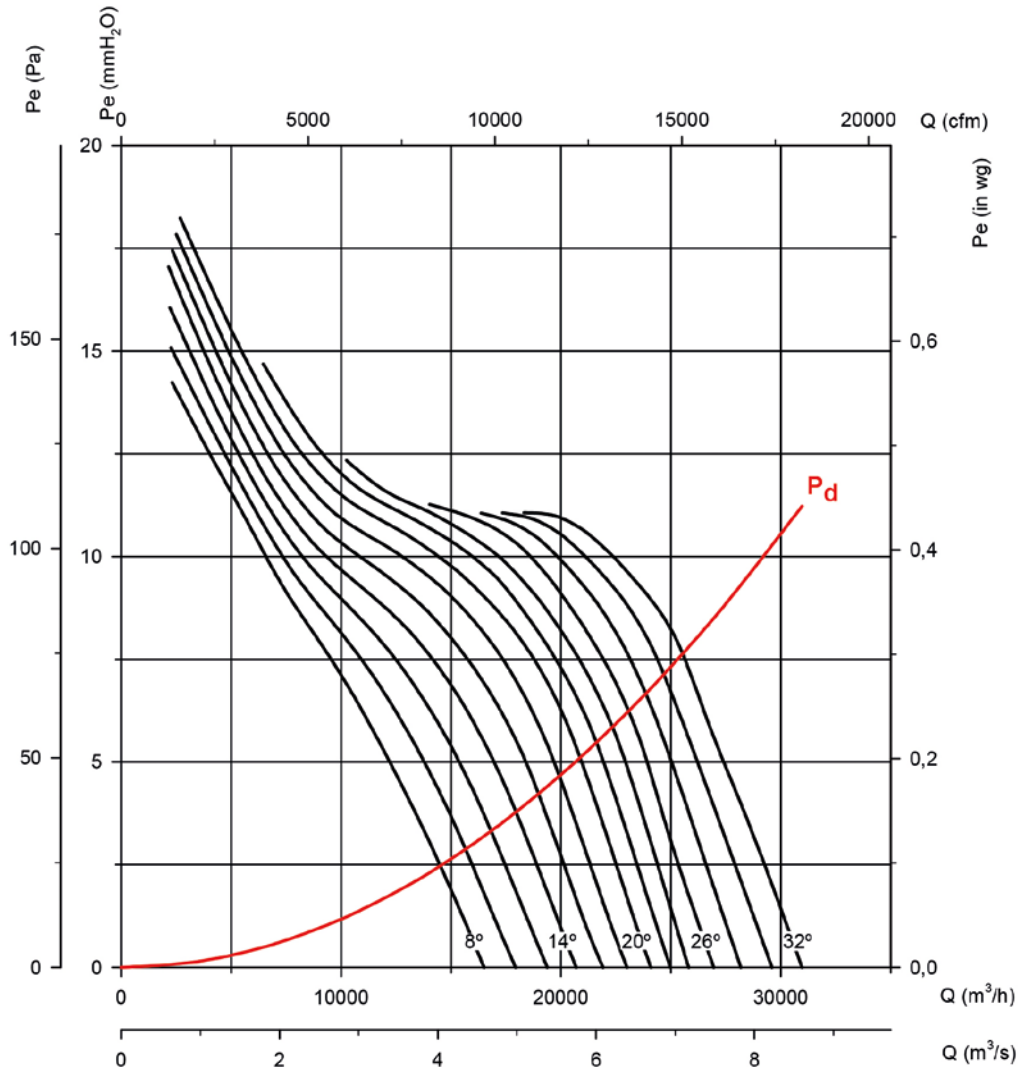

Potencia absorbida

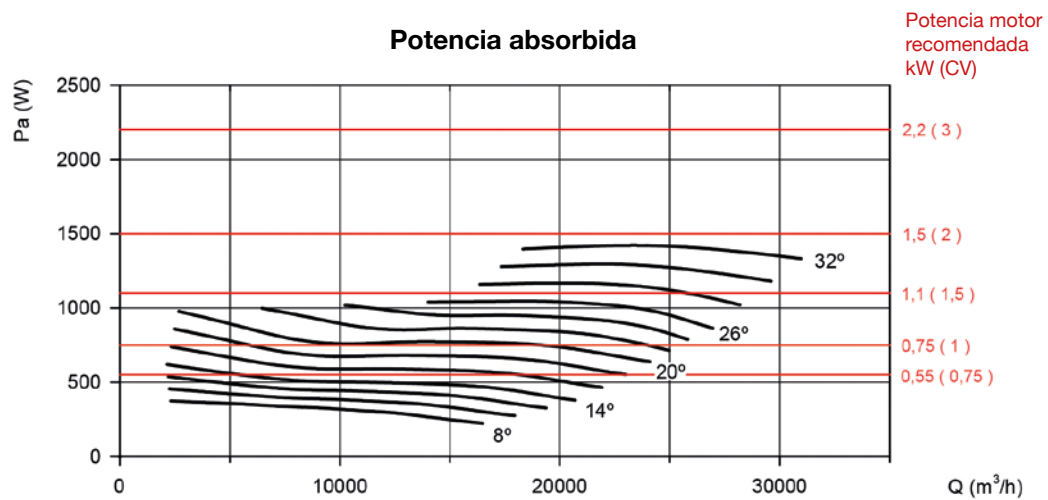

Curvas características

Q= Caudal en m³/h, m³/s y cfm

Pe= Presión estática en mmH₂O, Pa e inwg

Diámetro hélice en cm: 100

Número de polos motor: 4

Número de palas: 6

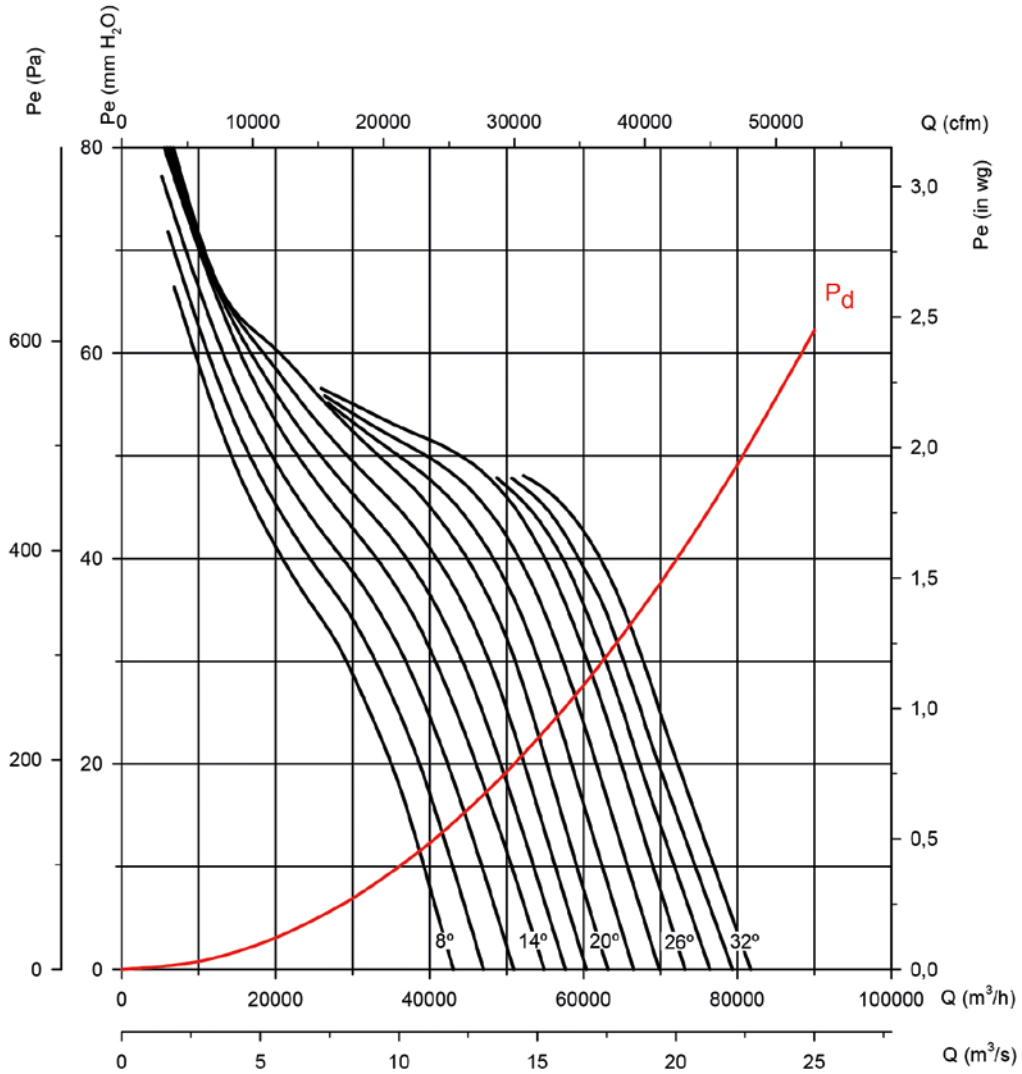

Potencia absorbida

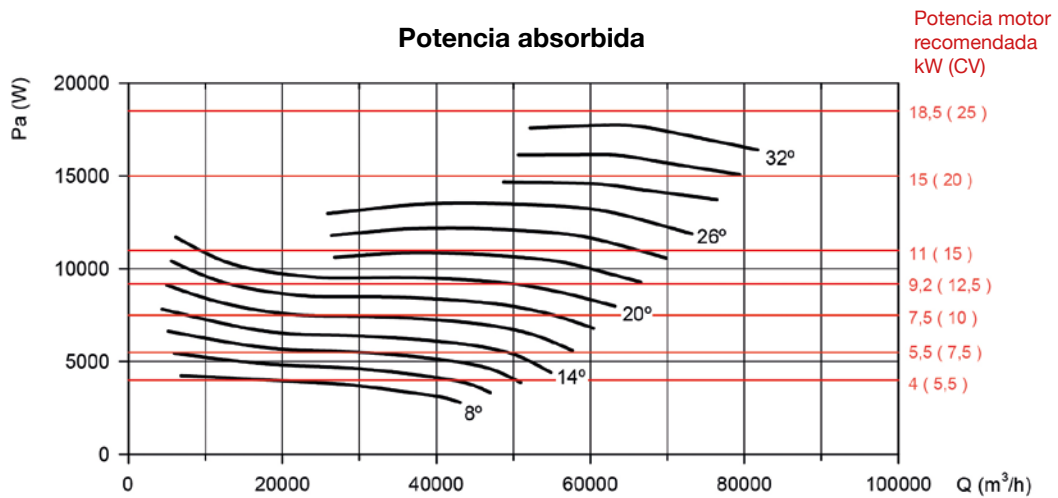

Curvas características

Q= Caudal en m³/h, m³/s y cfm

Pe= Presión estática en mmH₂O, Pa e inwg

Diámetro hélice en cm: 100

Número de polos motor: 4

Número de palas: 9

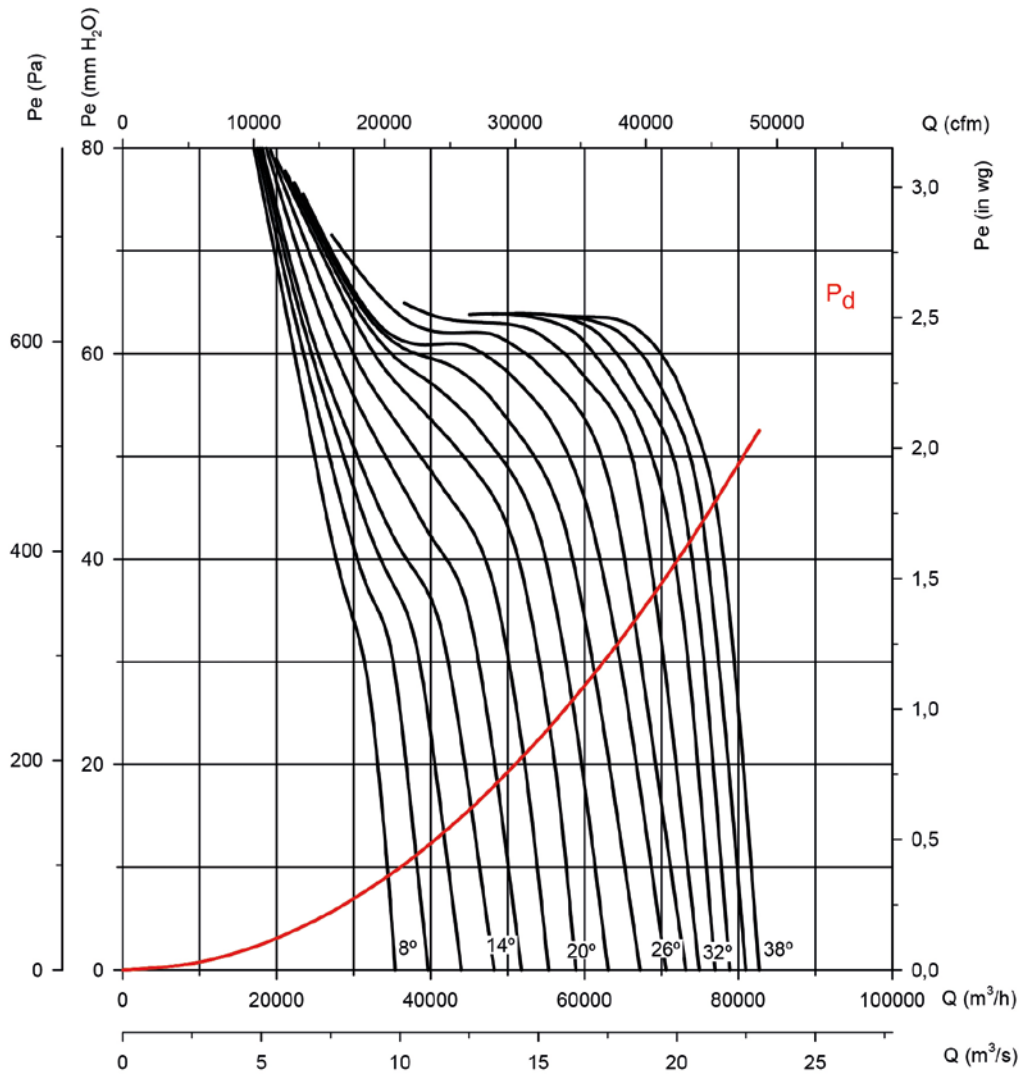

Potencia absorbida

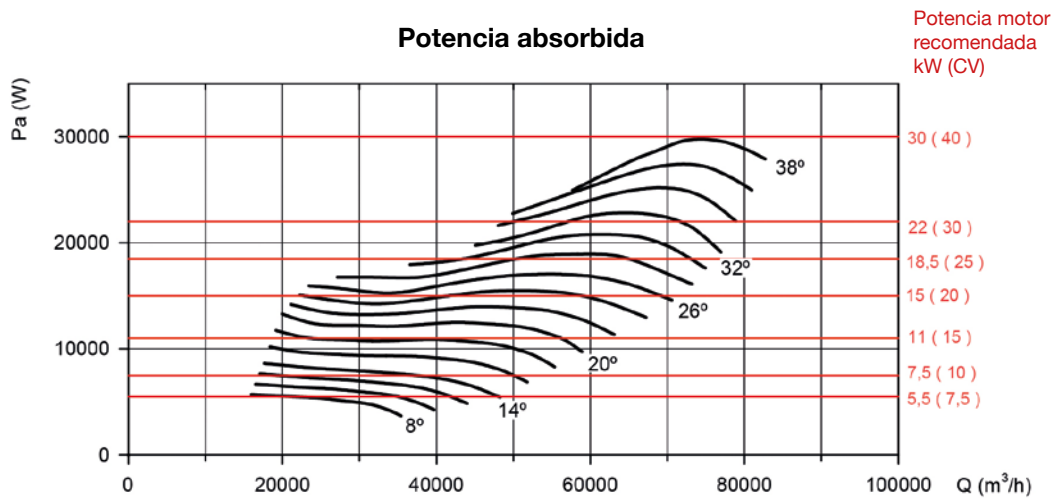

Curvas características

Q= Caudal en m³/h, m³/s y cfm

Pe= Presión estática en mmH₂O, Pa e inwg

Diámetro hélice en cm: 100

Número de polos motor: 6

Número de palas: 6

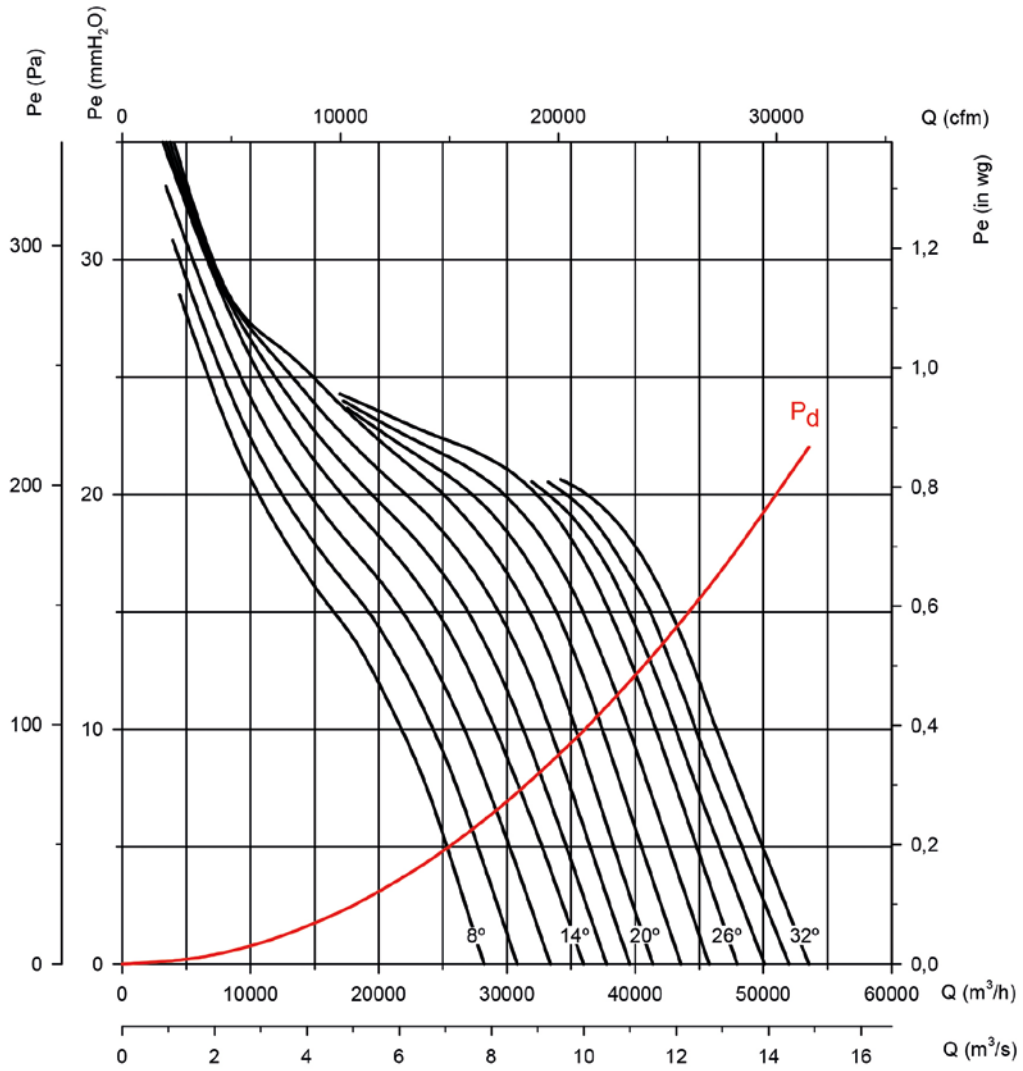

Potencia absorbida

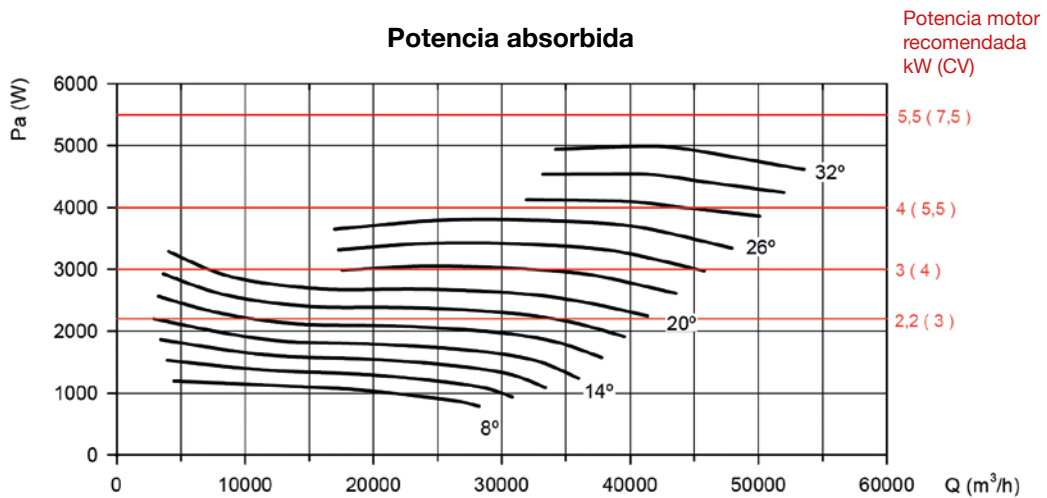

Curvas características

Q= Caudal en m³/h, m³/s y cfm

Pe= Presión estática en mmH₂O, Pa e inwg

Diámetro hélice en cm: 100

Número de polos motor: 6

Número de palas: 9

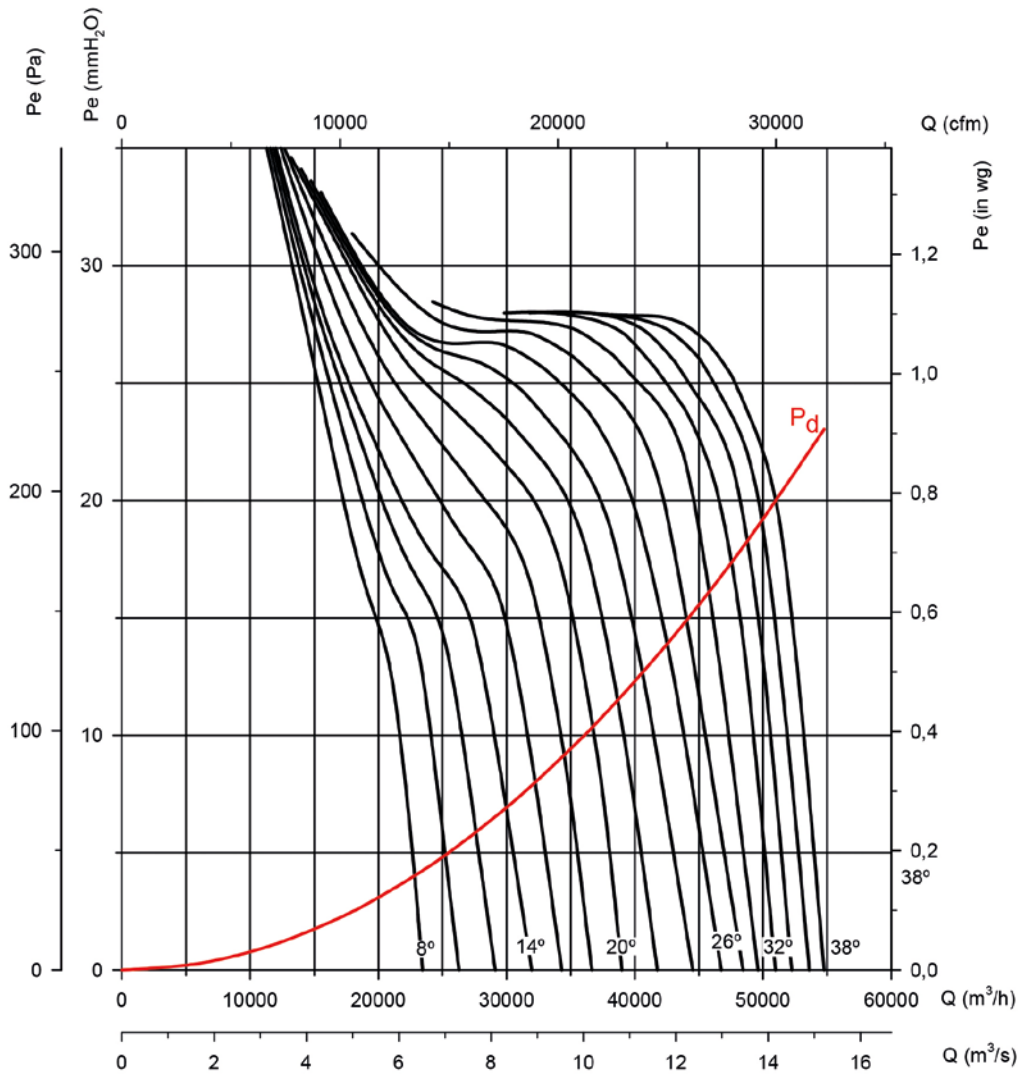

Potencia absorbida

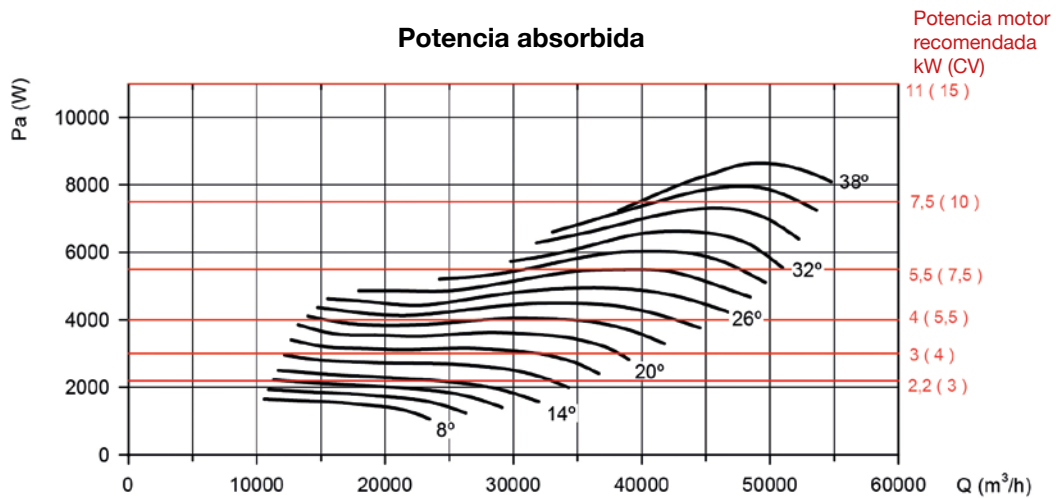

Curvas características

Q= Caudal en m³/h, m³/s y cfm

Pe= Presión estática en mmH₂O, Pa e inwg

Diámetro hélice en cm: 100

Número de polos motor: 8

Número de palas: 6

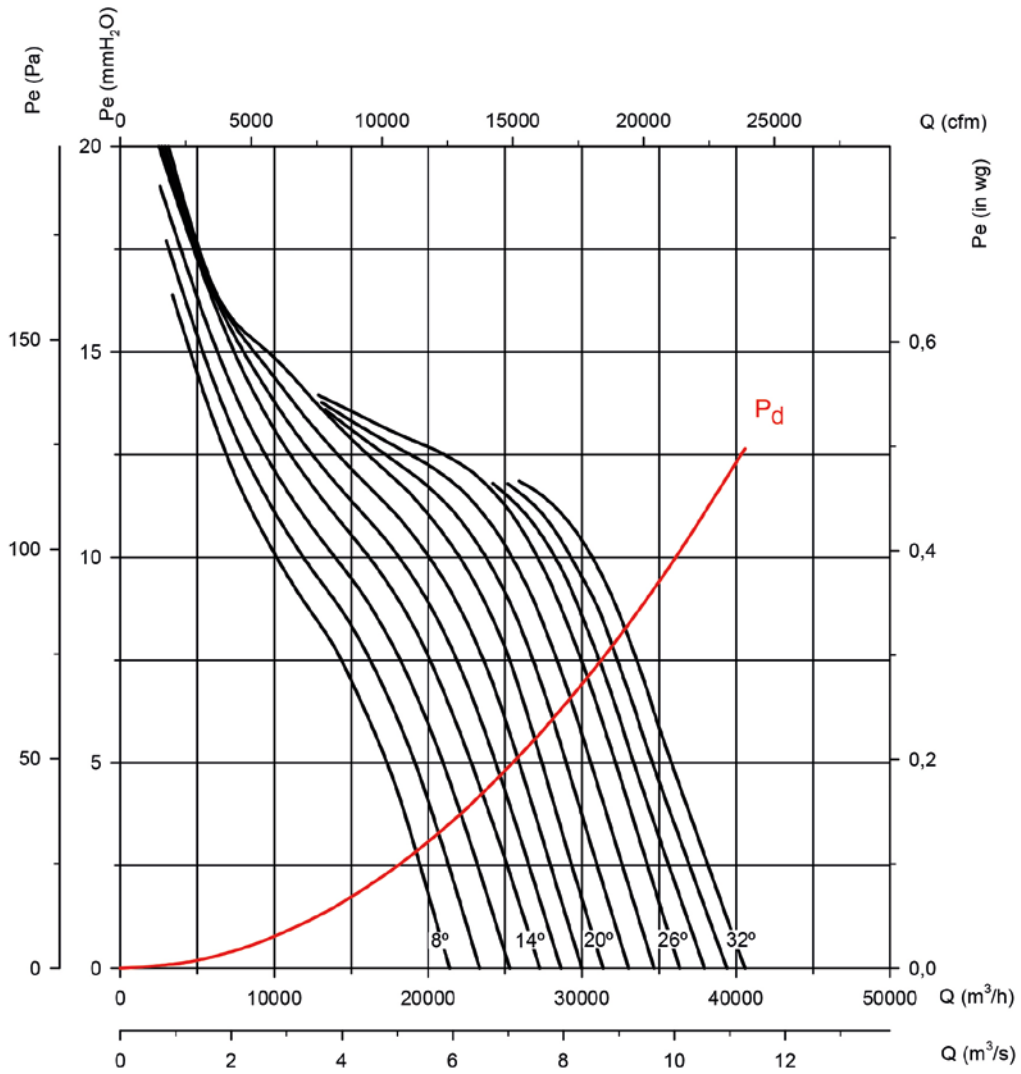

Potencia absorbida

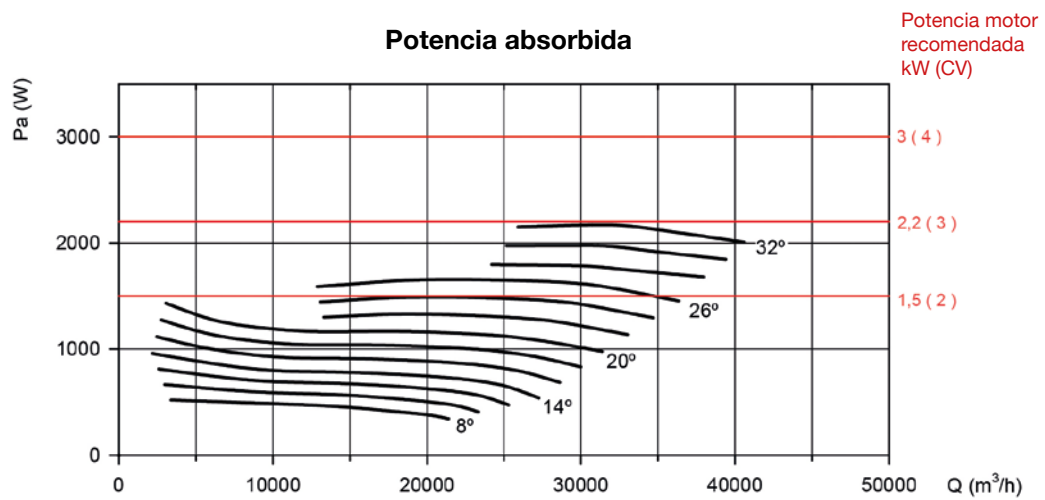

Curvas características

Q= Caudal en m³/h, m³/s y cfm

Pe= Presión estática en mmH₂O, Pa e inwg

Diámetro hélice en cm: 125

Número de polos motor: 4

Número de palas: 6

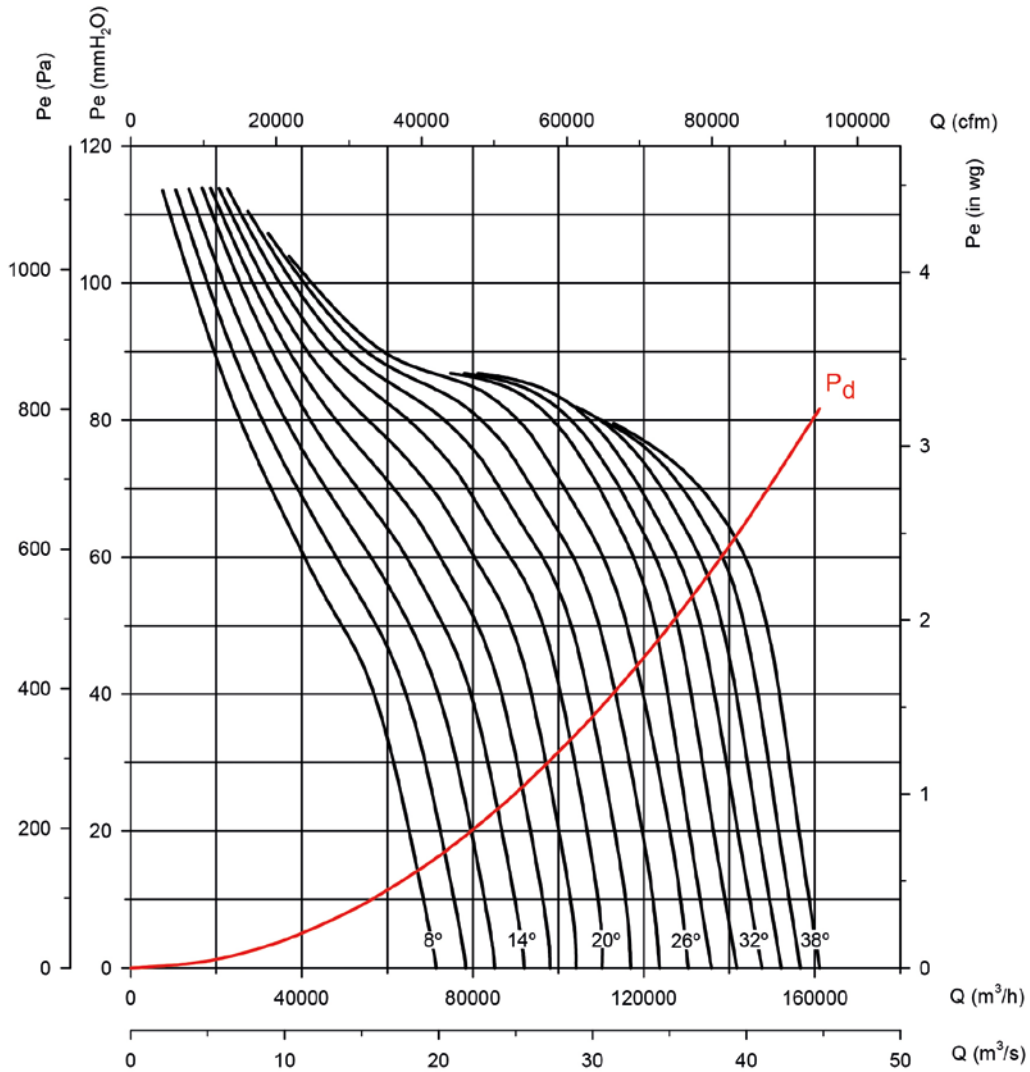

Potencia absorbida

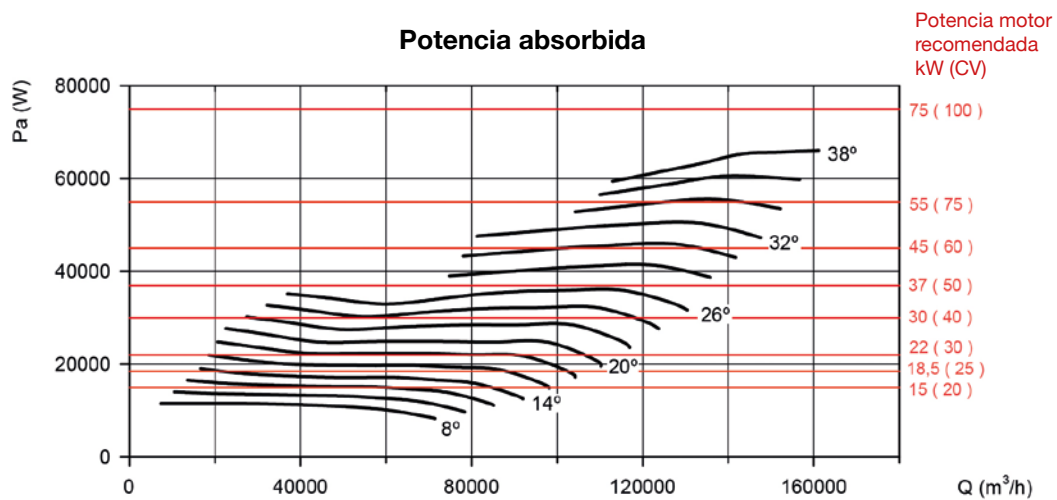

Curvas características

Q= Caudal en m³/h, m³/s y cfm

Pe= Presión estática en mmH₂O, Pa e inwg

Diámetro hélice en cm: 125

Número de polos motor: 4

Número de palas: 9

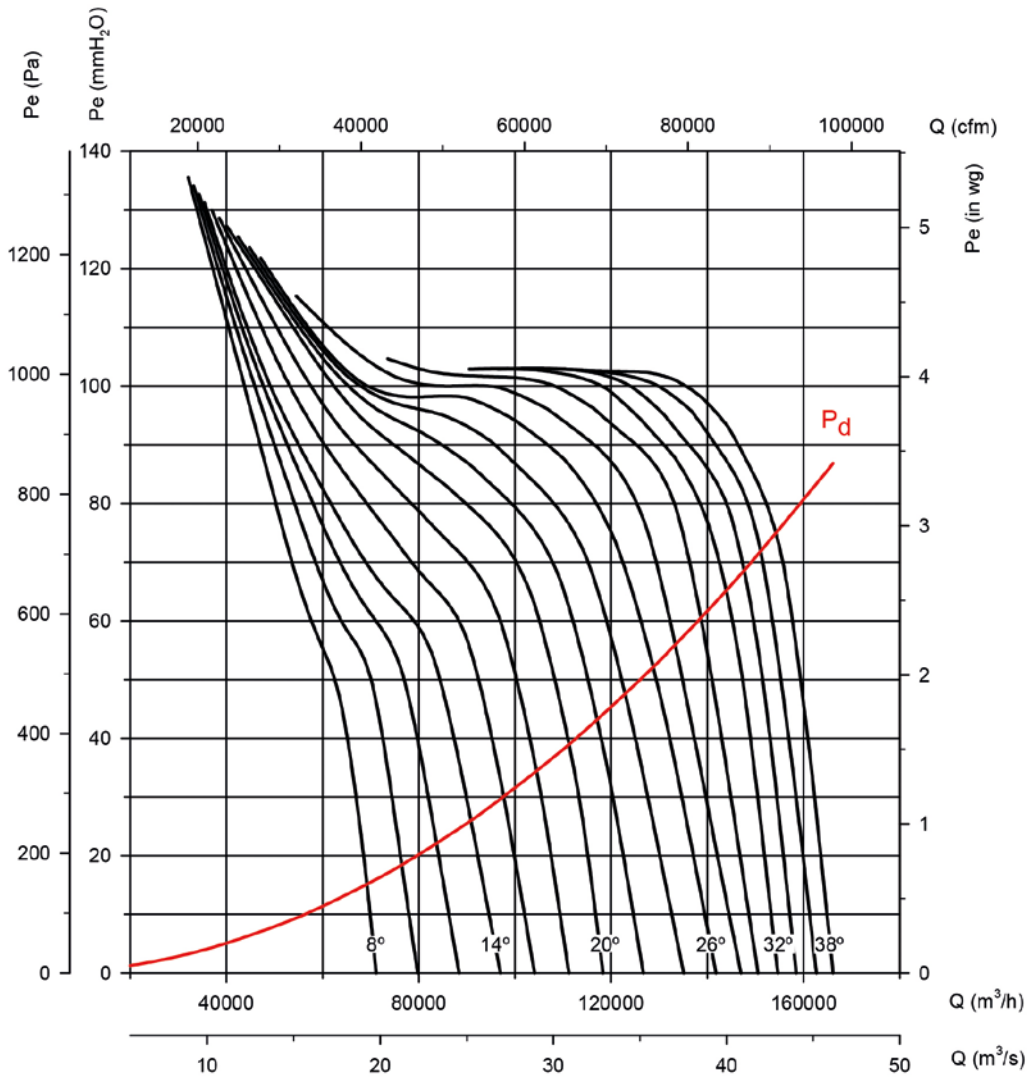

Potencia absorbida

Potencia motor recomendada kW (CV)

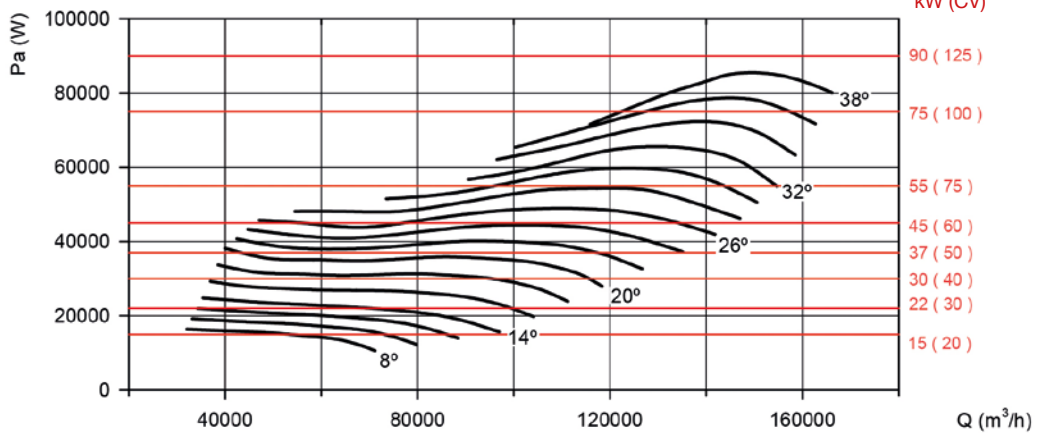

Curvas características

Q= Caudal en m³/h, m³/s y cfm

Pe= Presión estática en mmH₂O, Pa e inwg

Diámetro hélice en cm: 125

Número de polos motor: 4

Número de palas: 12

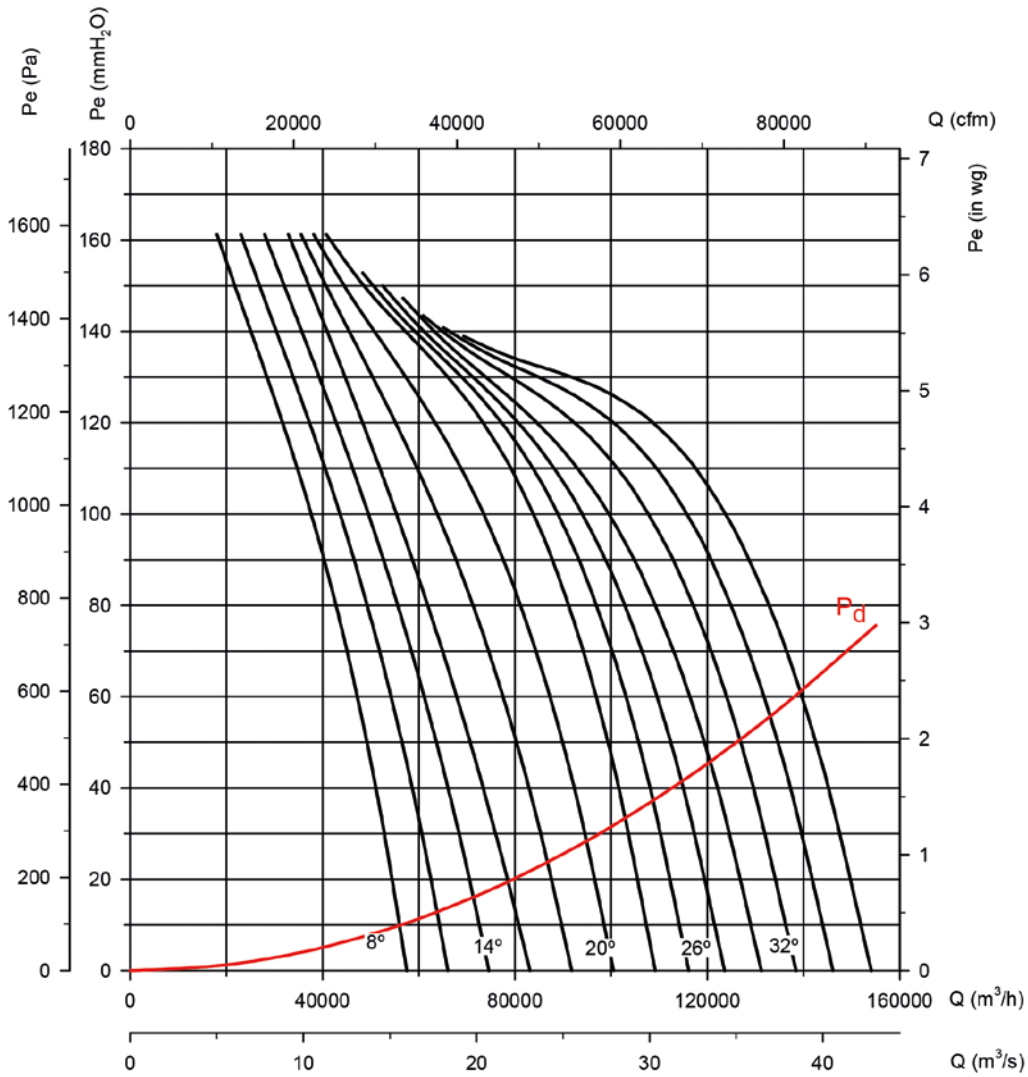

Potencia absorbida

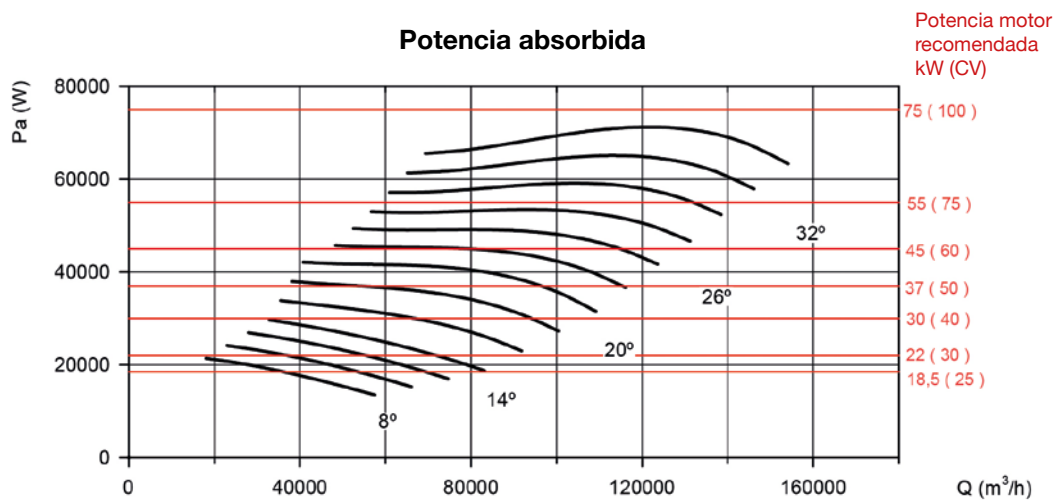

Curvas características

Q= Caudal en m³/h, m³/s y cfm

Pe= Presión estática en mmH₂O, Pa e inwg

Diámetro hélice en cm: 125

Número de polos motor: 6

Número de palas: 6

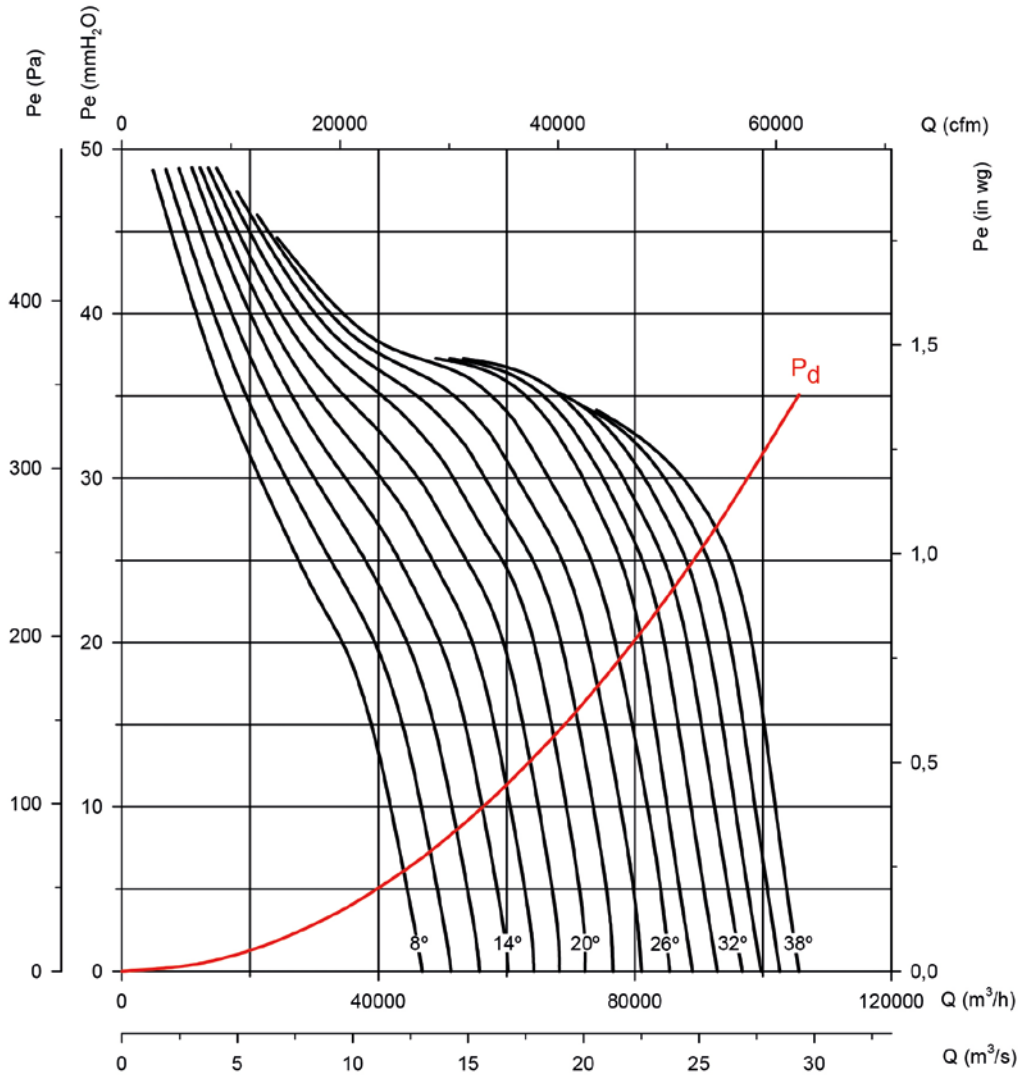

Potencia absorbida

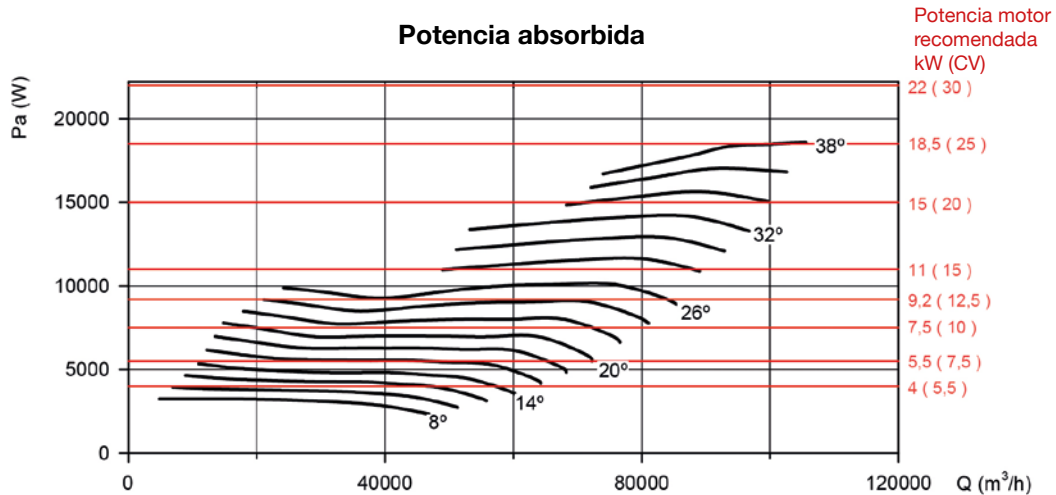

Curvas características

Q= Caudal en m³/h, m³/s y cfm

Pe= Presión estática en mmH₂O, Pa e inwg

Diámetro hélice en cm: 125

Número de polos motor: 6

Número de palas: 9

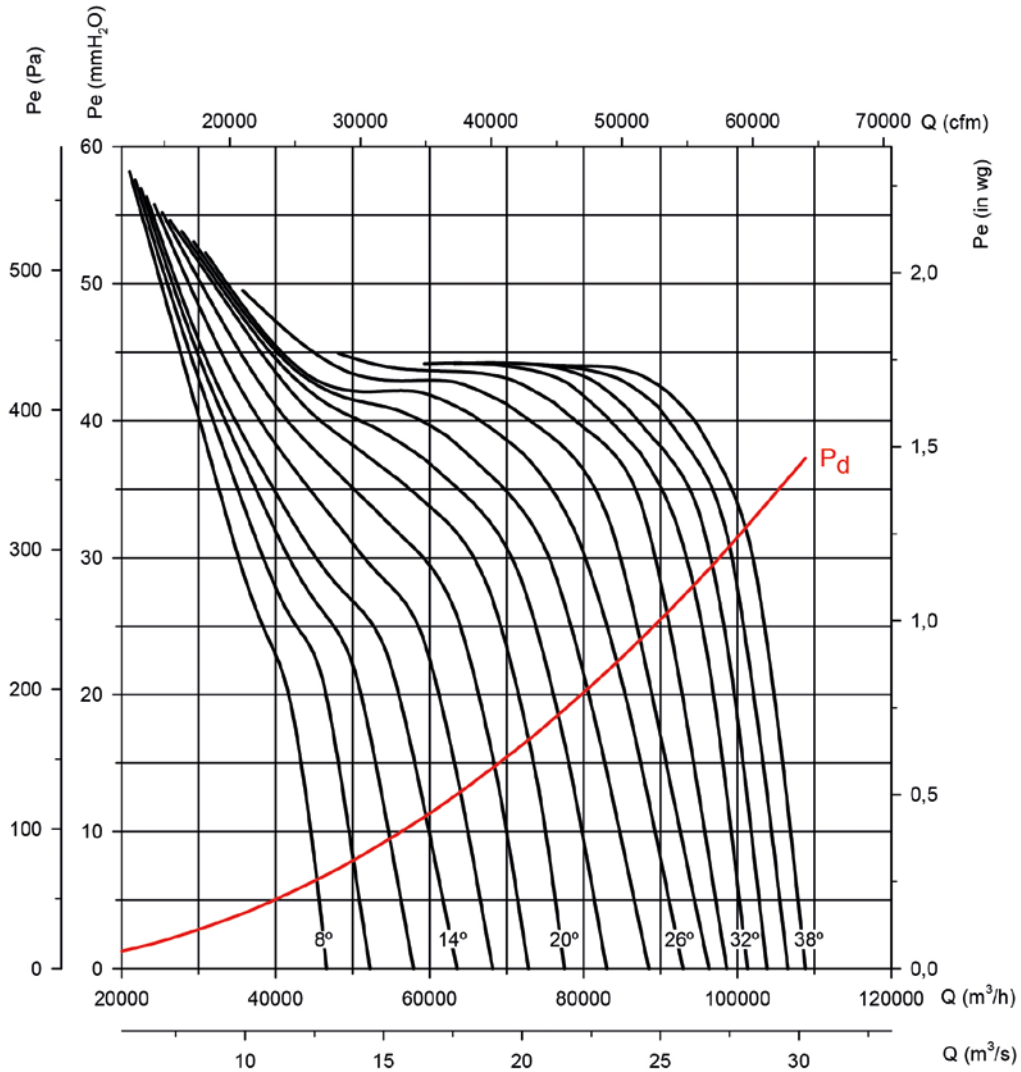

Potencia absorbida

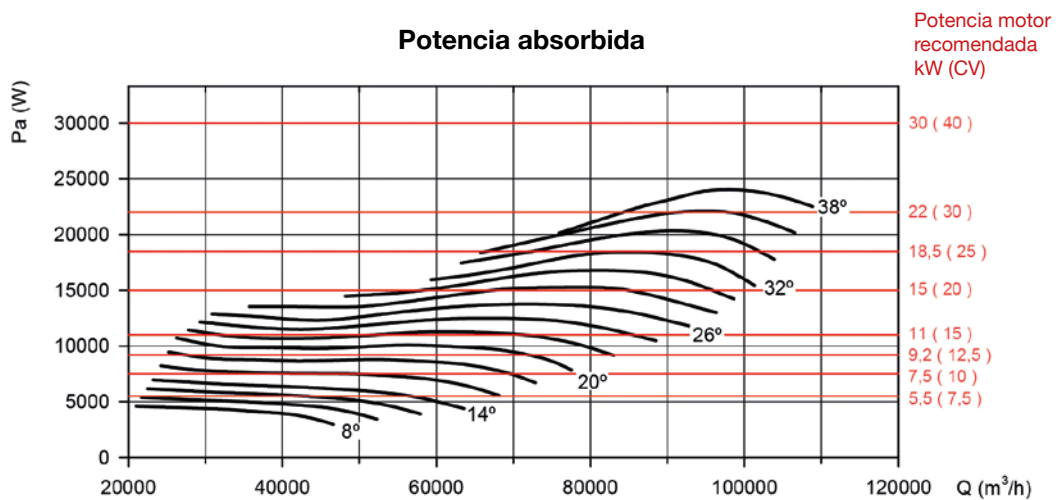

Curvas características

Q= Caudal en m³/h, m³/s y cfm

Pe= Presión estática en mmH₂O, Pa e inwg

Diámetro hélice en cm: 125

Número de polos motor: 6

Número de palas: 12

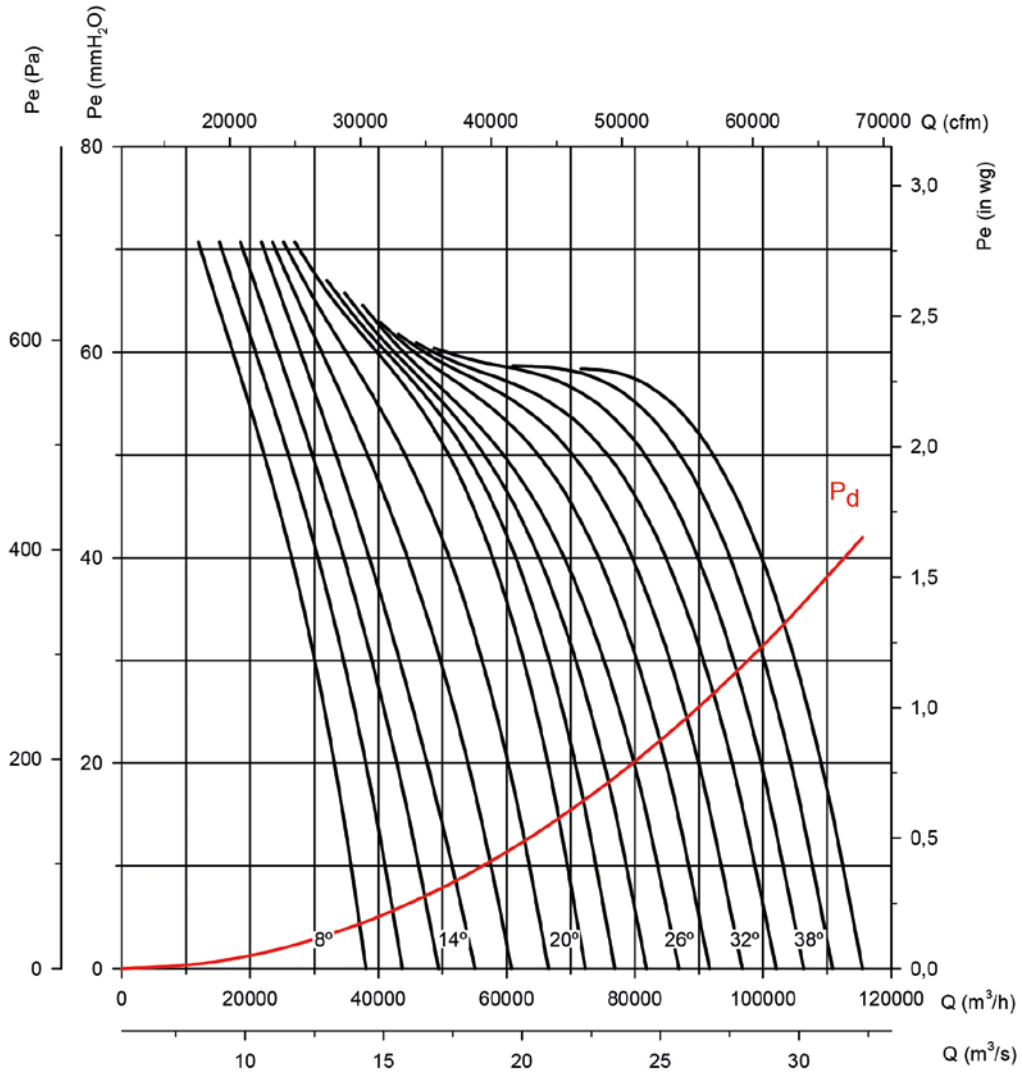

Potencia absorbida

Potencia motor recomendada kW (CV)

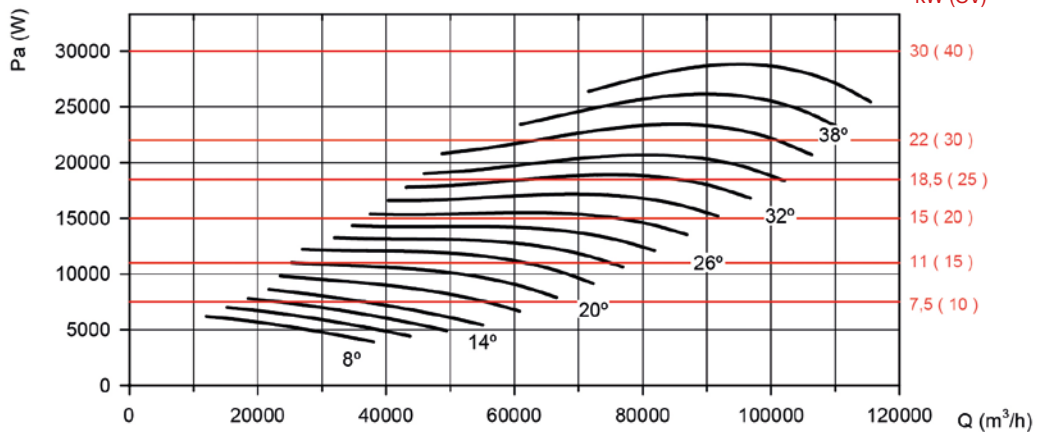

Curvas características

Q= Caudal en m³/h, m³/s y cfm

Pe= Presión estática en mmH₂O, Pa e inwg

Diámetro hélice en cm: 140

Número de polos motor: 6

Número de palas: 6

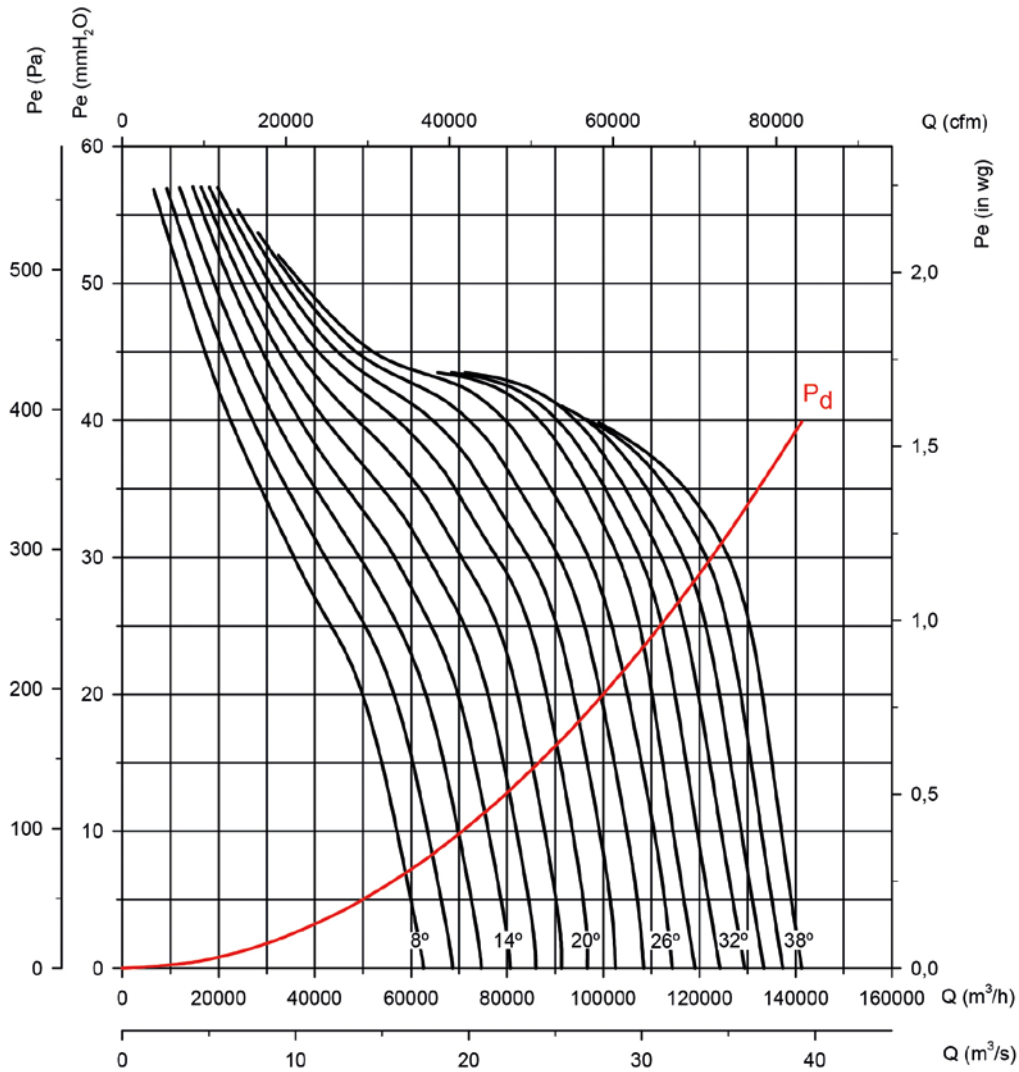

Potencia absorbida

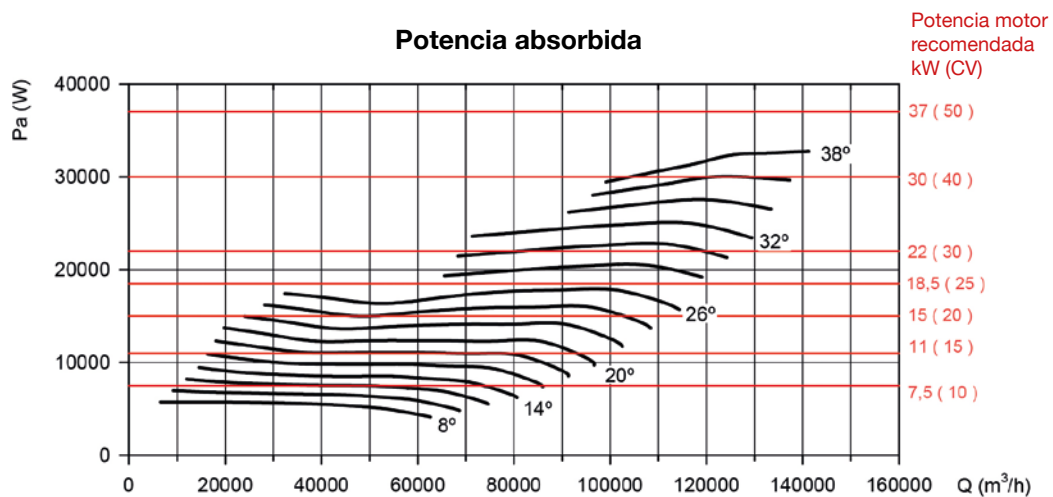

Curvas características

Q= Caudal en m³/h, m³/s y cfm

Pe= Presión estática en mmH₂O, Pa e inwg

Diámetro hélice en cm: 140

Número de polos motor: 6

Número de palas: 9

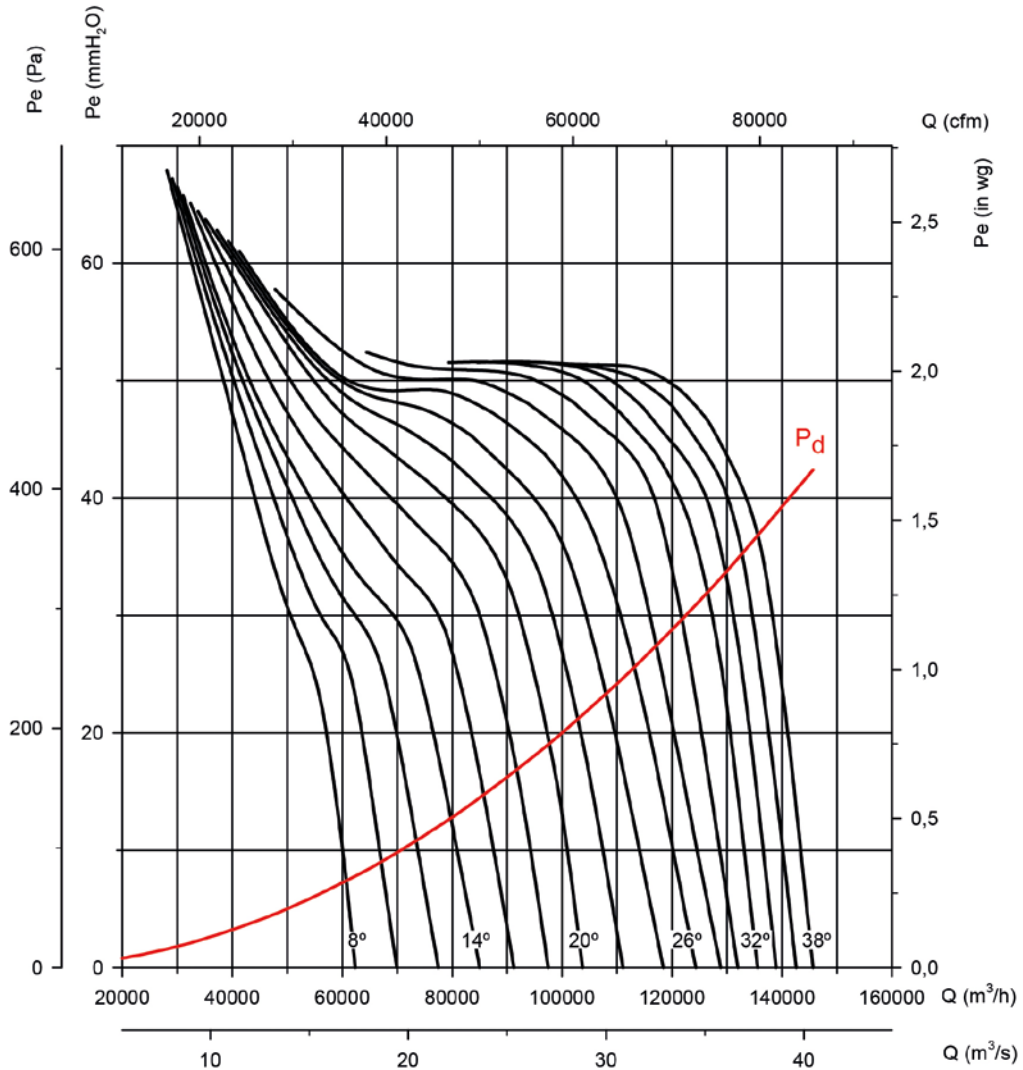

Potencia absorbida

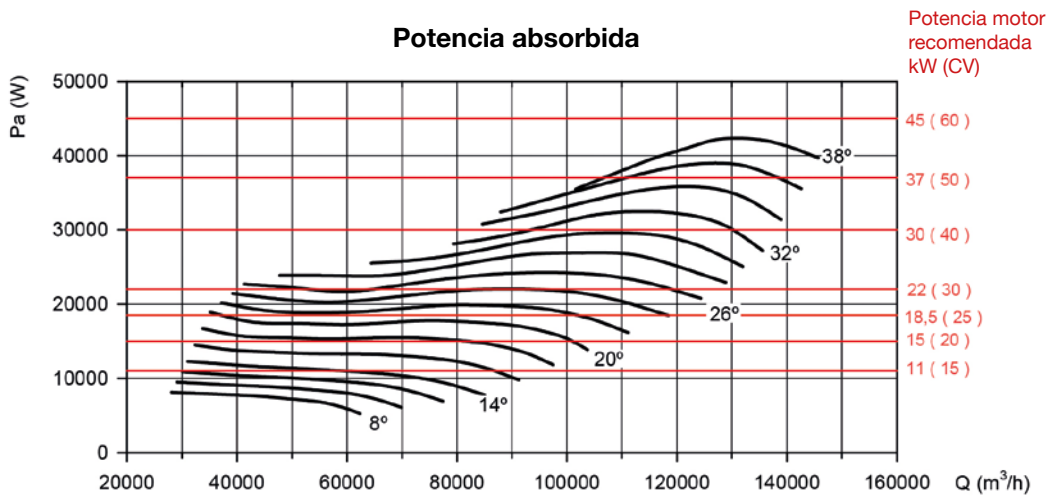

Curvas características

Q= Caudal en m³/h, m³/s y cfm

Pe= Presión estática en mmH₂O, Pa e inwg

Diámetro hélice en cm: 140

Número de polos motor: 6

Número de palas: 12

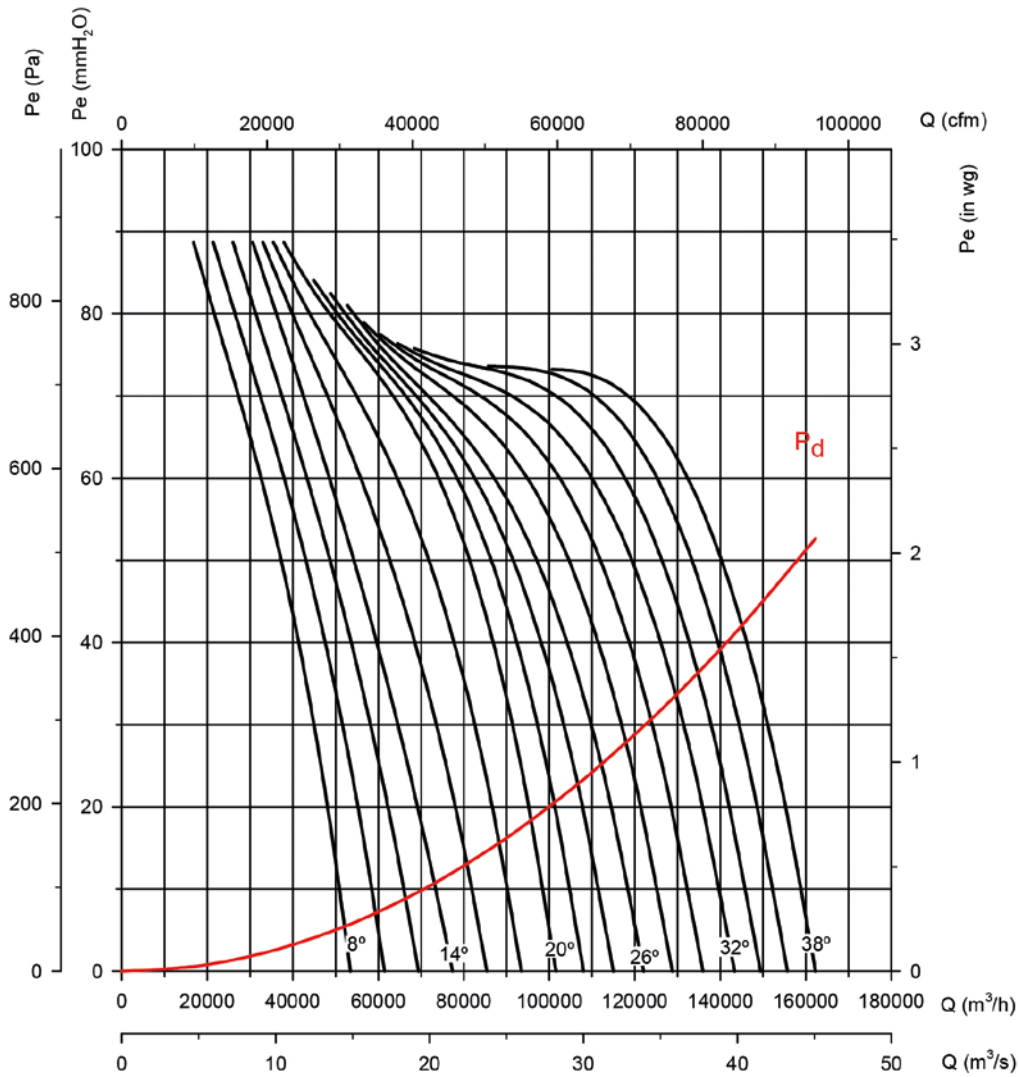

Potencia absorbida

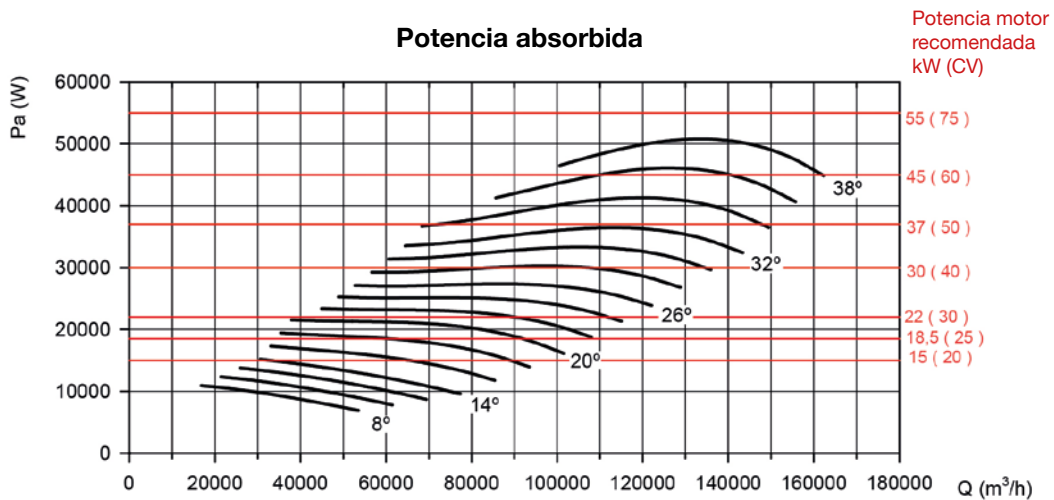

Curvas características

Q= Caudal en m³/h, m³/s y cfm

Pe= Presión estática en mmH₂O, Pa e inwg

Diámetro hélice en cm: 160

Número de polos motor: 6

Número de palas: 6

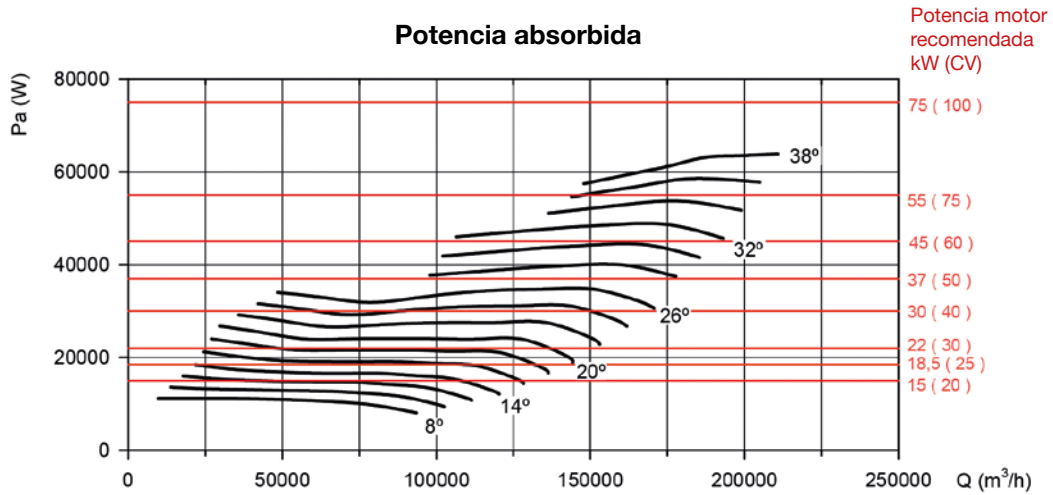
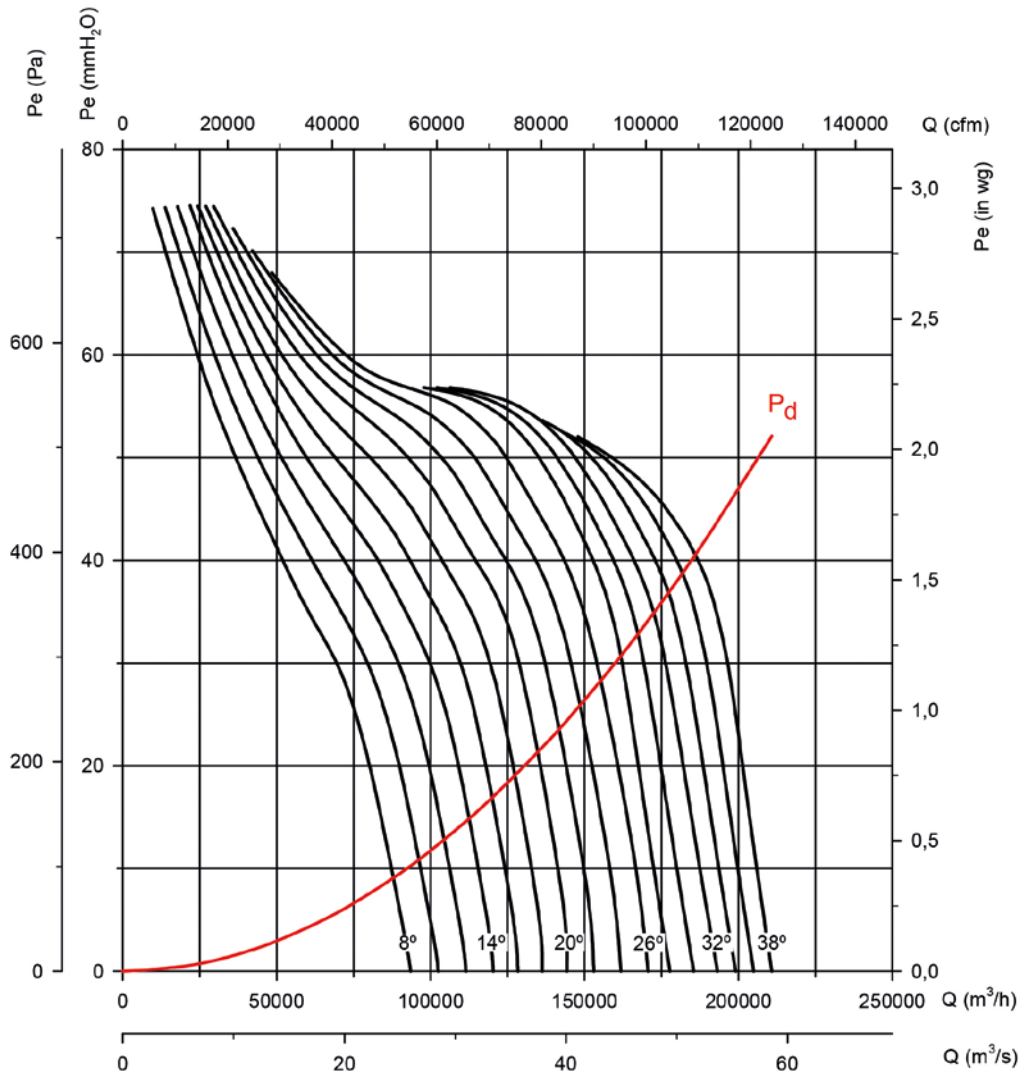

Curvas características

Q= Caudal en m³/h, m³/s y cfm

Pe= Presión estática en mmH₂O, Pa e inwg

Diámetro hélice en cm: 160

Número de polos motor: 6

Número de palas: 9

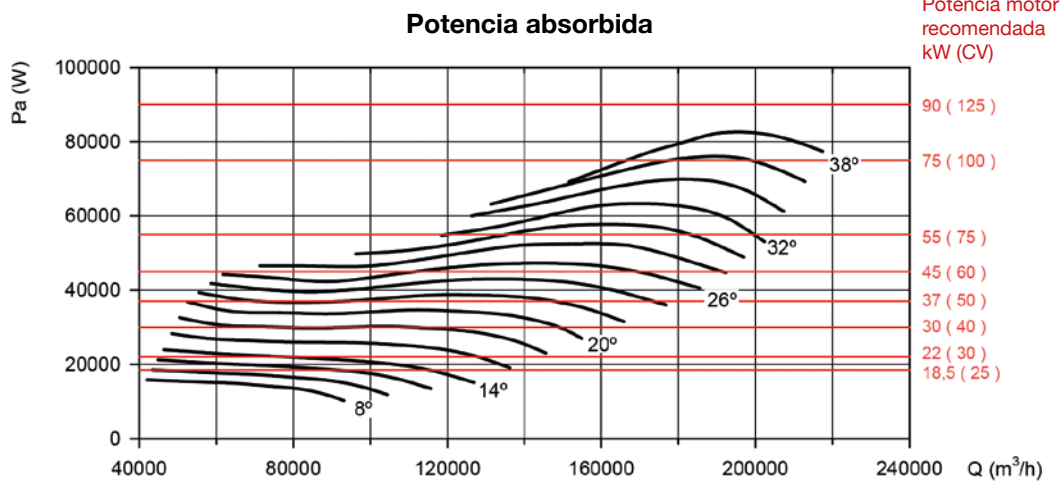
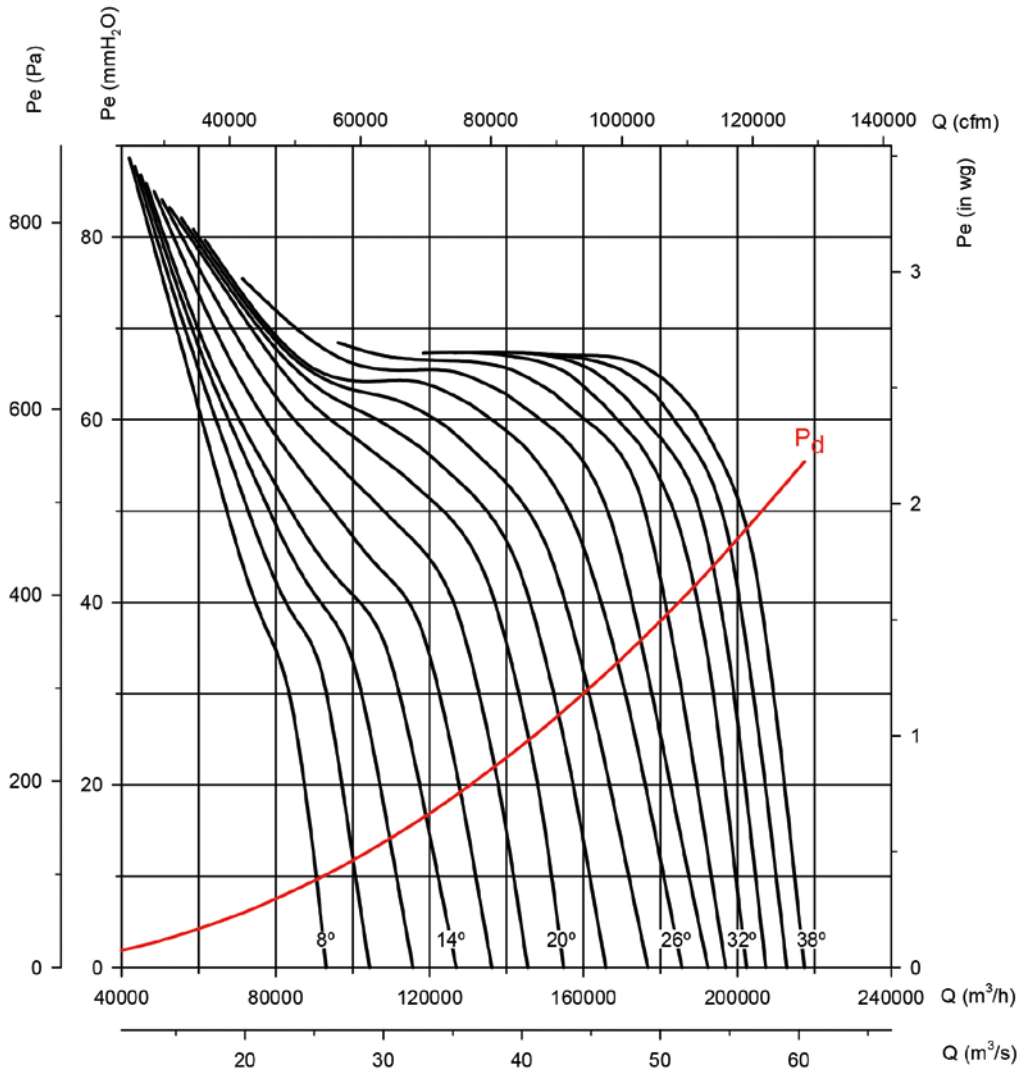

Curvas características

Q= Caudal en m³/h, m³/s y cfm

Pe= Presión estática en mmH₂O, Pa e inwg

Diámetro hélice en cm: 160

Número de polos motor: 6

Número de palas: 12

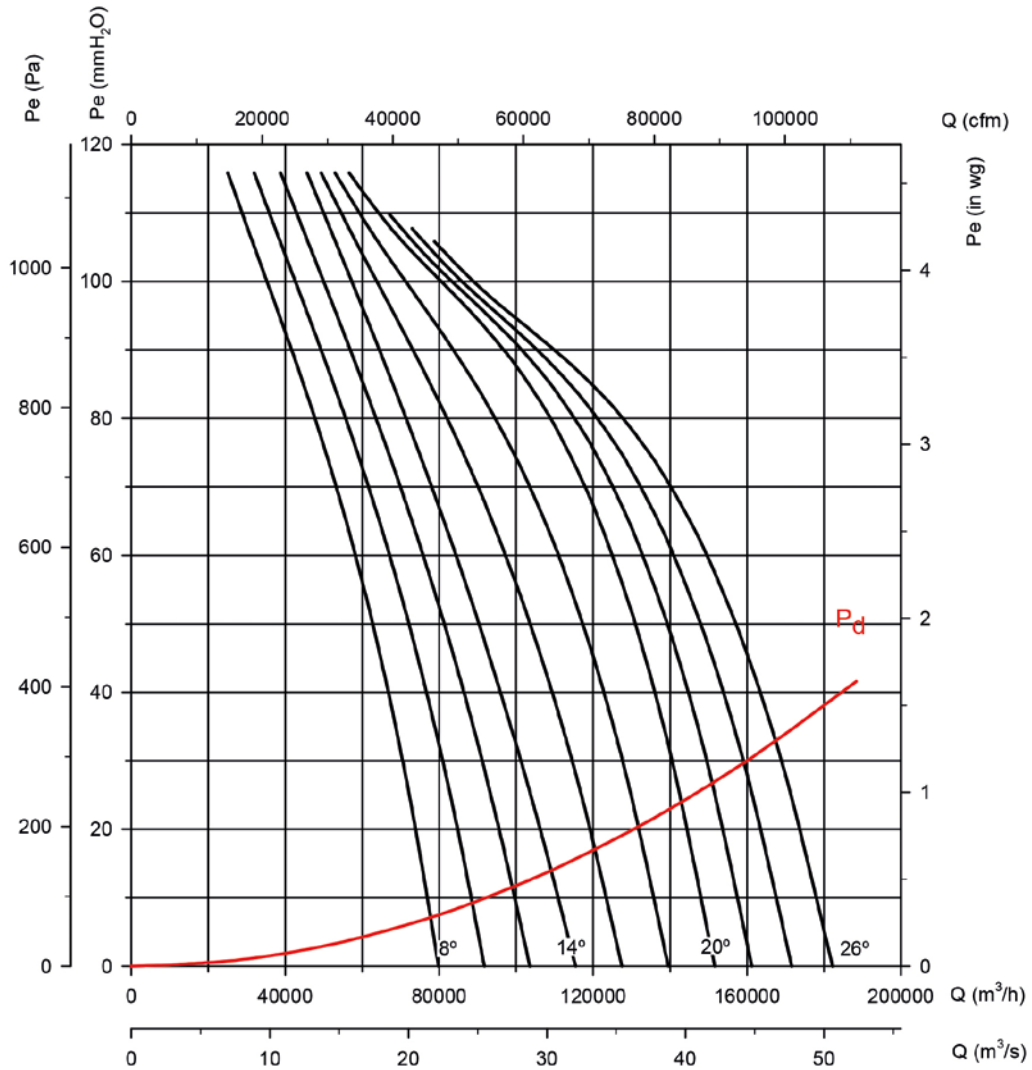

Potencia absorbida

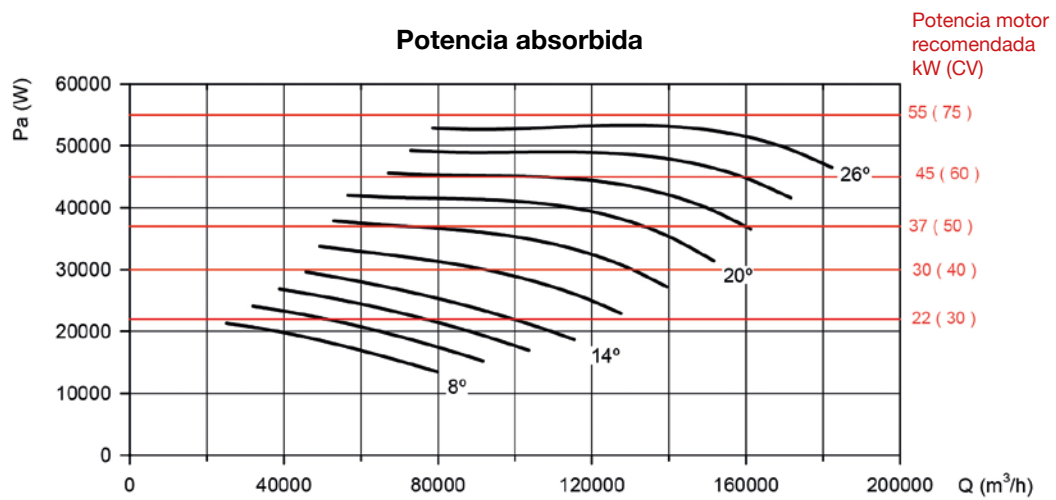

THT/CL



Extractores helicoidales tubulares con carcasa larga 400 °C/2h y 300 °C/2h, con caja de bornes exterior



Extractores helicoidales tubulares con carcasa larga para trabajar inmersos en zonas de riesgo de incendios.

Ventilador:

- Envoltente tubular en chapa de acero con caja de bornes exterior (Cable Box) y trampilla de inspección.
- Hélice de ángulo variable en fundición de aluminio.
- Homologación según norma EN 12101-3, con certificaciones n°: 0370-CPR-0305 (F400) y 0370-CPR-0973 (F300).
- Dirección aire motor-hélice.

Motor:

- Motores clase H para uso continuo S1 y uso emergencia S2. Con rodamientos a bolas, protección IP55 y 1 o 2 velocidades según modelo.
- Motores con eficiencia IE3 para potencias iguales o superiores a 0,75 kW, excepto monofásicos, 2 velocidades y 8 polos.
- Trifásico 230/400 V 50 Hz (hasta 3 kW) y 400/690 V 50 Hz (potencias superiores a 3 kW).

- Temperatura máxima del aire a transportar: Servicio S1 -20 °C +40 °C en continuo, apto también para climas cálidos con temperaturas hasta 50 °C. Servicio S2 300 °C/2h, 400 °C/2h.

Acabado:

- Anticorrosivo en resina de poliéster polimerizada a 190 °C, previo desengrase con tratamiento nanotecnológico libre de fosfatos.

Versiones disponibles:

- THT: ventiladores helicoidales tubulares con carcasa corta.

Bajo demanda:

- Dirección aire hélice-motor.
- Hélices reversibles 100%.

Código de pedido

De tamaño 40 a tamaño 100

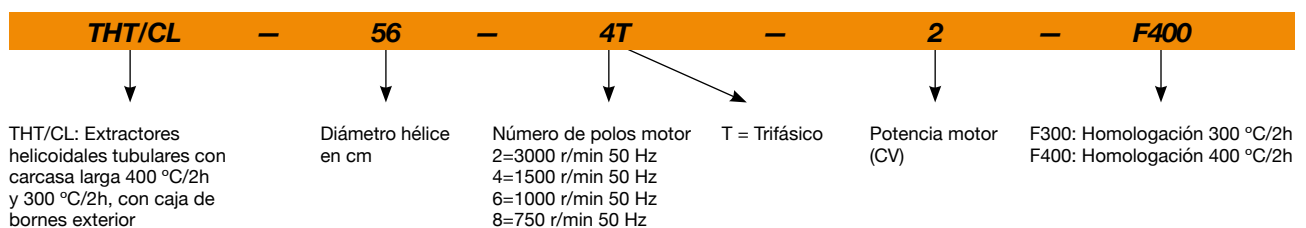

De tamaño 125 a tamaño 160

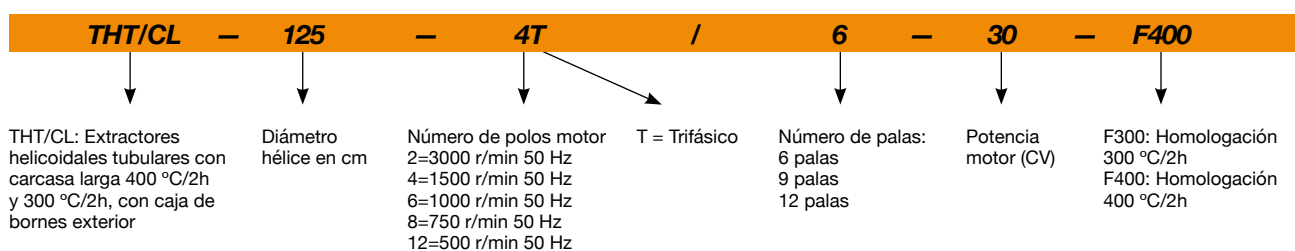

Características técnicas

Modelo	Velocidad (r/min)	Intensidad máxima admisible (A)			Potencia instalada (kW)	Ángulo inclinación palas (°)	Caudal máximo (m³/h)	Nivel presión sonora ¹ dB (A) Aspiración	Peso aprox. (Kg)
		230V	400V	690V					
THT/CL-40-2T-1.5 IE3	2880	3,93	2,26		1,10	20	7040	71	33
THT/CL-40-2/4T-1.5	2900 / 1435		2,89 / 1,04		1,10 / 0,25	20	7040 / 3480	71 / 56	34
THT/CL-40-2/4T-2	2940 / 1465		3,58 / 1,19		1,50 / 0,37	24	7950 / 3950	71 / 56	35
THT/CL-40-4T-0.75	1420	2,84	1,64		0,55	32	4800	55	32
THT/CL-40-6T-0.75	930	2,90	1,75		0,55	32	3150	46	37
THT/CL-40-6/12T-0.75	940 / 455		2,35 / 1,15		0,60 / 0,15	32	3150 / 1520	46 / 31	41
THT/CL-45-2T-2 IE3	2880	4,91	2,84		1,50	16	9400	71	38
THT/CL-45-2/4T-2	2940 / 1465		3,58 / 1,19		1,50 / 0,37	16	9400 / 4680	71 / 56	37
THT/CL-45-2T-3 IE3	2900	7,14	4,13		2,20	22	11330	71	39
THT/CL-45-2/4T-3	2930 / 1460		4,79 / 1,54		2,20 / 0,60	22	11330 / 5640	71 / 56	39
THT/CL-45-2T-4 IE3	2855	9,61	5,52		3,00	28	13074	72	49
THT/CL-45-4T-0.75	1420	2,84	1,64		0,55	36	7450	58	34
THT/CL-45-6T-0.75	930	2,90	1,75		0,55	30	4450	48	38
THT/CL-45-6/12T-0.75	940 / 455		2,35 / 1,15		0,60 / 0,15	30	4450 / 2150	48 / 33	42
THT/CL-50-2T-3 IE3	2860	7,14	4,13		2,20	12	11948	76	46
THT/CL-50-2/4T-4	2920 / 1445		6,70 / 2,09		3,00 / 0,80	16	13880 / 6870	76 / 61	51
THT/CL-50-2/4T-6	2930 / 1455		9,50 / 2,80		4,50 / 1,30	20	15900 / 7880	76 / 61	67
THT/CL-50-4T-0.75	1420	2,84	1,64		0,55	22	8390	60	35
THT/CL-50-6T-0.75	930	2,90	1,75		0,55	32	7000	52	40
THT/CL-56-2T-5.5 IE3	2890		7,20	4,17	4,00	16	18800	78	69
THT/CL-56-2/4T-6	2930 / 1455		9,50 / 2,80		4,50 / 1,30	16	18800 / 9320	78 / 63	71
THT/CL-56-2/4T-12	2920 / 1440		18,30 / 5,90		9,00 / 2,50	30	27200 / 13390	79 / 64	137
THT/CL-56-4T-1 IE3	1430	3,08	1,79		0,75	22	11250	63	45
THT/CL-56-4T-1.5 IE3	1440	4,10	2,37		1,10	30	13600	63	44
THT/CL-56-4/8T-1.5	1440 / 705		2,69 / 1,12		1,10 / 0,25	30	13600 / 6640	63 / 48	48
THT/CL-56-4T-2 IE3	1415	5,89	3,38		1,50	36	15030	64	48
THT/CL-56-6T-0.75	930	2,90	1,75		0,55	38	10140	54	44
THT/CL-56-6/12T-0.75	940 / 455		2,35 / 1,15		0,60 / 0,15	38	10140 / 4890	54 / 39	48
THT/CL-63-2T-12 IE3	2950		18,07	10,44	9,20	18	32300	83	161
THT/CL-63-2T-20 IE3	2960		26,50	15,35	15,00	28	39950	82	188
THT/CL-63-4T-1 IE3	1430	3,08	1,79		0,75	14	15190	67	49
THT/CL-63-4T-1.5 IE3	1420	4,10	2,37		1,10	20	17800	66	51
THT/CL-63-4/8T-1.5	1440 / 705		2,69 / 1,12		1,10 / 0,25	20	17800 / 8680	66 / 51	55
THT/CL-63-4T-2 IE3	1425	5,89	3,38		1,50	24	19280	66	55
THT/CL-63-4/8T-2	1415 / 715		3,40 / 1,65		1,50 / 0,30	24	19280 / 9740	66 / 52	70
THT/CL-63-4T-3 IE3	1435	7,86	4,52		2,20	32	22150	68	64
THT/CL-63-4/8T-3	1415 / 700		4,80 / 1,85		2,20 / 0,45	32	22150 / 10920	68 / 53	77
THT/CL-63-4T-4 IE3	1430	11,01	6,33		3,00	38	24240	69	73
THT/CL-63-4/8T-4	1420 / 710		6,45 / 2,28		3,00 / 0,60	38	24240 / 12070	69 / 54	86
THT/CL-63-6T-0.75	930	2,90	1,75		0,55	28	13590	57	51
THT/CL-63-6/12T-0.75	940 / 455		2,35 / 1,15		0,60 / 0,15	28	13590 / 6550	57 / 42	55
THT/CL-63-6T-1 IE3	940	3,36	1,93		0,75	38	15890	58	54
THT/CL-63-6/12T-1	935 / 455		3,75 / 2,76		0,80 / 0,20	38	15890 / 7700	58 / 43	61
THT/CL-71-4T-1.5 IE3	1420	4,10	2,37		1,10	12	19480	71	58
THT/CL-71-4/8T-1.5	1440 / 705		2,69 / 1,12		1,10 / 0,25	12	19480 / 9500	71 / 56	61
THT/CL-71-4T-2 IE3	1425	5,89	3,38		1,50	14	20900	70	61
THT/CL-71-4/8T-2	1415 / 715		3,40 / 1,65		1,50 / 0,30	14	20900 / 10560	70 / 56	76
THT/CL-71-4T-3 IE3	1435	7,86	4,52		2,20	22	25100	70	70
THT/CL-71-4/8T-3	1415 / 700		4,80 / 1,85		2,20 / 0,45	22	25100 / 12370	70 / 55	82
THT/CL-71-4T-4 IE3	1430	11,01	6,33		3,00	28	27480	70	79
THT/CL-71-4/8T-4	1420 / 710		6,45 / 2,28		3,00 / 0,60	28	27480 / 13680	70 / 55	92
THT/CL-71-6T-0.75	930	2,90	1,75		0,55	20	16100	60	57
THT/CL-71-6/12T-0.75	940 / 455		2,35 / 1,15		0,60 / 0,15	20	16100 / 7760	60 / 45	61
THT/CL-71-6T-1 IE3	940	3,36	1,93		0,75	26	17300	60	61
THT/CL-71-6/12T-1	935 / 455		3,75 / 2,76		0,80 / 0,20	26	17300 / 8380	60 / 45	67

Características técnicas

Modelo	Velocidad (r/min)	Intensidad máxima admisible (A)			Potencia instalada (kW)	Ángulo inclinación palas (°)	Caudal máximo (m³/h)	Nivel presión sonora¹ dB (A) Aspiración	Peso aprox. (Kg)
		230V	400V	690V					
THT/CL-71-6T-1.5 IE3	945	4,73	2,72		1,10	34	19930	61	69
THT/CL-71-6/12T-1.5	940 / 460		3,52 / 2,00		1,20 / 0,30	34	19930 / 9760	61 / 46	77
THT/CL-80-4T-3 IE3	1435	7,86	4,52		2,20	12	25450	75	79
THT/CL-80-4/8T-3	1415 / 670		4,80 / 1,85		2,20 / 0,45	12	25450 / 12550	75 / 60	91
THT/CL-80-4T-4 IE3	1430	11,01	6,33		3,00	16	30250	74	88
THT/CL-80-4/8T-4	1420 / 710		6,45 / 2,28		3,00 / 0,60	16	30250 / 15060	74 / 59	101
THT/CL-80-4T-5.5 IE3	1440		7,95	4,61	4,00	18	32750	73	94
THT/CL-80-4/8T-5.5	1450 / 715		7,88 / 2,87		3,80 / 1,00	18	32750 / 16150	73 / 58	127
THT/CL-80-6T-1.5 IE3	945	4,73	2,72		1,10	18	21450	63	78
THT/CL-80-6/12T-1.5	940 / 460		3,52 / 2,00		1,20 / 0,30	18	21450 / 10500	63 / 48	86
THT/CL-80-6T-2 IE3	945	6,25	3,62		1,50	26	25950	64	87
THT/CL-80-6/12T-2	960 / 470		4,46 / 3,43		1,60 / 0,40	26	25950 / 12700	64 / 49	91
THT/CL-80-6T-3 IE3	950	9,78	5,62		2,20	32	29930	65	94
THT/CL-80-6/12T-3	940 / 475		5,62 / 3,32		2,20 / 0,55	32	29930 / 15120	65 / 51	100
THT/CL-80-8T-0.75	700	3,48	2,00		0,55	20	17540	57	71
THT/CL-80-8T-1	710	5,06	2,92		0,75	28	20650	58	78
THT/CL-90-4T-4 IE3	1430	11,01	6,33		3,00	8	33580	79	110
THT/CL-90-4/8T-4	1420 / 710		6,45 / 2,28		3,00 / 0,60	8	33580 / 16720	79 / 64	124
THT/CL-90-4T-5.5 IE3	1440		7,95	4,61	4,00	12	38890	78	117
THT/CL-90-4/8T-5.5	1450 / 715		7,88 / 2,87		3,80 / 1,00	12	38890 / 19170	78 / 63	150
THT/CL-90-4T-7.5 IE3	1430		10,40	6,04	5,50	18	46140	77	143
THT/CL-90-4/8T-7.5	1455 / 725		11,40 / 3,86		5,50 / 1,10	18	46140 / 22910	77 / 62	157
THT/CL-90-4T-10 IE3	1460		14,20	8,17	7,50	22	50140	76	154
THT/CL-90-4/8T-10	1455 / 725		15,10 / 5,16		7,50 / 1,50	22	50140 / 24900	76 / 61	157
THT/CL-90-6T-2 IE3	945	6,25	3,62		1,50	16	28780	66	110
THT/CL-90-6/12T-2	960 / 470		4,46 / 3,43		1,60 / 0,40	16	28780 / 14090	66 / 51	114
THT/CL-90-6T-3 IE3	950	9,78	5,62		2,20	24	34000	66	116
THT/CL-90-6/12T-3	940 / 475		5,62 / 3,32		2,20 / 0,55	24	34000 / 17180	66 / 52	123
THT/CL-90-6T-4 IE3	945	12,80	6,36		3,00	30	38900	69	142
THT/CL-90-6/12T-4	970 / 485		7,37 / 3,53		2,80 / 0,70	30	38900 / 19450	69 / 54	143
THT/CL-90-8T-1	710	5,06	2,92		0,75	18	22900	60	100
THT/CL-90-8T-2	700	7,32	4,21		1,50	30	29490	63	116
THT/CL-90-8T-3	705	9,30	5,35		2,20	32	30850	64	134
THT/CL-100-4T-7.5 IE3	1430		10,40	6,04	5,50	10	46850	82	151
THT/CL-100-4/8T-7.5	1455 / 725		11,40 / 3,86		5,50 / 1,10	10	46850 / 23260	82 / 67	165
THT/CL-100-4T-10 IE3	1460		14,20	8,17	7,50	16	57400	79	162
THT/CL-100-4/8T-10	1455 / 725		15,10 / 5,16		7,50 / 1,50	14	54710 / 27170	80 / 65	165
THT/CL-100-4T-15 IE3	1455		20,70	11,99	11,00	22	66300	79	215
THT/CL-100-4/8T-15	1470 / 730		20,70 / 7,19		11,00 / 3,00	22	66300 / 32880	79 / 64	215
THT/CL-100-4T-20 IE3	1460		27,80	16,03	15,00	28	76150	80	230
THT/CL-100-4/8T-20	1470 / 725		31,72 / 11,75		15,00 / 3,80	28	76150 / 37560	80 / 65	230
THT/CL-100-4T/9-15 IE3	1460		20,70	11,99	11,00	18	55340	80	224
THT/CL-100-4T/9-20 IE3	1460		27,80	16,03	15,00	22	63260	80	239
THT/CL-100-4T/9-25 IE3	1475		35,40	20,39	18,50	26	70625	80	269
THT/CL-100-4T/9-30 IE3	1475		42,20	24,44	22,00	30	74845	82	286
THT/CL-100-6T-3 IE3	950	9,78	5,62		2,20	16	37600	70	124
THT/CL-100-6/12T-3	940 / 475		5,62 / 3,32		2,20 / 0,55	16	37600 / 18990	70 / 56	130
THT/CL-100-6T-4 IE3	945	12,80	6,36		3,00	20	41150	69	150
THT/CL-100-6/12T-4	970 / 485		7,37 / 3,53		2,80 / 0,70	20	41150 / 20580	69 / 54	151
THT/CL-100-6T-5.5 IE3	970		8,37	4,82	4,00	26	47780	70	162
THT/CL-100-6T/9-5.5 IE3	970		11,00	6,35	4,00	20	39020	70	165
THT/CL-100-6T/9-7.5 IE3	970		12,30	7,07	5,50	26	46765	71	173
THT/CL-100-6T/9-10 IE3	970		15,20	8,83	7,50	34	52255	74	213
THT/CL-125-4T/6-20 IE3	1460		27,80	16,03	15,00	10	78600	87	318
THT/CL-125-4/8T/6-20	1470 / 725		31,72 / 11,75		15,00 / 3,80	10	78600 / 38770	87 / 72	318

Características técnicas

Modelo	Velocidad (r/min)	Intensidad máxima admisible (A)			Potencia instalada (kW)	Ángulo inclinación palas (°)	Caudal máximo (m³/h)	Nivel presión sonora ¹ dB (A) Aspiración	Peso aprox. (Kg)
		230V	400V	690V					
THT/CL-125-4T/6-25 IE3	1465		35,40	20,39	18,50	14	92550	86	386
THT/CL-125-4/8T/6-27	1470 / 730		39,70 / 14,10		20,00 / 5,00	16	98830 / 48910	85 / 70	400
THT/CL-125-4T/6-30 IE3	1470		42,20	24,44	22,00	16	98830	85	400
THT/CL-125-4/8T/6-37	1475 / 735		54,55 / 18,50		28,00 / 6,50	20	110890 / 55260	85 / 70	481
THT/CL-125-4T/6-40 IE3	1475		53,30	31,02	30,00	22	117450	85	481
THT/CL-125-4T/6-50 IE3	1480		66,80	38,70	37,00	26	131050	85	529
THT/CL-125-4T/6-60 IE3	1475		80,90	46,90	45,00	28	135820	85	599
THT/CL-125-4T/6-75 IE3	1480		98,60	57,20	55,00	34	152100	88	699
THT/CL-125-4T/9-25 IE3	1465		35,40	20,39	18,50	10	79650	87	395
THT/CL-125-4T/9-30 IE3	1470		42,20	24,44	22,00	12	88290	86	409
THT/CL-125-4/8T/9-27	1470 / 730		39,70 / 14,10		20,00 / 5,00	12	88290 / 43690	86 / 71	409
THT/CL-125-4/8T/9-37	1475 / 735		54,55 / 18,50		28,00 / 6,50	16	104040 / 51840	85 / 70	490
THT/CL-125-4T/9-40 IE3	1475		53,30	31,02	30,00	16	104040	85	490
THT/CL-125-4T/9-50 IE3	1480		66,80	38,70	37,00	20	118400	85	538
THT/CL-125-4T/9-60 IE3	1475		80,90	46,90	45,00	24	134970	85	590
THT/CL-125-4T/9-75 IE3	1480		98,60	57,20	55,00	28	146770	86	690
THT/CL-125-4T/9-100 IE3	1480		128,00	74,22	75,00	34	158560	88	829
THT/CL-125-4T/12-50 IE3	1480		66,80	38,70	37,00	18	101660	86	560
THT/CL-125-4T/12-60 IE3	1475		80,90	46,90	45,00	20	109180	86	605
THT/CL-125-4T/12-75 IE3	1480		98,60	57,20	55,00	26	131240	86	705
THT/CL-125-4T/12-100 IE3	1480		128,00	74,22	75,00	32	154100	88	835
THT/CL-125-6T/6-5.5 IE3	970		8,37	4,82	4,00	10	51500	77	251
THT/CL-125-6T/6-7.5 IE3	970		12,30	7,07	5,50	14	60640	75	258
THT/CL-125-6/12T/6-7.5	970 / 480		14,50 / 5,17		5,50 / 1,00	14	60640 / 30010	75 / 60	272
THT/CL-125-6T/6-10 IE3	960		15,20	8,83	7,50	20	72650	74	283
THT/CL-125-6/12T/6-10	970 / 490		13,60 / 5,69		7,20 / 1,80	20	72650 / 36510	74 / 60	303
THT/CL-125-6T/6-15 IE3	955		22,50	13,07	11,00	26	85850	74	313
THT/CL-125-6/12T/6-15	970 / 485		23,10 / 8,41		11,00 / 3,00	26	85850 / 42710	74 / 59	318
THT/CL-125-6T/6-20 IE3	950		29,00	16,78	15,00	30	92850	76	386
THT/CL-125-6/12T/6-24	970 / 480		41,60 / 13,21		17,60 / 2,85	34	99650 / 49320	78 / 63	481
THT/CL-125-6T/9-10 IE3	960		15,20	8,83	7,50	14	63490	77	292
THT/CL-125-6/12T/9-10	970 / 490		13,60 / 5,69		7,20 / 1,80	14	63490 / 31910	77 / 63	312
THT/CL-125-6T/9-15 IE3	955		22,50	13,07	11,00	20	77550	75	322
THT/CL-125-6/12T/9-15	970 / 485		23,10 / 8,41		11,00 / 3,00	20	77550 / 38580	75 / 60	327
THT/CL-125-6T/9-20 IE3	950		29,00	16,78	15,00	26	92950	75	395
THT/CL-125-6/12T/9-24	970 / 480		41,60 / 13,21		17,60 / 2,85	30	98500 / 48750	76 / 61	490
THT/CL-125-6T/9-25 IE3	975		36,10	20,77	18,50	32	101450	77	416
THT/CL-125-6T/9-30 IE3	975		42,30	24,35	22,00	36	106525	80	426
THT/CL-125-6T/12-10 IE3	970		15,20	8,83	7,50	12	49630	79	372
THT/CL-125-6T/12-15 IE3	970		22,50	13,07	11,00	18	67315	77	382
THT/CL-125-6T/12-20 IE3	970		29,00	16,78	15,00	24	81840	76	440
THT/CL-125-6T/12-25 IE3	975		36,10	20,77	18,50	30	96765	77	450
THT/CL-125-6T/12-30 IE3	975		42,30	24,35	22,00	32	102040	78	460
THT/CL-125-6T/12-40 IE3	985		56,00	32,50	30,00	34	106355	79	615
THT/CL-140-6T/6-7.5 IE3	970		12,30	7,07	5,50	8	62800	83	297
THT/CL-140-6T/6-15 IE3	955		22,50	13,07	11,00	16	86640	78	366
THT/CL-140-6T/6-20 IE3	950		29,00	16,78	15,00	22	102950	77	445
THT/CL-140-6T/6-25 IE3	975		36,10	20,77	18,50	24	108750	77	497
THT/CL-140-6T/6-30 IE3	975		42,30	24,35	22,00	28	119050	77	506
THT/CL-140-6T/9-15 IE3	955		22,50	13,07	11,00	12	77400	82	375
THT/CL-140-6T/9-20 IE3	950		29,00	16,78	15,00	16	91200	81	455
THT/CL-140-6T/9-25 IE3	975		36,10	20,77	18,50	20	103800	80	506
THT/CL-140-6T/9-30 IE3	975		42,30	24,35	22,00	22	111000	79	515
THT/CL-140-6T/9-40 IE3	985		56,00	32,50	30,00	28	128800	79	673
THT/CL-140-6T/9-50 IE3	980		67,20	39,00	37,00	32	135750	80	751

Características técnicas

Modelo	Velocidad (r/min)	Intensidad máxima admisible (A)			Potencia instalada (kW)	Ángulo inclinación palas (°)	Caudal máximo (m³/h)	Nivel presión sonora¹ dB (A) Aspiración	Peso aprox. (Kg)
		230V	400V	690V					
THT/CL-140-6T/9-60 IE3	985		84,40	48,90	45,00	38	145610	82	986
THT/CL-140-6T/12-30 IE3	975		42,30	24,35	22,00	20	101570	81	531
THT/CL-140-6T/12-40 IE3	985		56,00	32,50	30,00	28	128800	80	686
THT/CL-140-6T/12-50 IE3	985		67,20	39,00	37,00	32	143360	81	769
THT/CL-140-6T/12-60 IE3	985		84,40	48,90	45,00	36	156705	82	979
THT/CL-140-6T/12-75 IE3	985		103,00	59,70	55,00	38	162890	83	1004
THT/CL-160-6T/6-20 IE3	950		29,00	16,78	15,00	12	111990	85	532
THT/CL-160-6T/6-25 IE3	975		36,10	20,77	18,50	14	121100	84	584
THT/CL-160-6T/6-30 IE3	975		42,30	24,35	22,00	16	129330	83	593
THT/CL-160-6T/6-40 IE3	985		56,00	32,50	30,00	22	153700	82	768
THT/CL-160-6T/6-50 IE3	980		67,20	39,00	37,00	26	170800	81	842
THT/CL-160-6T/6-60 IE3	985		84,40	48,90	45,00	30	185460	82	1064
THT/CL-160-6T/6-75 IE3	985		103,00	59,70	55,00	34	199030	83	1109
THT/CL-160-6T/9-25 IE3	975		36,10	20,77	18,50	10	104250	90	594
THT/CL-160-6T/9-30 IE3	975		42,30	24,35	22,00	14	126800	88	603
THT/CL-160-6T/9-40 IE3	985		56,00	32,50	30,00	18	145500	86	778
THT/CL-160-6T/9-50 IE3	980		67,20	39,00	37,00	20	154940	85	852
THT/CL-160-6T/9-60 IE3	985		84,40	48,90	45,00	24	176750	85	1067
THT/CL-160-6T/9-75 IE3	985		103,00	59,70	55,00	28	192290	84	1112
THT/CL-160-6T/12-60 IE3	985		84,40	48,90	45,00	20	151615	86	1071
THT/CL-160-6T/12-75 IE3	985		103,00	59,70	55,00	26	182250	85	1116

1 Los valores de los niveles sonoros, son presiones en dB(A) medidos a 3 metros, en campo libre.



Erp. (Energy Related Products)

Información de la Directiva 2009/125/EC descargable desde la web de SODECA o programa de selección QuickFan.

Características acústicas

Espectro de potencia sonora Lw(A) en dB(A) por banda de frecuencia en Hz
Valores tomados a la aspiración con caudal máximo

	63	125	250	500	1000	2000	4000	8000		63	125	250	500	1000	2000	4000	8000
40-2-1.5	47	63	75	83	88	86	82	75	56-4-12 (2V)	39	52	70	78	80	79	74	67
40-4-1.5 (2V)	32	48	60	68	73	71	67	60	56-4-1	51	63	72	78	78	78	72	64
40-2-2	47	63	75	83	88	86	82	75	56-4-1.5	51	63	72	78	78	78	72	64
40-4-2 (2V)	32	48	60	68	73	71	67	60	56-8-1.5 (2V)	35	47	56	62	62	62	56	48
40-4-0.75	37	53	63	70	71	68	67	68	56-4-2	52	64	73	79	79	79	73	65
40-6-0.75	28	44	54	61	62	59	58	59	56-6-0.75	45	55	65	69	70	68	61	53
40-12-0.75 (2V)	12	28	38	45	46	43	42	43	56-12-0.75 (2V)	29	39	49	53	54	52	45	37
45-2-2	47	60	74	86	87	86	82	74	63-2-12	64	81	91	97	98	97	95	97
45-4-2 (2V)	32	45	59	71	72	71	67	59	63-2-20	63	80	90	96	97	96	94	96
45-2-3	47	64	74	81	88	86	83	75	63-4-1	48	64	76	82	84	81	74	66
45-4-3 (2V)	32	49	59	66	73	71	68	60	63-4-1.5	47	63	75	81	83	80	73	65
45-2-4	52	69	78	84	88	88	83	75	63-8-1.5 (2V)	31	47	59	65	67	64	57	49
45-4-0.75	47	59	67	73	73	73	68	60	63-4-2	54	66	75	81	81	81	75	67
45-6-0.75	37	49	57	63	63	63	58	50	63-8-2 (2V)	39	51	60	66	66	66	60	52
45-12-0.75 (2V)	21	33	41	47	47	47	42	34	63-4-3	56	68	77	83	83	83	77	69
50-2-3	58	74	84	91	92	89	88	89	63-8-3 (2V)	41	53	62	68	68	68	62	54
50-2-4	58	74	84	91	92	89	88	89	63-4-4	57	69	78	84	84	84	78	70
50-4-4 (2V)	43	59	69	76	77	74	73	74	63-8-4 (2V)	42	54	63	69	69	69	63	55
50-2-6	58	74	84	91	92	89	88	89	63-6-0.75	48	58	68	72	73	71	64	56
50-4-6 (2V)	43	59	69	76	77	74	73	74	63-12-0.75 (2V)	32	42	52	56	57	55	48	40
50-4-0.75	49	61	69	75	75	75	70	62	63-6-1	49	59	69	73	74	72	65	57
50-6-0.75	41	53	61	67	67	67	62	54	63-12-1 (2V)	32	42	52	56	57	55	48	40
56-2-5.5	53	66	84	92	94	93	88	81	71-4-1.5	57	73	80	86	86	86	82	74
56-2-6	53	66	84	92	94	93	88	81	71-8-1.5 (2V)	41	57	64	70	70	70	66	58
56-4-6 (2V)	38	51	69	77	79	78	73	66	71-4-2	56	72	79	85	85	85	81	73
56-2-12	54	67	85	93	95	94	89	82	71-8-2 (2V)	41	57	64	70	70	70	66	58

Características acústicas

Espectro de potencia sonora Lw(A) en dB(A) por banda de frecuencia en Hz
Valores tomados a la aspiración con caudal máximo

	63	125	250	500	1000	2000	4000	8000		63	125	250	500	1000	2000	4000	8000
71-4-3	56	72	79	85	85	85	81	73	125-4/9-25	67	81	94	102	104	101	96	88
71-8-3 (2V)	41	57	64	70	70	70	66	58	125-4/9-27	66	80	93	101	103	100	95	87
71-4-4	63	75	79	85	85	86	83	75	125-8/9-27 (2V)	51	65	78	86	88	85	80	72
71-8-4 (2V)	48	60	64	70	70	71	68	60	125-4/9-30	66	80	93	101	103	100	95	87
71-6-0.75	46	53	73	76	76	71	63	55	125-4/9-37	65	79	92	100	102	99	94	86
71-12-0.75 (2V)	30	37	57	60	60	55	47	39	125-8/9-37 (2V)	50	64	77	85	87	84	79	71
71-6-1	46	64	73	76	76	71	64	55	125-4/9-40	65	79	92	100	102	99	94	86
71-12-1 (2V)	29	47	56	59	59	54	47	38	125-4/9-50	65	79	92	100	102	99	94	86
71-6-1.5	47	65	74	77	77	72	65	56	125-4/9-60	73	86	95	99	101	100	96	89
71-12-1.5 (2V)	32	50	59	62	62	57	50	41	125-4/9-75	74	87	96	100	102	101	97	90
80-4-3	55	71	84	91	91	88	82	74	125-4/9-100	76	89	98	102	104	103	99	92
80-8-3 (2V)	40	56	69	76	76	73	67	59	125-4/12-50	66	80	93	101	103	100	95	87
80-4-4	54	70	83	90	90	87	81	73	125-4/12-60	66	80	93	101	103	100	95	87
80-8-4 (2V)	39	55	68	75	75	72	66	58	125-4/12-75	74	87	96	100	102	101	97	90
80-4-5.5	53	69	82	89	89	86	80	72	125-4/12-100	76	89	98	102	104	103	99	92
80-8-5.5 (2V)	38	54	67	74	74	71	65	57	125-6/6-5.5	64	79	89	92	93	90	85	77
80-6-1.5	53	68	75	78	79	76	70	62	125-6/6-7.5	62	77	87	90	91	88	83	75
80-12-1.5 (2V)	38	53	60	63	64	61	55	47	125-12/6-7.5 (2V)	47	62	72	75	76	73	68	60
80-6-2	59	69	75	79	80	78	73	65	125-6/6-10	61	76	86	89	90	87	82	74
80-12-2 (2V)	43	53	59	63	64	62	57	49	125-12/6-10 (2V)	46	61	71	74	75	72	67	59
80-6-3	60	70	76	80	81	79	74	66	125-6/6-15	61	76	86	89	90	87	82	74
80-12-3 (2V)	45	55	61	65	66	64	59	51	125-12/6-15 (2V)	45	60	70	73	74	71	66	58
80-8-0.75	46	59	67	72	74	71	64	53	125-6/6-20	63	78	88	91	92	89	84	76
80-8-1	47	60	68	73	75	72	65	54	125-6/6-24	65	80	90	93	94	91	86	78
90-4-4	61	77	88	94	95	93	88	80	125-12/6-24 (2V)	50	65	75	78	79	76	71	63
90-8-4 (2V)	46	62	73	79	80	78	73	65	125-6/9-10	61	76	87	93	94	88	84	77
90-4-5.5	60	76	87	93	94	92	87	79	125-12/9-10 (2V)	46	61	72	78	79	73	69	62
90-8-5.5 (2V)	45	61	72	78	79	77	72	64	125-6/9-15	59	74	85	91	92	86	82	75
90-4-7.5	59	75	86	92	93	91	86	78	125-12/9-15 (2V)	43	58	69	75	76	70	66	59
90-8-7.5 (2V)	44	60	71	77	78	76	71	63	125-6/9-20	59	74	85	91	92	86	82	75
90-4-10	58	74	85	91	92	90	85	77	125-6/9-24	60	75	86	92	93	87	83	76
90-8-10 (2V)	43	59	70	76	77	75	70	62	125-12/9-24 (2V)	45	60	71	77	78	72	68	61
90-6-2	52	67	78	82	82	78	71	63	125-6/9-25	61	76	87	93	94	88	84	77
90-12-2 (2V)	36	51	62	66	66	62	55	47	125-6/9-30	64	79	90	96	97	91	87	80
90-6-3	52	67	78	82	82	78	71	63	125-6/12-10	63	78	89	95	96	90	86	79
90-12-3 (2V)	37	52	63	67	67	63	56	48	125-6/12-15	61	76	87	93	94	88	84	77
90-6-4	60	70	80	85	85	82	76	68	125-6/12-20	60	75	86	92	93	87	83	76
90-12-4 (2V)	45	55	65	70	70	67	61	53	125-6/12-25	61	76	87	93	94	88	84	77
90-8-1	42	63	70	75	78	74	67	56	125-6/12-30	62	77	88	94	95	89	85	78
90-8-2	51	66	73	78	81	77	70	59	125-6/12-40	63	78	89	95	96	90	86	79
90-8-3	53	67	74	79	82	78	71	60	140-6/6-7.5	63	79	91	97	98	96	94	96
100-4-7.5	67	83	90	97	98	96	92	84	140-6/6-15	58	74	86	92	93	91	89	91
100-8-7.5 (2V)	52	68	75	82	83	81	77	69	140-6/6-20	57	73	85	91	92	90	88	90
100-4-10	65	81	88	95	96	94	90	82	140-6/6-25	56	72	84	92	94	89	87	89
100-8-10 (2V)	50	66	73	80	81	79	75	67	140-6/6-30	57	73	85	91	92	90	88	90
100-4-15	71	83	87	93	94	94	91	83	140-6/9-15	64	77	89	97	99	95	91	83
100-8-15 (2V)	56	68	72	78	79	79	76	68	140-6/9-20	63	76	88	96	98	94	90	82
100-4-20	72	84	88	94	95	95	92	84	140-6/9-25	62	75	87	95	97	93	89	81
100-8-20 (2V)	57	69	73	79	80	80	77	69	140-6/9-30	61	74	86	94	96	92	88	80
100-4/9-15	65	81	88	95	96	94	90	82	140-6/9-40	61	74	86	94	96	92	88	80
100-4/9-20	72	84	88	94	95	95	92	84	140-6/9-50	52	65	76	85	91	94	98	92
100-4/9-25	72	84	88	94	95	95	92	84	140-6/9-60	54	67	78	87	93	96	100	94
100-4/9-30	74	86	90	96	97	97	94	86	140-6/12-30	63	76	88	96	98	94	90	82
100-6-3	57	72	82	85	86	83	75	67	140-6/12-40	62	75	87	95	97	93	89	81
100-12-3 (2V)	42	57	67	70	71	68	60	52	140-6/12-50	53	66	77	86	92	95	99	93
100-6-4	56	71	81	84	85	82	74	66	140-6/12-60	54	67	78	87	93	96	100	94
100-12-4 (2V)	41	56	66	69	70	67	59	51	140-6/12-75	55	68	79	88	94	97	101	95
100-6-5.5	57	72	82	85	86	83	75	67	160-6/6-20	67	83	92	99	100	98	97	97
100-6/9-5.5	57	72	82	85	86	83	75	67	160-6/6-25	66	82	91	98	99	97	96	96
100-6/9-7.5	58	73	83	86	87	84	76	68	160-6/6-30	66	82	91	98	99	96	96	96
100-6/9-10	61	76	86	89	90	87	79	71	160-6/6-40	64	80	89	96	97	95	94	94
125-4/6-20	69	85	96	103	104	102	95	87	160-6/6-50	64	80	89	96	97	94	94	94
125-8/6-20 (2V)	54	70	81	88	89	87	80	72	160-6/6-60	64	80	89	96	97	95	94	94
125-4/6-25	68	84	95	102	103	101	94	86	160-6/6-75	56	69	78	86	92	97	100	100
125-4/6-27	67	83	94	101	102	100	93	85	160-6/9-25	75	88	97	105	107	105	100	91
125-8/6-27 (2V)	52	68	79	86	87	85	78	70	160-6/9-30	73	86	95	103	105	103	98	89
125-4/6-30	67	83	94	101	102	100	93	85	160-6/9-40	71	84	93	101	103	101	96	87
125-4/6-37	67	83	94	101	102	100	93	85	160-6/9-50	70	83	92	100	102	100	95	86
125-8/6-37 (2V)	52	68	79	86	87	85	78	70	160-6/9-60	70	83	92	100	102	100	95	86
125-4/6-40	67	83	94	101	102	100	93	85	160-6/9-75	59	72	80	87	88	100	103	96
125-4/6-50	67	83	94	101	102	100	93	85	160-6/12-60	71	84	93	101	103	101	96	87
125-4/6-60	67	83	94	101	102	100	93	85	160-6/12-75	60	73	81	88	89	101	104	97
125-4/6-75	70	86	97	104	105	103	96	88									

Dimensiones mm

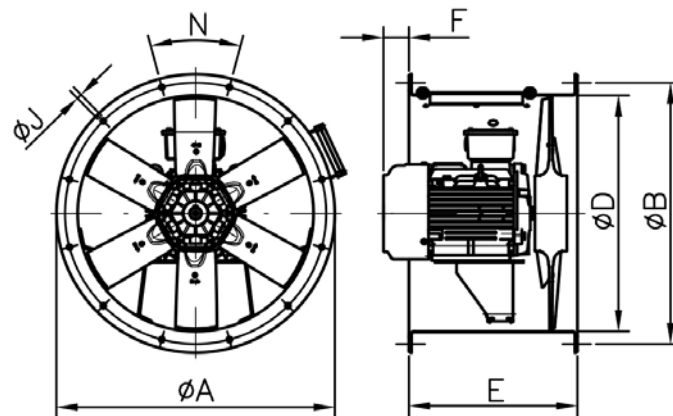

Tamaño motor	ØA	ØB	ØD	E	F*	ØJ	N	
THT/CL-40	80	490	450	410	400	-	12	8x45°
THT/CL-40	90S	490	450	410	400	-	12	8x45°
THT/CL-40	90L	490	450	410	400	29	12	8x45°
THT/CL-45	80	540	500	460	400	-	12	8x45°
THT/CL-45	90S	540	500	460	400	-	12	8x45°
THT/CL-45	90L	540	500	460	400	29	12	8x45°
THT/CL-45	100	540	500	460	400	35	12	8x45°
THT/CL-50	80	600	560	514	400	-	12	12x30°
THT/CL-50	90S	600	560	514	400	-	12	12x30°
THT/CL-50	90L	600	560	514	400	29	12	12x30°
THT/CL-50	100	600	560	514	400	35	12	12x30°
THT/CL-50	112	600	560	514	400	56,5	12	12x30°
THT/CL-56	80	660	620	560	400	-	12	12x30°
THT/CL-56	90S	660	620	560	400	-	12	12x30°
THT/CL-56	90L	660	620	560	400	29	12	12x30°
THT/CL-56	100	660	620	560	500	-	12	12x30°
THT/CL-56	112	660	620	560	500	60,5	12	12x30°
THT/CL-56	132S	660	620	560	500	15	12	12x30°
THT/CL-56	132M	660	620	560	500	53	12	12x30°
THT/CL-63	80	730	690	640	400	-	12	12x30°
THT/CL-63	90S	730	690	640	400	-	12	12x30°
THT/CL-63	90L	730	690	640	400	29	12	12x30°
THT/CL-63	100	730	690	640	500	-	12	12x30°
THT/CL-63	112	730	690	640	500	-	12	12x30°
THT/CL-63	132S	730	690	640	500	43	12	12x30°
THT/CL-63	132M	730	690	640	500	81	12	12x30°
THT/CL-63	160M	730	690	640	650	-	12	12x30°
THT/CL-63	160L	730	690	640	650	29	12	12x30°
THT/CL-71	80	810	770	710	430	-	12	16x22°30'
THT/CL-71	90S	810	770	710	430	-	12	16x22°30'
THT/CL-71	90L	810	770	710	430	19	12	16x22°30'
THT/CL-71	100	810	770	710	430	24	12	16x22°30'
THT/CL-71	112	810	770	710	500	-	12	16x22°30'
THT/CL-80	90L	900	860	800	430	27	12	16x22°30'
THT/CL-80	100	900	860	800	500	-	12	16x22°30'
THT/CL-80	112	900	860	800	500	-	12	16x22°30'
THT/CL-80	132S	900	860	800	600	-	12	16x22°30'

Tamaño motor	ØA	ØB	ØD	E	F*	ØJ	N	
THT/CL-90	100	1015	970	900	600	-	15	16x22°30'
THT/CL-90	112	1015	970	900	600	-	15	16x22°30'
THT/CL-90	132S	1015	970	900	600	-	15	16x22°30'
THT/CL-90	132M	1015	970	900	600	-	15	16x22°30'
THT/CL-100	112	1115	1070	1000	600	-	15	16x22°30'
THT/CL-100	132S	1115	1070	1000	600	-	15	16x22°30'
THT/CL-100	132M	1115	1070	1000	600	-	15	16x22°30'
THT/CL-100	160M	1115	1070	1000	700	-	15	16x22°30'
THT/CL-100	160L	1115	1070	1000	700	2	15	16x22°30'
THT/CL-100	180M	1115	1070	1000	700	11	15	16x22°30'
THT/CL-100	180L	1115	1070	1000	700	49	15	16x22°30'
THT/CL-125	132M	1365	1320	1250	700	-	15	20x18°
THT/CL-125	160M	1365	1320	1250	700	-	15	20x18°
THT/CL-125	160L	1365	1320	1250	700	-	15	20x18°
THT/CL-125	180M	1365	1320	1250	900	-	15	20x18°
THT/CL-125	180L	1365	1320	1250	900	-	15	20x18°
THT/CL-125	200	1365	1320	1250	900	-	15	20x18°
THT/CL-125	225	1365	1320	1250	1000	-	15	20x18°
THT/CL-125	250	1365	1320	1250	1000	25,5	15	20x18°
THT/CL-125	280	1365	1320	1250	1200	-	15	20x18°
THT/CL-140	132S	1515	1470	1400	650	-	15	20x18°
THT/CL-140	132M	1515	1470	1400	650	-	15	20x18°
THT/CL-140	160L	1515	1470	1400	700	5	15	20x18°
THT/CL-140	180L	1515	1470	1400	900	-	15	20x18°
THT/CL-140	200	1515	1470	1400	900	-	15	20x18°
THT/CL-140	225	1515	1470	1400	1000	-	15	20x18°
THT/CL-140	250	1515	1470	1400	1000	5,5	15	20x18°
THT/CL-140	280	1515	1470	1400	1200	5,5	15	20x18°
THT/CL-160	132S	1735	1680	1600	650	-	19	24x15°
THT/CL-160	132M	1735	1680	1600	650	-	19	24x15°
THT/CL-160	160L	1735	1680	1600	700	5	19	24x15°
THT/CL-160	180L	1735	1680	1600	900	-	19	24x15°
THT/CL-160	200	1735	1680	1600	900	-	19	24x15°
THT/CL-160	225	1735	1680	1600	1000	-	19	24x15°
THT/CL-160	250	1735	1680	1600	1000	30,5	19	24x15°
THT/CL-160	280	1735	1680	1600	1200	-	19	24x15°

* La cota F únicamente aplica a los modelos F400.

Tamaños constructivos motores según potencia (1 velocidad)

	CV											
	0,75	1	1,5	2	3	4	5,5	7,5	10	12	15	20
2T (3000 r/min)	80	80	80	90S	90L	100LB	112M	132S	132S	132MA	160M	160M
4T (1500 r/min)	80	90S	90S	90L	100LA	100LB	112M	132S	132M	-	160ML	160L
6T (1000 r/min)	90S	90S	90L	100L	112M	132S	132MA	132MB	160M	-	160L	180ML
8T (750 r/min)	90L	100LA	100L	112M	132S	132M	160MA	160M	160L	-	180L	200MLA

	CV							
	22	25	30	40	50	60	75	100
2T (3000 r/min)	160L	180M	180L	200L	225S/M	225S/M	250S/M	280S/M
4T (1500 r/min)	-	180M	180L	200L	225S/M	225S/M	250S/M	280S/M
6T (1000 r/min)	-	200MLA	200MLB	225SMB	250S/M	280S/M	280S/M	-
8T (750 r/min)	-	225SMA	225SMB	250SMA	280S/M	280S/M	-	-

Tamaños constructivos motores según potencia (2 velocidades)

	CV											
	0,75	1	1,5	2	3	4	5,5	6	7,5	8	9	10
2/4 (3000/1500 r/min)	-	-	90S	90S	90L	100L	-	112M	-	-	132M	-
4/8 (1500/750 r/min)	-	-	90S	100L	100LA	100LC	132S	-	132S	132S	132ML	132M
6/12 (1000/500 r/min)	90L	100L	100LB	112M	112M	132MC	160M	160M	160LB	160LB	-	160LB

	CV									
	12	15	18	20	22	24	27	37	38	40
2/4 (3000/1500 r/min)	160MA	-	160M	-	160L	-	-	-	-	-
4/8 (1500/750 r/min)	-	160M	-	160L	180M	180M	180L	200MLA	200L	225S/M
6/12 (1000/500 r/min)	-	200MLC	160L	200M	-	250SMB	225S/M	-	225S/M	-

Curvas características

Ver curvas características serie: THT

Accesorios



INT



IAT



CABLE BOX



C2V



VSD3/A-RFT
- VSD1/A-RFM



CENTRAL CO



AET



P-400

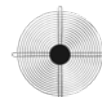

RT



R/THT



BTUB



BAC



PS



ACE ACE/400



S



SC



BOXPARK

Configuración con BOXPARK



Cuadros de control para sistemas de ventilación de aparcamientos con triple propósito: ventilación diaria, control de la concentración de CO y extracción de humo en caso de incendio

Cuadros de control en envoltorio metálica con todos los elementos necesarios para la gestión y control de los ventiladores de sistemas de ventilación de aparcamientos, ya estén basados en redes de conductos o en ventiladores de impulsos, para el control de los niveles de concentración de CO y la extracción de humo en caso de incendio. Cuadros a medida para todas las potencias y número de ventiladores según necesidades del proyecto.

Más información ver serie BOXPARK.

Ejemplos de instalación con BOXPARK

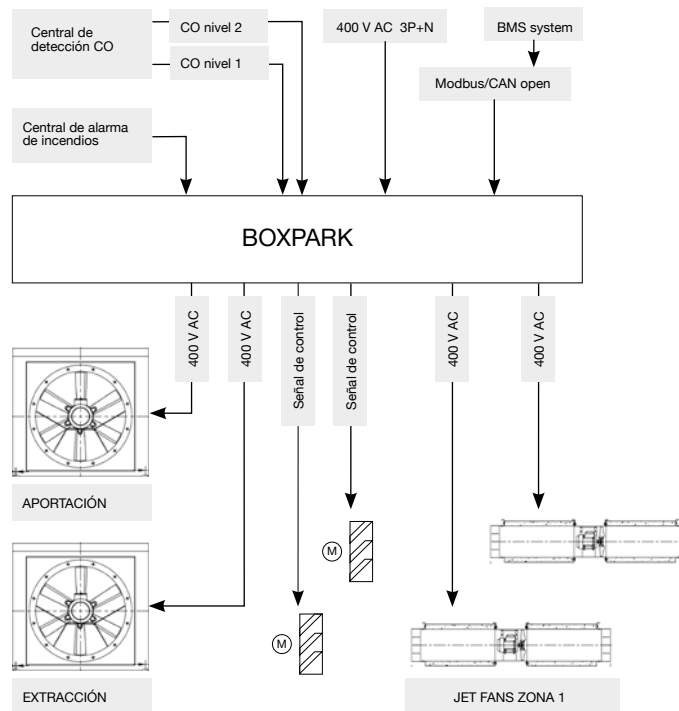

THT/WALL



Extractores dinámicos murales con compuerta de apertura motorizada, para la evacuación de humo en caso de incendio, 400 °C/2h y 300 °C/2h



Extractores dinámicos murales de apertura motorizada, con posibilidad de ser conectados a conducto de extracción. Especialmente diseñados para la rápida y eficaz evacuación de humo y gases nocivos en caso de incendio. Apto para instalación en naves industriales, edificios comerciales o cualquier otro tipo de edificación. Homologación de todo el conjunto según norma EN-12101-3, con certificación F400 y F300. Puede utilizarse para la ventilación ambiental.

Ventilador:

- Brida de fijación a pared y pie soporte aro helicoidal para la correcta y fácil instalación.
- Con certificaciones n°: 0370-CPR-2823 (F400) y 0370-CPR-0973 (F300).
- Envoltorio tubular en chapa de acero con tratamiento anticorrosivo en resina de poliéster.
- Hélice de ángulo variable en fundición de aluminio.
- Cable de potencia apantallado con protección EMC.
- Dirección aire motor-hélice.

Compuerta de aluminio extruido:

- Estructura de gran robustez para resistir severas condiciones climáticas.
- Diseñado para asegurar la estanqueidad a la entrada de agua.
- Perfil de aluminio con rotura de puente térmico.

- Plafón central y estructura dotados de aislante térmico de altas prestaciones.
- Resistividad térmica del conjunto menor que 0.89 W/m²·K.
- Interruptores final de carrera en ambas posiciones (abierto y cerrado).
- Sistema de apertura manual.

Motor:

- Motores clase H para uso continuo S1 y uso emergencia S2. Con rodamientos a bolas, protección IP55 y 1 o 2 velocidades según modelo.
- Motores con eficiencia IE3.
- Trifásico 230/400 V 50 Hz (hasta 3 kW) y 400/690 V 50 Hz (potencias superiores a 3 kW).
- Temperatura máxima del aire a transportar: Servicio S1 -25 °C +40 °C en continuo, apto también para climas cálidos con temperaturas hasta 50 °C. Servicio S2 300 °C/2h, 400 °C/2h.

Actuador:

- Fiabilidad mayor a 11.000 dobles ciclos.
- Tensión de alimentación 230 V AC 50/60 Hz.
- Temperatura de trabajo: -25 °C +60 °C.

Acabado compuerta:

- Anticorrosivo en aluminio extruido.
- Color estándar RAL 7016. Bajo demanda cualquier color de la carta RAL.

Código de pedido

De tamaño 40 a tamaño 100

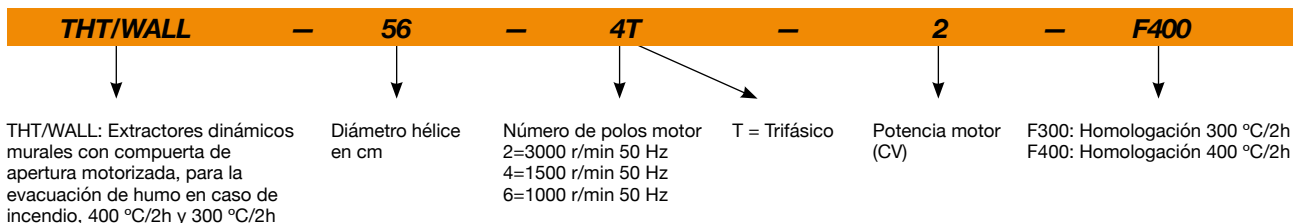

Tamaño 125

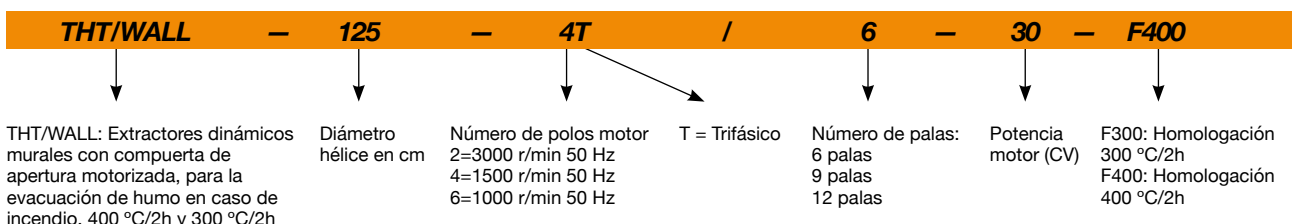

Características técnicas

Modelo	Velocidad (r/min)	Intensidad máxima admisible (A)			Potencia instalada (kW)	Ángulo inclinación palas (°)	Caudal máximo (m³/h)	Nivel presión sonora ¹ dB (A)		Peso aprox. (Kg)
		230V	400V	690V				Aspiración	Descarga	
THT/WALL-40-2T-1 IE3	2850	2,76	1,59		0,75	16	6100	62	62	62
THT/WALL-40-2T-1.5 IE3	2880	3,93	2,26		1,10	20	7040	61	61	63
THT/WALL-45-2T-2 IE3	2880	4,91	2,84		1,50	16	9400	61	61	67
THT/WALL-45-2T-3 IE3	2840	7,14	4,13		2,20	22	11325	61	61	68
THT/WALL-50-2T-4 IE3	2880	9,61	5,52		3,00	16	13860	66	66	84
THT/WALL-50-2T-5.5 IE3	2870		7,20	4,17	4,00	20	15900	66	66	100
THT/WALL-56-2T-5.5 IE3	2870		7,20	4,17	4,00	16	18820	68	68	105
THT/WALL-56-2T-7.5 IE3	2910		10,10	5,80	5,50	22	22510	68	68	107
THT/WALL-56-4T-2 IE3	1440	5,89	3,38		1,50	36	15020	54	54	84
THT/WALL-63-4T-3 IE3	1425	7,86	4,52		2,20	32	22170	58	58	131
THT/WALL-63-4T-4 IE3	1430	11,01	6,33		3,00	38	24240	59	59	132
THT/WALL-63-6T-1 IE3	940	3,36	1,93		0,75	38	15890	48	48	121
THT/WALL-71-4T-3 IE3	1425	7,86	4,52		2,20	22	25100	60	60	124
THT/WALL-71-4T-4 IE3	1430	11,01	6,33		3,00	28	27480	60	60	133
THT/WALL-71-4T-5.5 IE3	1440		7,95	4,61	4,00	38	32250	61	61	143
THT/WALL-71-6T-1.5 IE3	945	4,73	2,72		1,10	34	19930	51	51	123
THT/WALL-80-4T-3 IE3	1425	7,86	4,52		2,20	12	25460	65	65	138
THT/WALL-80-4T-4 IE3	1430	11,01	6,33		3,00	16	30270	64	64	147
THT/WALL-80-4T-5.5 IE3	1440		7,95	4,61	4,00	18	32770	63	63	153
THT/WALL-80-4T-7.5 IE3	1460		10,40	6,04	5,50	26	39640	63	63	154
THT/WALL-80-6T-1.5 IE3	945	4,73	2,72		1,10	18	21470	53	53	137
THT/WALL-80-6T-2 IE3	945	6,25	3,62		1,50	26	25970	54	54	146
THT/WALL-90-4T-7.5 IE3	1460		10,40	6,04	5,50	18	46140	67	67	222
THT/WALL-90-4T-10 IE3	1460		14,20	8,17	7,50	22	50140	66	66	233
THT/WALL-90-4T-15 IE3	1460		20,70	11,99	11,00	30	59390	68	68	242
THT/WALL-90-6T-3 IE3	950	9,78	5,62		2,20	24	34000	56	56	195
THT/WALL-90-6T-4 IE3	970	12,80	6,36		3,00	30	38910	59	59	221
THT/WALL-100-4T-10 IE3	1460		14,20	8,17	7,50	16	57420	69	69	239
THT/WALL-100-4T-15 IE3	1460		20,70	11,99	11,00	22	66300	69	69	292
THT/WALL-100-4T-20 IE3	1460		27,80	16,03	15,00	28	76160	70	70	307
THT/WALL-100-6T-5.5 IE3	970	8,37	4,82		4,00	26	47780	60	60	239
THT/WALL-100-6T-7.5 IE3	970	12,30	7,07		5,50	32	53520	62	62	276
THT/WALL-125-4T/6-20 IE3	1460		27,80	16,03	15,00	10	78600	77	77	462
THT/WALL-125-4T/6-25 IE3	1465		35,40	20,39	18,50	14	92550	76	76	530
THT/WALL-125-4T/6-30 IE3	1470		42,20	24,44	22,00	16	98830	75	75	544
THT/WALL-125-4T/6-40 IE3	1475		53,30	31,02	30,00	22	117450	75	75	625
THT/WALL-125-4T/6-50 IE3	1480		66,40	38,26	37,00	26	131050	75	75	673
THT/WALL-125-4T/9-25 IE3	1465		35,40	20,39	18,50	10	79650	77	77	539
THT/WALL-125-4T/9-30 IE3	1470		42,20	24,44	22,00	12	88290	76	76	553
THT/WALL-125-4T/9-40 IE3	1475		53,30	31,02	30,00	16	104040	75	75	634
THT/WALL-125-4T/9-50 IE3	1480		66,40	38,26	37,00	20	118400	75	75	682
THT/WALL-125-4T/12-30 IE3	1475		42,20	24,44	22,00	10	62900	78	78	569
THT/WALL-125-4T/12-40 IE3	1470		53,30	31,02	30,00	14	79180	77	77	650
THT/WALL-125-4T/12-50 IE3	1480		66,40	38,26	37,00	18	95715	76	76	693
THT/WALL-125-6T/6-5.5 IE3	970		8,37	4,82	4,00	10	51500	67	67	395
THT/WALL-125-6T/6-7.5 IE3	970		12,30	7,07	5,50	14	60640	65	65	402
THT/WALL-125-6T/6-10 IE3	960		15,20	8,83	7,50	20	72650	64	64	427
THT/WALL-125-6T/6-15 IE3	955		22,50	13,07	11,00	26	85850	64	64	457
THT/WALL-125-6T/6-20 IE3	950		29,00	16,78	15,00	30	92850	66	66	530
THT/WALL-125-6T/9-10 IE3	960		15,20	8,83	7,50	14	63490	67	67	436
THT/WALL-125-6T/9-15 IE3	955		22,50	13,07	11,00	20	77550	65	65	466
THT/WALL-125-6T/9-20 IE3	950		29,00	16,78	15,00	26	92950	65	65	539
THT/WALL-125-6T/9-25 IE3	975		36,10	20,77	18,50	32	96500	67	67	569
THT/WALL-125-6T/12-25 IE3	975		36,10	20,77	18,50	28	91680	67	67	579
THT/WALL-125-6T/12-30 IE3	975		42,30	24,35	22,00	32	102050	68	68	621
THT/WALL-125-6T/12-40 IE3	980		55,80	32,13	30,00	38	115950	72	72	739

¹ Los valores de los niveles sonoros, son presiones en dB(A) medidos a 10 metros, en campo libre.

Características técnicas del exutorio dinámico según normas EN-12101-3

Modelo	Homologación (°C)	Clase aislamiento motor	Durabilidad	Temperatura ambiente mínima (°C)	Carga de viento (Pa)
THT/WALL	F300 y F400	Clase H	RE 11000	-25	WL 200



Erp. (Energy Related Products)

Información de la Directiva 2009/125/EC descargable desde la web de SODECA o programa de selección QuickFan.

Características acústicas

Espectro de potencia sonora Lw(A) en dB(A) por banda de frecuencia en Hz

Valores tomados a la aspiración con caudal máximo

	63	125	250	500	1000	2000	4000	8000
40-2-1	48	64	76	84	89	87	83	76
40-2-1.5	47	63	75	83	88	86	82	75
45-2-2	47	60	74	86	87	86	82	74
45-2-3	47	64	74	81	88	86	83	75
50-2-4	58	74	84	91	92	89	88	89
50-2-5.5	58	74	84	91	92	89	88	89
56-2-5.5	53	66	84	92	94	93	88	81
56-2-7.5	53	66	84	92	94	93	88	81
56-4-2	52	64	73	79	79	79	73	65
63-4-3	56	68	77	83	83	83	77	69
63-4-4	57	69	78	84	84	84	78	70
63-6-1	49	59	69	73	74	72	65	57
71-4-3	56	72	79	85	85	85	81	73
71-4-4	63	75	79	85	85	86	83	75
71-4-5.5	64	76	80	86	86	87	84	76
71-6-1.5	47	65	74	77	77	72	65	56
80-4-3	55	71	84	91	91	88	82	74
80-4-4	54	70	83	90	90	87	81	73
80-4-5.5	53	69	82	89	89	86	80	72
80-4-7.5	53	69	82	89	89	86	80	72
80-6-1.5	53	68	75	78	79	76	70	62
80-6-2	59	69	75	79	80	78	73	65
90-4-7.5	59	75	86	92	93	91	86	78
90-4-10	58	74	85	91	92	90	85	77
90-4-15	60	76	87	93	94	92	87	79
90-6-3	52	67	78	82	82	78	71	63
90-6-4	60	70	80	85	85	82	76	68
100-4-10	64	80	87	94	95	93	89	81
100-4-15	71	83	87	93	94	94	91	83
100-4-20	72	84	88	94	95	95	92	84
100-6-5.5	57	72	82	85	86	83	75	67
100-6-7.5	59	74	84	87	88	85	77	69
125-4/6-20	69	85	96	103	104	102	95	87
125-4/6-25	68	84	95	102	103	101	94	86
125-4/6-30	67	83	94	101	102	100	93	85
125-4/6-40	67	83	94	101	102	100	93	85
125-4/6-50	67	83	94	101	102	100	93	85
125-4/9-25	67	81	94	102	104	101	96	88
125-4/9-30	66	80	93	101	103	100	95	87
125-4/9-40	65	79	92	100	102	99	94	86
125-4/9-50	65	79	92	100	102	99	94	86
125-6/6-5.5	64	79	89	92	93	90	85	77
125-6/6-7.5	62	77	87	90	91	88	83	75
125-6/6-10	61	76	86	89	90	87	82	74
125-6/6-15	61	76	86	89	90	87	82	74
125-6/6-20	63	78	88	91	92	89	84	76
125-6/9-10	61	76	87	93	94	88	84	77
125-6/9-15	59	74	85	91	92	86	82	75
125-6/9-20	59	74	85	91	92	86	82	75
125-6/9-25	61	76	87	93	94	88	84	77
125-4/12-30	68	82	95	103	105	102	97	89
125-4/12-40	67	81	94	102	104	101	96	88
125-4/12-50	66	80	93	101	103	100	95	87
125-6/12-25	61	76	87	93	94	88	84	77
125-6/12-30	62	77	88	94	95	89	85	78
125-6/12-40	66	81	92	98	99	93	89	82

Valores tomados a la descarga con caudal máximo

	63	125	250	500	1000	2000	4000	8000
40-2-1	48	64	76	84	89	87	83	76
40-2-1.5	47	63	75	83	88	86	82	75
45-2-2	47	60	74	86	87	86	82	74
45-2-3	47	64	74	81	88	86	83	75
50-2-4	58	74	84	91	92	89	88	89
50-2-5.5	58	74	84	91	92	89	88	89
56-2-5.5	53	66	84	92	94	93	88	81
56-2-7.5	53	66	84	92	94	93	88	81
56-4-2	52	64	73	79	79	79	73	65
63-4-3	56	68	77	83	83	83	77	69
63-4-4	57	69	78	84	84	84	78	70
63-6-1	49	59	69	73	74	72	65	57
71-4-3	56	72	79	85	85	85	81	73
71-4-4	63	75	79	85	85	86	83	75
71-4-5.5	64	76	80	86	86	87	84	76
71-6-1.5	47	65	74	77	77	72	65	56
80-4-3	55	71	84	91	91	88	82	74
80-4-4	54	70	83	90	90	87	81	73
80-4-5.5	53	69	82	89	89	86	80	72
80-4-7.5	53	69	82	89	89	86	80	72
80-6-1.5	53	68	75	78	79	76	70	62
80-6-2	59	69	75	79	80	78	73	65
90-4-7.5	59	75	86	92	93	91	86	78
90-4-10	58	74	85	91	92	90	85	77
90-4-15	60	76	87	93	94	92	87	79
90-6-3	52	67	78	82	82	78	71	63
90-6-4	60	70	80	85	85	82	76	68
100-4-10	64	80	87	94	95	93	89	81
100-4-15	71	83	87	93	94	94	91	83
100-4-20	72	84	88	94	95	95	92	84
100-6-5.5	57	72	82	85	86	83	75	67
100-6-7.5	59	74	84	87	88	85	77	69
125-4/6-20	69	85	96	103	104	102	95	87
125-4/6-25	68	84	95	102	103	101	94	86
125-4/6-30	67	83	94	101	102	100	93	85
125-4/6-40	67	83	94	101	102	100	93	85
125-4/6-50	67	83	94	101	102	100	93	85
125-4/9-25	67	81	94	102	104	101	96	88
125-4/9-30	66	80	93	101	103	100	95	87
125-4/9-40	65	79	92	100	102	99	94	86
125-4/9-50	65	79	92	100	102	99	94	86
125-6/6-5.5	64	79	89	92	93	90	85	77
125-6/6-7.5	62	77	87	90	91	88	83	75
125-6/6-10	61	76	86	89	90	87	82	74
125-6/6-15	61	76	86	89	90	87	82	74
125-6/6-20	63	78	88	91	92	89	84	76
125-6/9-10	61	76	87	93	94	88	84	77
125-6/9-15	59	74	85	91	92	86	82	75
125-6/9-20	59	74	85	91	92	86	82	75
125-6/9-25	61	76	87	93	94	88	84	77
125-4/12-30	68	82	95	103	105	102	97	89
125-4/12-40	67	81	94	102	104	101	96	88
125-4/12-50	66	80	93	101	103	100	95	87
125-6/12-25	61	76	87	93	94	88	84	77
125-6/12-30	62	77	88	94	95	89	85	78
125-6/12-40	66	81	92	98	99	93	89	82

Dimensiones mm

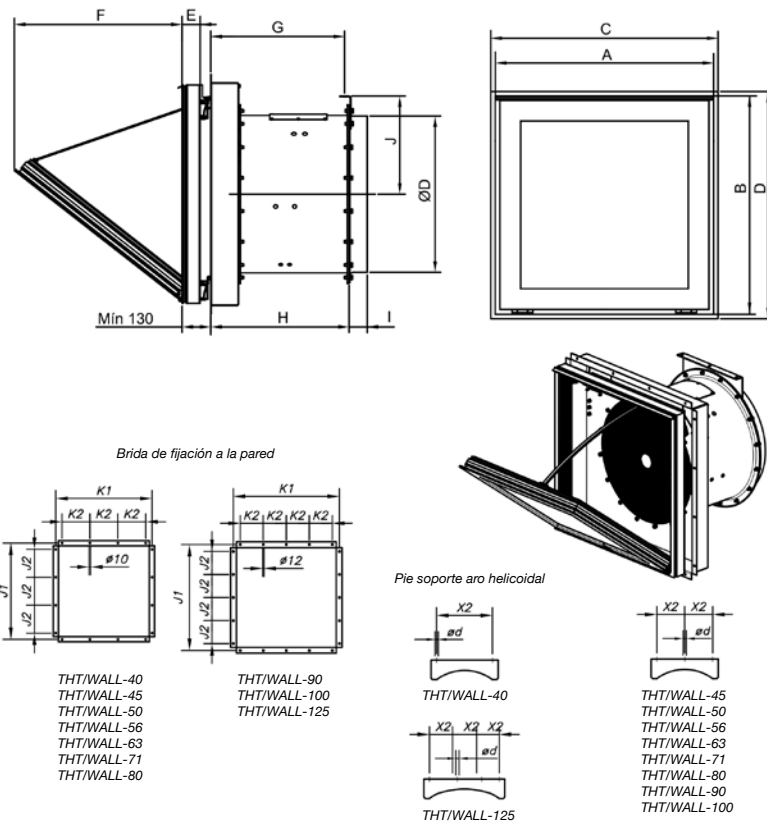

	A	B	C	D	ØD*	I	J	H	G	E	F	J1	J2	K1	K2	X2	ød
THT/WALL-40	640	590	650	600	400	80	255	530	510	82	430	700	200	700	200	200	10
THT/WALL-45	640	590	650	600	450	80	280	530	510	82	430	700	200	700	200	200	12
THT/WALL-50	690	690	700	700	500	80	305	530	510	82	560	790	220	790	220	200	12
THT/WALL-56	690	690	700	700	560	80	340	530	510	82	560	790	220	790	220	215	13
THT/WALL-56-2T-7.5	690	690	700	700	560	80	340	630	610	82	560	790	220	790	220	215	13
THT/WALL-63	990	990	1000	1000	630	80	385	630	605	82	760	1050	300	1050	300	215	13
THT/WALL-63-6T-1	990	990	1000	1000	630	80	385	530	505	82	760	1050	300	1050	300	215	13
THT/WALL-71	990	990	1000	1000	710	80	445	630	605	82	760	1050	300	1050	300	225	13
THT/WALL-80	990	990	1000	1000	800	100	490	630	605	82	760	1050	300	1050	300	280	13
THT/WALL-90	1190	1190	1200	1200	900	100	550	730	705	82	790	1250	250	1250	250	280	18
THT/WALL-90-4T-15	1190	1190	1200	1200	900	100	550	830	805	82	790	1250	250	1250	250	280	18
THT/WALL-100	1190	1190	1200	1200	1000	100	600	730	705	82	790	1250	250	1250	250	280	18
THT/WALL-100-4T-15	1190	1190	1200	1200	1000	100	600	830	805	82	790	1250	250	1250	250	280	18
THT/WALL-100-4T-20	1190	1190	1200	1200	1000	100	600	830	805	82	790	1250	250	1250	250	280	18
THT/WALL-125	1490	1490	1500	1500	1250	100	725	1050	1025	82	1240	1600	300	1600	300	300	18
THT/WALL-125-4T/6-20	1490	1490	1500	1500	1250	100	725	850	825	82	1240	1600	300	1600	300	300	18
THT/WALL-125-6T/6-5.5	1490	1490	1500	1500	1250	100	725	850	825	82	1240	1600	300	1600	300	300	18
THT/WALL-125-6T/6-7.5	1490	1490	1500	1500	1250	100	725	850	825	82	1240	1600	300	1600	300	300	18
THT/WALL-125-6T/6-10	1490	1490	1500	1500	1250	100	725	850	825	82	1240	1600	300	1600	300	300	18
THT/WALL-125-6T/6-15	1490	1490	1500	1500	1250	100	725	850	825	82	1240	1600	300	1600	300	300	18
THT/WALL-125-6T/9-10	1490	1490	1500	1500	1250	100	725	850	825	82	1240	1600	300	1600	300	300	18
THT/WALL-125-6T/9-15	1490	1490	1500	1500	1250	100	725	850	825	82	1240	1600	300	1600	300	300	18
THT/WALL-125-4T/6-50	1490	1490	1500	1500	1250	100	725	1150	1125	82	1240	1600	300	1600	300	300	18
THT/WALL-125-4T/9-50	1490	1490	1500	1500	1250	100	725	1150	1125	82	1240	1600	300	1600	300	300	18
THT/WALL-125-4T/12-50	1490	1490	1500	1500	1250	100	725	1150	1125	82	1240	1600	300	1600	300	300	18

* Diámetro nominal tubería recomendada.
(C x D) Dimensión nominal de apertura de pared.

Curvas características

Q= Caudal en m³/h, m³/s y cfm

Pe= Presión estática en mmH₂O, Pa e in wg

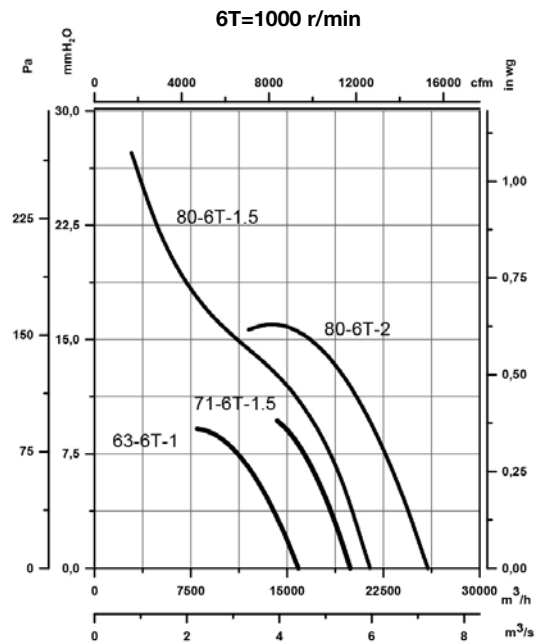
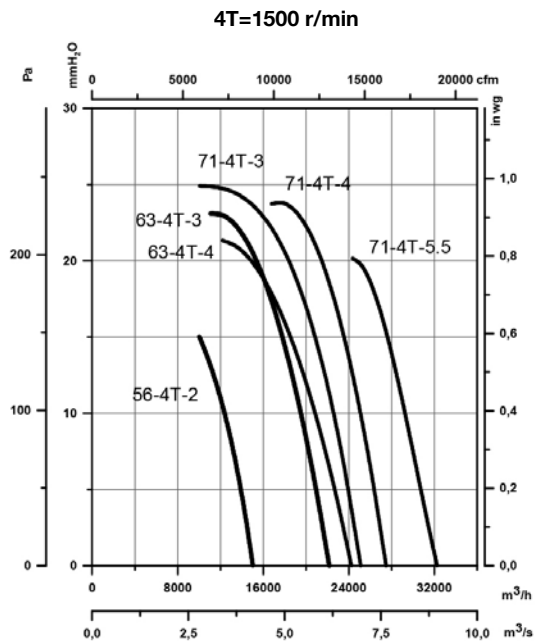
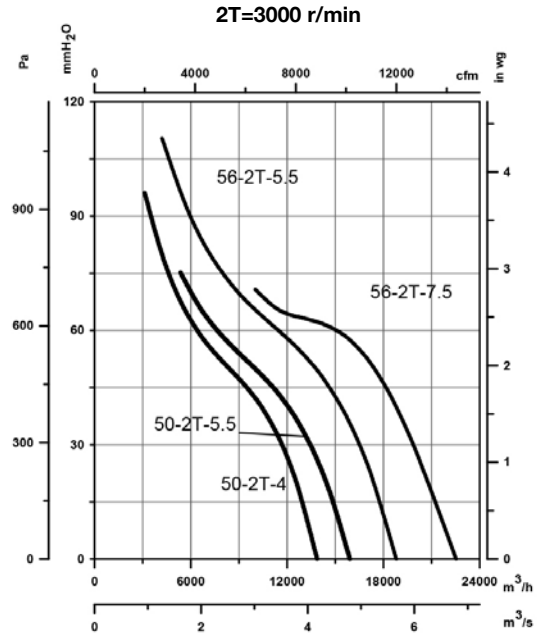
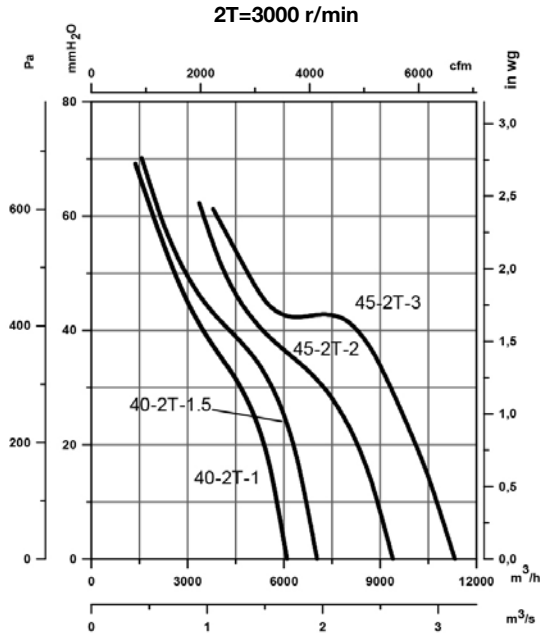

Curvas características

Q= Caudal en m³/h, m³/s y cfm

Pe= Presión estática en mmH₂O, Pa e inwg

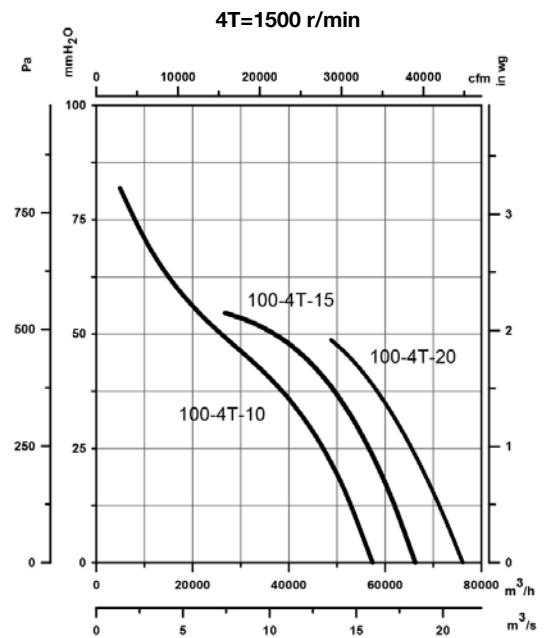
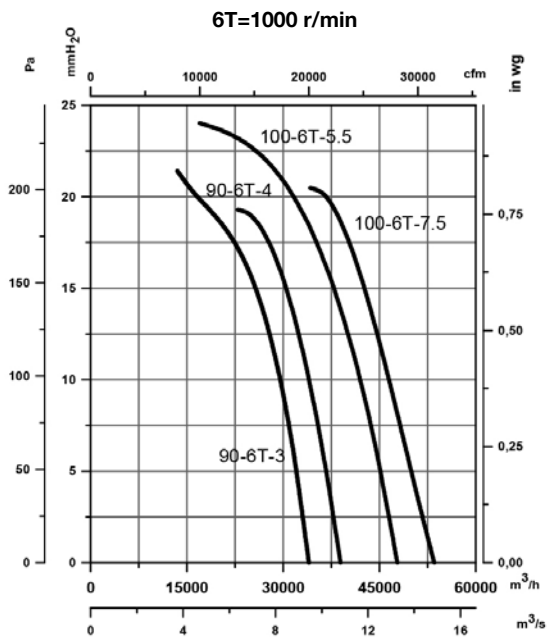
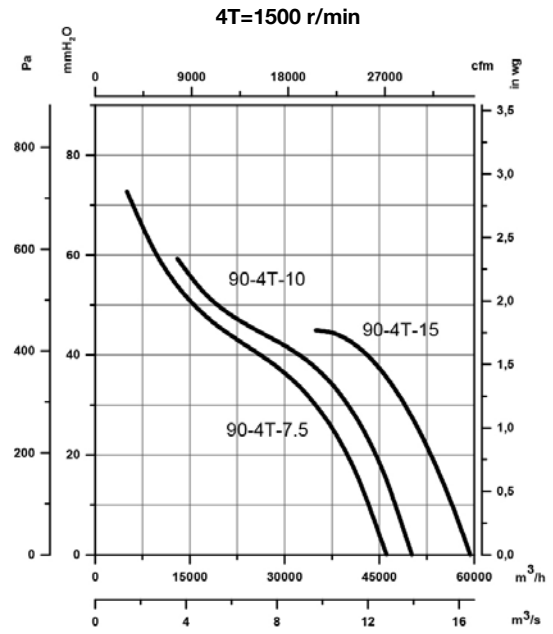
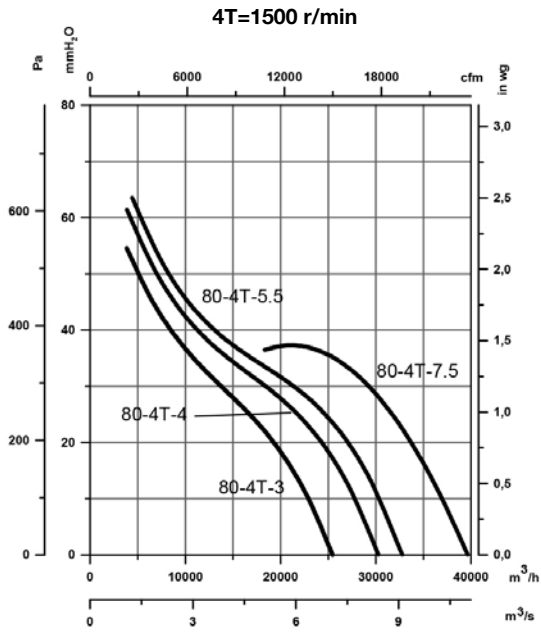

Curvas características

Q= Caudal en m³/h, m³/s y cfm

Pe= Presión estática en mmH₂O, Pa e inwg

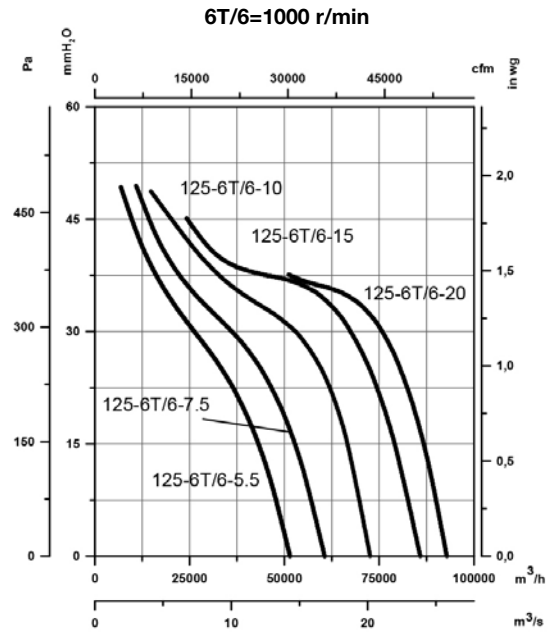
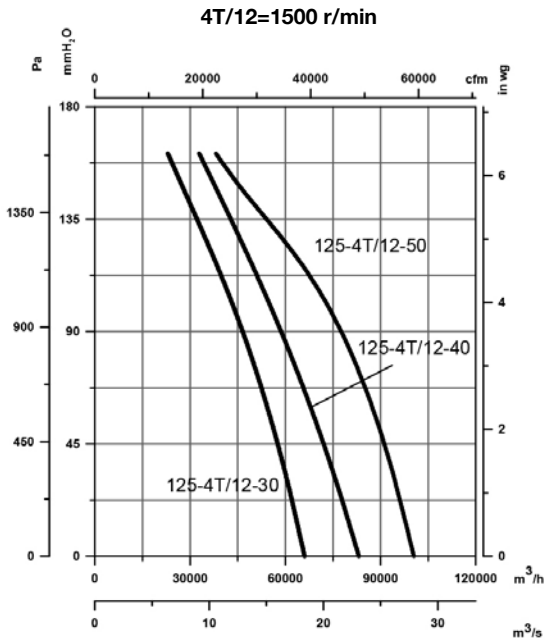
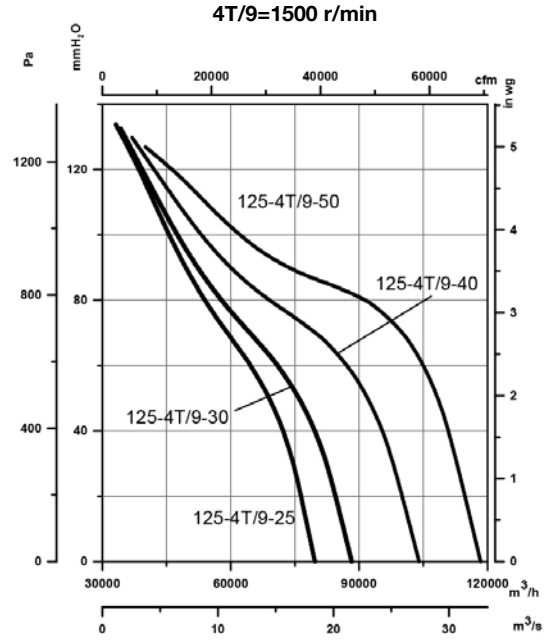
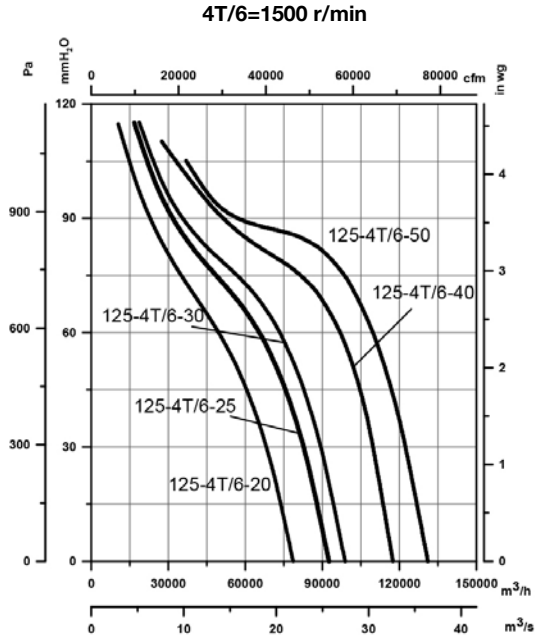

Curvas características

Q= Caudal en m³/h, m³/s y cfm

Pe= Presión estática en mmH₂O, Pa e inwg

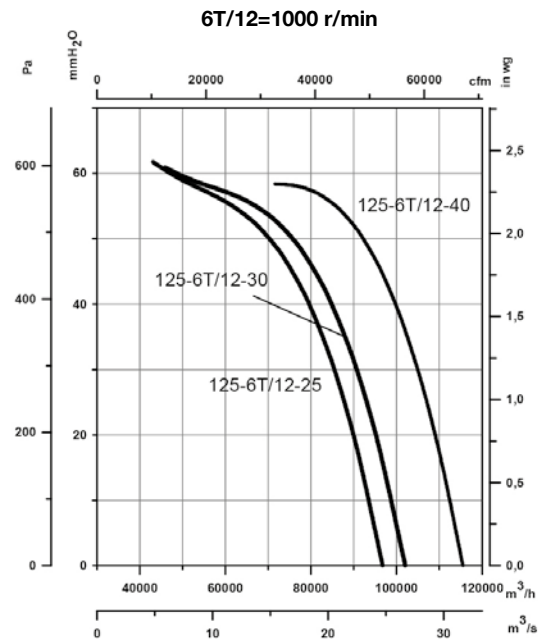
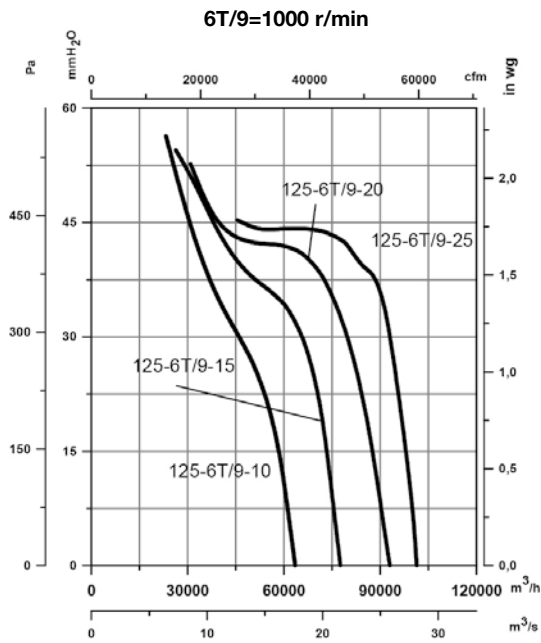

Accesorios



INT



IAT



CABLE BOX



C2V



VSD3/A-RFT
- VSD1/A-RFM



CENTRAL CO



AET



P-400



RT



R/THT



BAC



PS



ACE ACE/400



S

THT/WALL-F



Extractores dinámicos murales con compuerta de apertura motorizada, para la evacuación de humo en caso de incendio, 400 °C/2h y 300 °C/2h



Extractores dinámicos murales de apertura motorizada, con rejilla de protección para su utilización sin conducto de extracción. Especialmente diseñados para la rápida y eficaz evacuación de humo y gases nocivos en caso de incendio. Apto para instalación en naves industriales, edificios comerciales o cualquier otro tipo de edificación. Homologación de todo el conjunto según norma EN-12101-3, con certificación F400 y F300. Puede utilizarse para la ventilación ambiental.

Ventilador:

- Brida de fijación a la pared para la correcta y fácil instalación.
- Marco soporte en chapa de acero galvanizado.
- Con certificaciones nº: 0370-CPR-2823 (F400) y 0370-CPR-0973 (F300).
- Hélice de ángulo variable en fundición de aluminio.
- Cable de potencia apantallado con protección EMC.
- Dirección aire motor-hélice.
- Rejilla de protección contra contactos según norma UNE-EN ISO 12499.

Compuerta de aluminio extruido:

- Estructura de gran robustez para resistir severas condiciones climáticas.
- Diseñado para asegurar la estanqueidad a la entrada de agua.
- Perfil de aluminio con rotura de puente térmico.

- Plafón central y estructura dotados de aislante térmico de altas prestaciones.
- Resistividad térmica del conjunto menor que 0.89 W/m²·K.
- Interruptores final de carrera en ambas posiciones (abierto y cerrado).
- Sistema de apertura manual.

Motor:

- Motores clase H para uso continuo S1 y uso emergencia S2. Con rodamientos a bolas, protección IP55 y 1 o 2 velocidades según modelo.
- Motores con eficiencia IE3.
- Trifásico 230/400 V 50 Hz (hasta 3 kW) y 400/690 V 50 Hz (potencias superiores a 3 kW).
- Temperatura máxima del aire a transportar: Servicio S1 -25 °C +40 °C en continuo, apto también para climas cálidos con temperaturas hasta 50 °C. Servicio S2 300 °C/2h, 400 °C/2h.

Actuador:

- Fiabilidad mayor a 11.000 dobles ciclos.
- Tensión de alimentación 230 V AC 50/60 Hz.
- Temperatura de trabajo: -25 °C +60 °C.

Acabado compuerta:

- Anticorrosivo en aluminio extruido.
- Color estándar RAL 7016. Bajo demanda cualquier color de la carta RAL.

Código de pedido

THT/WALL-F	-	56	-	4T	-	2	-	F400
↓		↓		↓		↓		↓
THT/WALL-F: Extractores dinámicos murales con compuerta de apertura motorizada, para la evacuación de humo en caso de incendio, 400 °C/2h y 300 °C/2h		Diámetro hélice en cm		Número de polos motor 2=3000 r/min 50 Hz 4=1500 r/min 50 Hz 6=1000 r/min 50 Hz		T = Trifásico		Potencia motor (CV)
								F300: Homologación 300 °C/2h F400: Homologación 400 °C/2h

Características técnicas

Modelo	Velocidad (r/min)	Intensidad máxima admisible (A)			Potencia instalada (kW)	Ángulo inclinación palas (°)	Caudal máximo (m³/h)	Nivel presión sonora ¹ dB (A)		Peso aprox. (Kg)
		230V	400V	690V				Aspiración	Descarga	
THT/WALL-F-40-2T-1.5 IE3	2880	3,93	2,26		1,10	20	7040	61	61	55
THT/WALL-F-45-2T-2 IE3	2880	4,91	2,84		1,50	16	9400	61	61	63
THT/WALL-F-45-2T-3 IE3	2840	7,14	4,13		2,20	22	11325	61	61	67
THT/WALL-F-56-4T-2 IE3	1440	5,89	3,38		1,50	36	15020	54	54	69
THT/WALL-F-63-4T-3 IE3	1425	7,86	4,52		2,20	32	22170	58	58	97
THT/WALL-F-63-4T-4 IE3	1430	11,01	6,33		3,00	38	24240	59	59	103
THT/WALL-F-71-4T-3 IE3	1425	7,86	4,52		2,20	22	25100	60	60	100
THT/WALL-F-71-4T-4 IE3	1430	11,01	6,33		3,00	28	27480	60	60	106
THT/WALL-F-71-6T-1.5 IE3	945	4,73	2,72		1,10	34	19930	51	51	98
THT/WALL-F-80-4T-3 IE3	1425	7,86	4,52		2,20	12	25460	65	65	114
THT/WALL-F-80-4T-4 IE3	1430	11,01	6,33		3,00	16	30270	64	64	120
THT/WALL-F-80-4T-5.5 IE3	1440		7,95	4,61	4,00	18	32770	63	63	122
THT/WALL-F-80-4T-7.5 IE3	1460		10,4	6,04	5,50	26	39640	63	63	152
THT/WALL-F-80-6T-1.5 IE3	945	4,73	2,72		1,10	18	21470	53	53	112
THT/WALL-F-80-6T-2 IE3	945	6,25	3,62		1,50	26	25970	54	54	116
THT/WALL-F-90-4T-7.5 IE3	1460		10,4	6,04	5,50	18	46140	67	67	183
THT/WALL-F-90-4T-10 IE3	1460		14,2	8,17	7,50	22	50140	66	66	187
THT/WALL-F-90-6T-3 IE3	950	9,78	5,62		2,20	24	34000	56	56	145
THT/WALL-F-90-6T-4 IE3	970	12,8	6,36		3,00	30	38910	59	59	165
THT/WALL-F-100-4T-10 IE3	1460		14,2	8,17	7,50	16	57420	69	69	194
THT/WALL-F-100-4T-15 IE3	1460		20,7	11,99	11,00	22	66300	69	69	226
THT/WALL-F-100-4T-20 IE3	1460		27,8	16,03	15,00	28	76160	70	70	237
THT/WALL-F-100-6T-5.5 IE3	970		8,37	4,82	4,00	26	47780	60	60	178

¹ Los valores de los niveles sonoros, son presiones en dB(A) medidos a 10 metros, en campo libre.

Características técnicas del exutorio dinámico según normas EN-12101-3

Modelo	Homologación (°C)	Clase aislamiento motor	Durabilidad	Temperatura ambiente mínima (°C)	Carga de viento (Pa)
THT/WALL-F	F300 y F400	Clase H	RE 11000	-25	WL 200



Erp. (Energy Related Products)

Información de la Directiva 2009/125/EC descargable desde la web de SODECA o programa de selección QuickFan.

Características acústicas

Espectro de potencia sonora Lw(A) en dB(A) por banda de frecuencia en Hz

Valores tomados a la aspiración con caudal máximo

	63	125	250	500	1000	2000	4000	8000
40-2-1.5	47	63	75	83	88	86	82	75
45-2-2	47	60	74	86	87	86	82	74
45-2-3	47	64	74	81	88	86	83	75
56-4-2	52	64	73	79	79	79	73	65
63-4-3	56	68	77	83	83	83	77	69
63-4-4	57	69	78	84	84	84	78	70
71-4-3	56	72	79	85	85	85	81	73
71-4-4	63	75	79	85	85	86	83	75
71-6-1.5	47	65	74	77	77	72	65	56
80-4-3	55	71	84	91	91	88	82	74

Valores tomados a la descarga con caudal máximo

	63	125	250	500	1000	2000	4000	8000
40-2-1.5	47	63	75	83	88	86	82	75
45-2-2	47	60	74	86	87	86	82	74
45-2-3	47	64	74	81	88	86	83	75
56-4-2	52	64	73	79	79	79	73	65
63-4-3	56	68	77	83	83	83	77	69
63-4-4	57	69	78	84	84	84	78	70
71-4-3	56	72	79	85	85	85	81	73
71-4-4	63	75	79	85	85	86	83	75
71-6-1.5	47	65	74	77	77	72	65	56
80-4-3	55	71	84	91	91	88	82	74

Características acústicas

Espectro de potencia sonora Lw(A) en dB(A) por banda de frecuencia en Hz

Valores tomados a la aspiración con caudal máximo

	63	125	250	500	1000	2000	4000	8000
80-4-4	54	70	83	90	90	87	81	73
80-4-5.5	53	69	82	89	89	86	80	72
80-4-7.5	53	69	82	89	89	86	80	72
80-6-1.5	53	68	75	78	79	76	70	62
80-6-2	59	69	75	79	80	78	73	65
90-4-7.5	59	75	86	92	93	91	86	78
90-4-10	58	74	85	91	92	90	85	77
90-6-3	52	67	78	82	82	78	71	63
90-6-4	60	70	80	85	85	82	76	68
100-4-10	64	80	87	94	95	93	89	81
100-4-15	71	83	87	93	94	94	91	83
100-4-20	72	84	88	94	95	95	92	84
100-6-5.5	57	72	82	85	86	83	75	67

Valores tomados a la descarga con caudal máximo

	63	125	250	500	1000	2000	4000	8000
80-4-4	54	70	83	90	90	87	81	73
80-4-5.5	53	69	82	89	89	86	80	72
80-4-7.5	53	69	82	89	89	86	80	72
80-6-1.5	53	68	75	78	79	76	70	62
80-6-2	59	69	75	79	80	78	73	65
90-4-7.5	59	75	86	92	93	91	86	78
90-4-10	58	74	85	91	92	90	85	77
90-6-3	52	67	78	82	82	78	71	63
90-6-4	60	70	80	85	85	82	76	68
100-4-10	64	80	87	94	95	93	89	81
100-4-15	71	83	87	93	94	94	91	83
100-4-20	72	84	88	94	95	95	92	84
100-6-5.5	57	72	82	85	86	83	75	67

Dimensiones mm

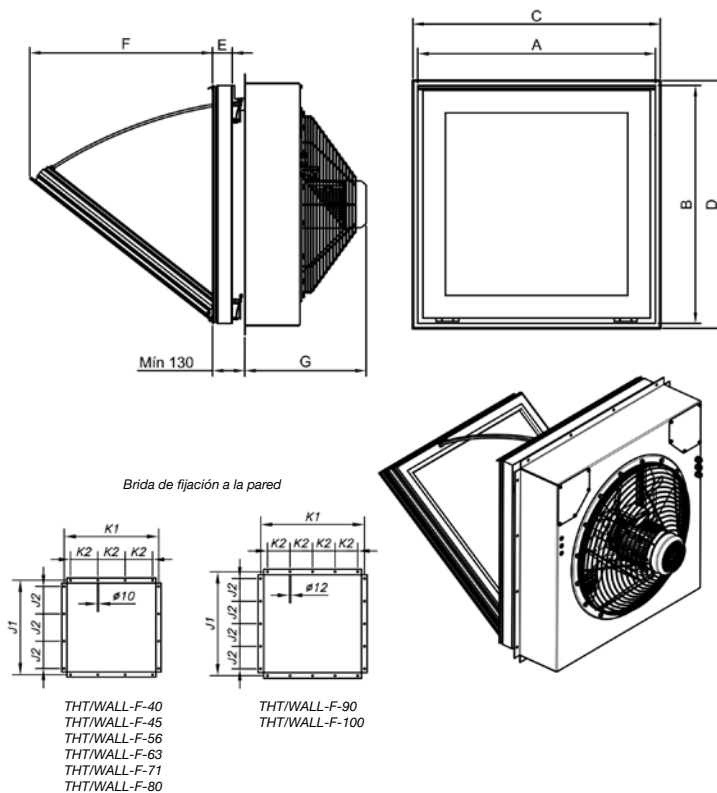

	A	B	C	D	E	F	G	J1	J2	K1	K2
THT/WALL-F-40	640	590	650	600	82	430	375	700	200	700	200
THT/WALL-F-45	640	590	650	600	82	430	400	700	200	700	200
THT/WALL-F-56	690	690	700	700	82	560	415	790	220	790	220
THT/WALL-F-63	990	990	1000	1000	82	760	475	1050	300	1050	300
THT/WALL-F-71	990	990	1000	1000	82	760	500	1050	300	1050	300
THT/WALL-F-80	990	990	1000	1000	82	760	500	1050	300	1050	300
THT/WALL-F-90	1190	1190	1200	1200	82	790	525	1250	250	1250	250
THT/WALL-F-100	1190	1190	1200	1200	82	790	550	1250	250	1250	250

(C x D) Dimensión nominal de apertura de pared.

Curvas características

Q= Caudal en m³/h, m³/s y cfm

Pe= Presión estática en mmH₂O, Pa e in wg

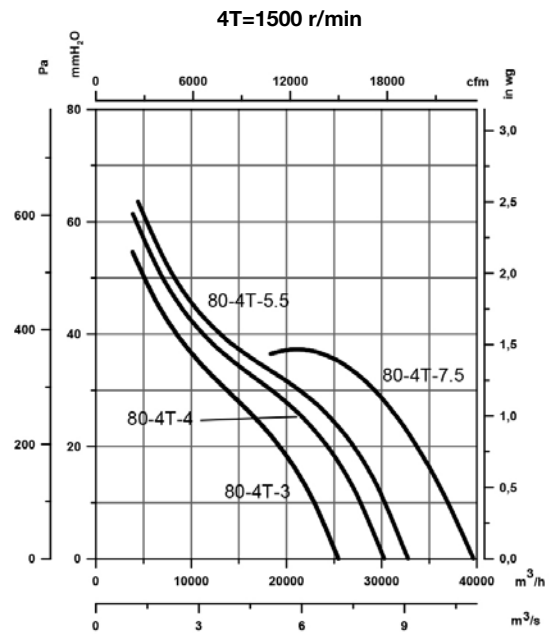
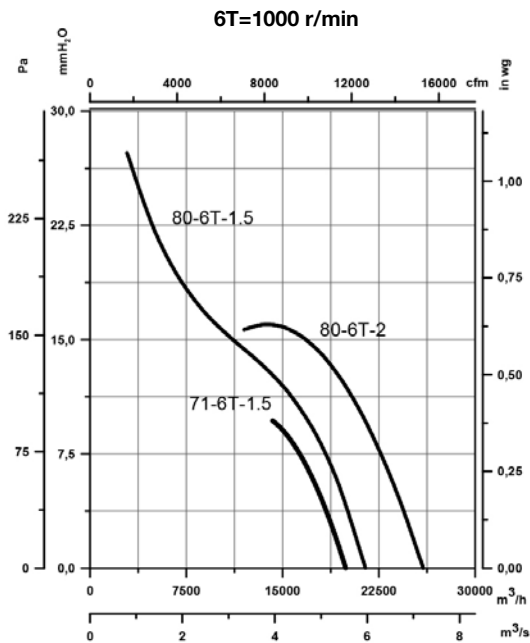
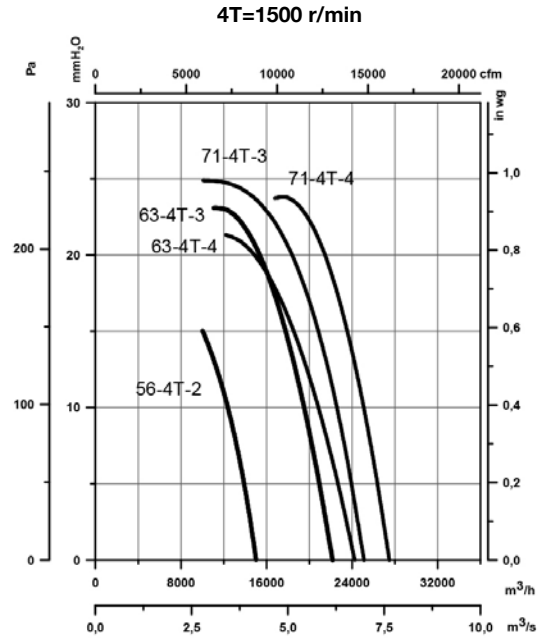
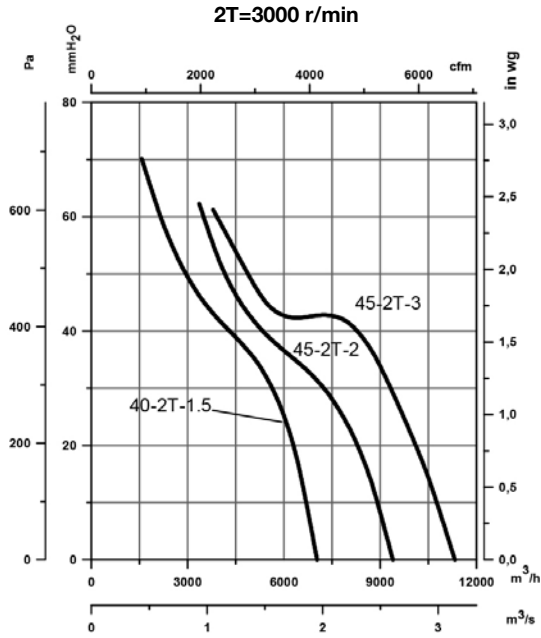

Curvas características

Q= Caudal en m³/h, m³/s y cfm

Pe= Presión estática en mmH₂O, Pa e inwg

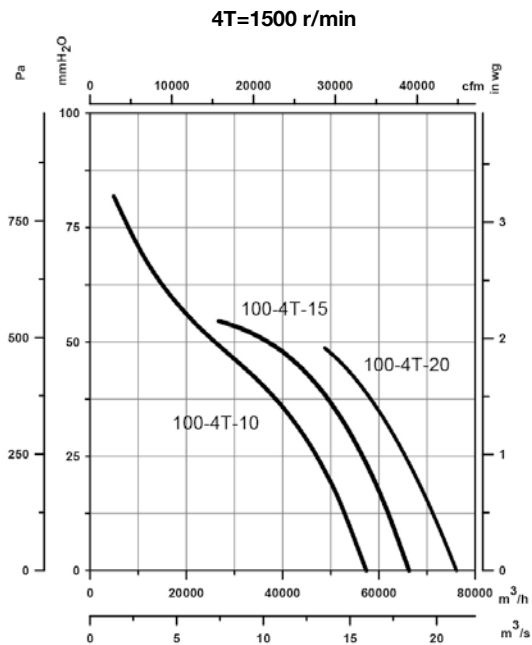
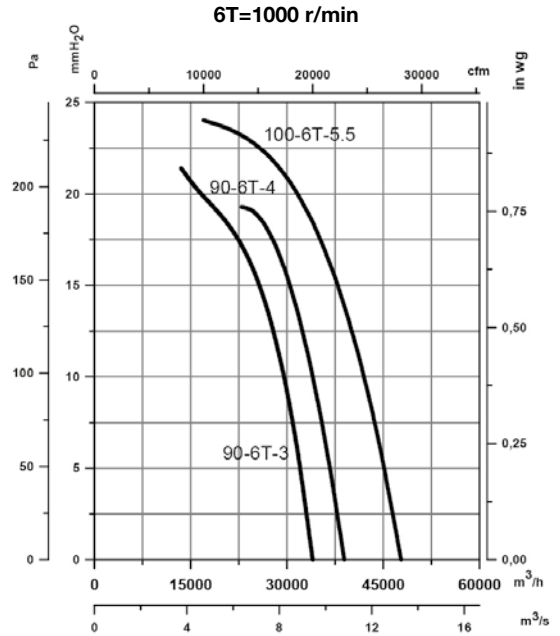
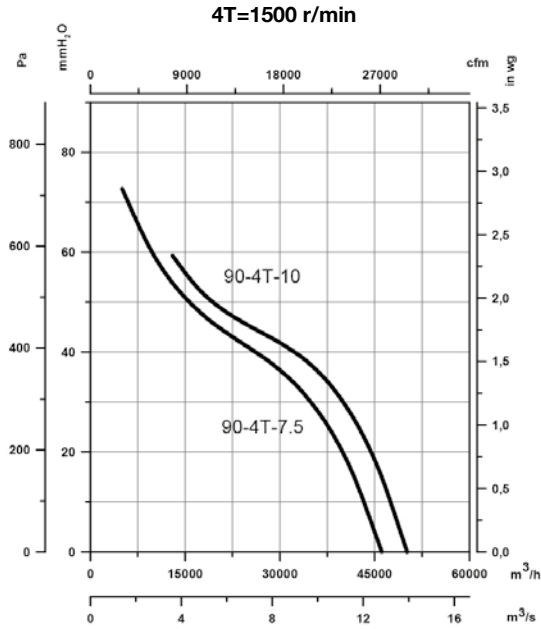

Accesorios



INT



IAT



CABLE BOX



C2V



VSD3/A-RFT
- VSD1/A-RFM



CENTRAL CO



AET



P-400



RT



R/THT



BAC



PS



ACE ACE/400



S

THT/HATCH



Exutorios dinámicos con apertura motorizada equipados con extractor de tejado, para evacuación de humo en caso de incendio 400 °C/2h y 300 °C/2h



Exutorios dinámicos con extractores de tejado, de apertura motorizada. Especialmente diseñados para la rápida y eficaz evacuación de humo y gases nocivos en caso de incendio. Apto para instalación en naves industriales o instalaciones comerciales. Homologación según norma EN 12101-3, con certificación F400 y F300. La rápida extracción del humo permite una eficaz intervención de los bomberos, una rápida evacuación de las personas evitando nuevos focos de incendio y mayores daños estructurales al edificio. Puede utilizarse también para la ventilación ambiental del edificio donde está instalado.

Ventilador:

- Estructura de gran robustez para resistir severas condiciones climáticas.
- Estructura del equipo en chapa galvanizada anticorrosiva.
- Diseñado para asegurar la estanqueidad a la entrada de agua.
- Aislamiento térmico de 100 mm de grosor para la tapa y de 60 mm para los laterales.
- Zócalo de adaptación para la correcta y fácil instalación en el tejado.
- Interruptores de mantenimiento para la desconexión del actuador y del ventilador con contactos auxiliares.
- Extractores de tejado, con certificación F400 N° 0370-CPR-1827 y F300 n° 0370-CPR-0973.
- Envoltorio tubular en chapa de acero con tratamiento anticorrosivo en resina de poliéster.
- Hélice orientable en fundición de aluminio.

Sistema de apertura:

- Brazo motorizado de apertura, con mecanismo encapsulado IP65.
- Tensión de alimentación 230 V AC 50/60 Hz.
- Sistema reforzado y garantizado con más de 11.000 ciclos.
- Carga de nieve SL 1000.
- Apertura automática mediante señal externa del sistema de control (central de incendios, detector de humos...). Sistemas de control no incluidos en el suministro.
- Interruptores final de carrera en ambas posiciones (abierto y cerrado).

Motor:

- Motores clase H para uso continuo S1 y uso emergencia S2. Con rodamientos a bolas y protección IP55.
- Motores con eficiencia IE3.
- Trifásico 230/400 V 50 Hz (hasta 3 kW) y 400/690 V 50 Hz (potencias superiores a 3 kW).
- Temperatura máxima del aire a transportar: Servicio S1 -25 °C +40 °C en continuo, apto también para climas cálidos con temperaturas hasta 50 °C. Servicio S2 300 °C/2h, 400 °C/2h.

Acabado:

- Anticorrosivo en chapa de acero galvanizado.

Bajo demanda:

- Acabado con pintura anticorrosiva en resina de poliéster.
- Brazos motorizados de apertura con tensión de alimentación 24 V DC.
- Rejilla de protección contra contactos según norma UNE-EN ISO 12499 en aspiración y/o impulsión.

Código de pedido

De tamaño 40 a tamaño 100

THT/HATCH	—	63	—	4T	—	3	—	F400
THT/HATCH: Exutorios dinámicos con apertura motorizada equipados con extractor de tejado, para evacuación de humo en caso de incendio 400 °C/2h y 300 °C/2h		Diámetro hélice en cm		Número de polos motor 2=3000 r/min 50 Hz 4=1500 r/min 50 Hz 6=1000 r/min 50 Hz	T = Trifásico	Potencia motor (CV)		F300: Homologación 300 °C/2h F400: Homologación 400 °C/2h

Código de pedido

Tamaño 125

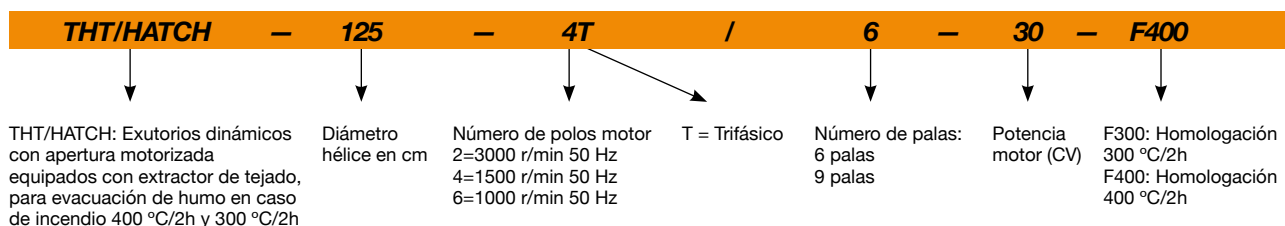

Características técnicas

Modelo	Velocidad (r/min)	Intensidad máxima admisible (A)			Potencia instalada (kW)	Ángulo inclinación palas (°)	Caudal máximo (m³/h)	Nivel presión sonora ¹ dB (A)		Peso aprox. (Kg)
		230V	400V	690V				Aspiración	Descarga	
THT/HATCH-40-2T-1 IE3	2850	2,76	1,59		0,75	16	6100	62	62	184
THT/HATCH-40-2T-1.5 IE3	2880	3,93	2,26		1,10	20	7040	61	61	188
THT/HATCH-45-2T-2 IE3	2880	4,91	2,84		1,50	16	9400	61	61	193
THT/HATCH-45-2T-3 IE3	2840	7,14	4,13		2,20	22	11325	61	61	194
THT/HATCH-50-2T-4 IE3	2880	9,61	5,52		3,00	16	13860	66	66	206
THT/HATCH-56-2T-5.5 IE3	2870		7,20	4,17	4,00	16	18820	68	68	226
THT/HATCH-56-2T-7.5 IE3	2910		10,10	5,80	5,50	22	22510	68	68	237
THT/HATCH-63-4T-3 IE3	1425	7,86	4,52		2,20	32	22170	58	58	262
THT/HATCH-63-4T-4 IE3	1430	11,01	6,33		3,00	38	24240	59	59	271
THT/HATCH-63-6T-1 IE3	940	3,36	1,93		0,75	38	15890	48	48	252
THT/HATCH-80-4T-3 IE3	1425	7,86	4,52		2,20	12	25460	65	65	280
THT/HATCH-80-4T-4 IE3	1430	11,01	6,33		3,00	16	30270	64	64	289
THT/HATCH-80-4T-5.5 IE3	1440		7,95	4,61	4,00	18	32770	63	63	295
THT/HATCH-80-4T-7.5 IE3	1460		10,40	6,04	5,50	26	39640	63	63	311
THT/HATCH-80-6T-1.5 IE3	945	4,73	2,72		1,10	18	21470	53	53	279
THT/HATCH-80-6T-2 IE3	945	6,25	3,62		1,50	26	25970	54	54	288
THT/HATCH-90-4T-7.5 IE3	1460		10,40	6,04	5,50	18	46140	67	67	392
THT/HATCH-90-4T-10 IE3	1460		14,20	8,17	7,50	22	50140	66	66	403
THT/HATCH-90-4T-15 IE3	1460		20,70	11,99	11,00	30	59390	68	68	456
THT/HATCH-90-6T-3 IE3	950	9,78	5,62		2,20	24	34000	56	56	365
THT/HATCH-90-6T-4 IE3	970	12,80	6,36		3,00	30	38910	59	59	391
THT/HATCH-100-4T-10 IE3	1460		14,20	8,17	7,50	16	57420	69	69	413
THT/HATCH-100-4T-15 IE3	1460		20,70	11,99	11,00	22	66300	69	69	466
THT/HATCH-100-4T-20 IE3	1460		27,80	16,03	15,00	28	76160	70	70	481
THT/HATCH-100-4T/9-25 IE3	1475		35,40	20,39	18,50	26	70620	69	69	535
THT/HATCH-100-4T/9-30 IE3	1475		42,20	24,44	22,00	30	74840	71	71	552
THT/HATCH-100-6T-5.5 IE3	970		8,37	4,82	4,00	26	47780	60	60	413
THT/HATCH-100-6T-7.5 IE3	970		12,30	7,07	5,50	32	53520	62	62	420
THT/HATCH-125-4T/6-25 IE3	1465		35,40	20,39	18,50	14	92550	76	76	746
THT/HATCH-125-4T/6-30 IE3	1470		42,20	24,44	22,00	16	98830	75	75	760
THT/HATCH-125-4T/6-40 IE3	1475		53,30	31,02	30,00	22	117450	75	75	841
THT/HATCH-125-4T/6-50 IE3	1480		66,80	38,70	37,00	26	131050	75	75	889
THT/HATCH-125-4T/9-25 IE3	1465		35,40	20,39	18,50	10	79650	77	77	755
THT/HATCH-125-4T/9-30 IE3	1470		42,20	24,44	22,00	12	88290	76	76	769
THT/HATCH-125-4T/9-40 IE3	1475		53,30	31,02	30,00	16	104040	75	75	850
THT/HATCH-125-4T/9-50 IE3	1480		66,80	38,70	37,00	20	118400	75	75	898
THT/HATCH-125-6T/6-5.5 IE3	970		8,37	4,82	4,00	10	51500	67	67	611
THT/HATCH-125-6T/6-7.5 IE3	970		12,30	7,07	5,50	14	60640	65	65	618
THT/HATCH-125-6T/6-10 IE3	960		15,20	8,83	7,50	20	72650	64	64	643
THT/HATCH-125-6T/6-15 IE3	955		22,50	13,07	11,00	26	85850	64	64	673

Características técnicas

Modelo	Velocidad (r/min)	Intensidad máxima admisible (A)			Potencia instalada (kW)	Ángulo inclinación palas (°)	Caudal máximo (m³/h)	Nivel presión sonora ¹ dB (A)		Peso aprox. (Kg)
		230V	400V	690V				Aspiración	Descarga	
THT/HATCH-125-6T/6-20 IE3	950		29,00	16,78	15,00	30	92850	66	66	746
THT/HATCH-125-6T/9-10 IE3	960		15,20	8,83	7,50	14	63490	67	67	652
THT/HATCH-125-6T/9-15 IE3	955		22,50	13,07	11,00	20	77550	65	65	682
THT/HATCH-125-6T/9-20 IE3	950		29,00	16,78	15,00	26	92950	65	65	755

¹ Los valores de los niveles sonoros, son presiones en dB(A) medidos a 10 metros, en campo libre.

Características técnicas del exutorio dinámico según normas EN-12101-3 y EN-12101-2

Modelo	Homologación (°C)	Clase aislamiento motor	Durabilidad	Temperatura ambiente mínima (°C)	Carga de viento (Pa)	Carga de nieve (Pa)



Erp. (Energy Related Products)

Información de la Directiva 2009/125/EC descargable desde la web de SODECA o programa de selección QuickFan.

Características acústicas

Espectro de potencia sonora Lw(A) en dB(A) por banda de frecuencia en Hz

Valores tomados a la aspiración con caudal máximo

	63	125	250	500	1000	2000	4000	8000
40-2-1	48	64	76	84	89	87	83	76
40-2-1.5	47	63	75	83	88	86	82	75
45-2-2	47	60	74	86	87	86	82	74
45-2-3	47	64	74	81	88	86	83	75
50-2-4	58	74	84	91	92	89	88	89
56-2-5.5	53	66	84	92	94	93	88	81
56-2-7.5	53	66	84	92	94	93	88	81
63-4-3	56	68	77	83	83	83	77	69
63-4-4	57	69	78	84	84	84	78	70
63-6-1	49	59	69	73	74	72	65	57
80-4-3	55	71	84	91	91	88	82	74
80-4-4	54	70	83	90	90	87	81	73
80-4-5.5	53	69	82	89	89	86	80	72
80-4-7.5	53	69	82	89	89	86	80	72
80-6-1.5	53	68	75	78	79	76	70	62
80-6-2	59	69	75	79	80	78	73	65
90-4-7.5	59	75	86	92	93	91	86	78
90-4-10	58	74	85	91	92	90	85	77
90-4-15	60	76	87	93	94	92	87	79
90-6-3	52	67	78	82	82	78	71	63
90-6-4	60	70	80	85	85	82	76	68
100-4-10	64	80	87	94	95	93	89	81
100-4-15	71	83	87	93	94	94	91	83
100-4-20	72	84	88	94	95	95	92	84
100-4/9-25	71	83	87	93	94	94	91	83
100-4/9-30	73	85	89	95	96	96	93	85
100-6-5.5	57	72	82	85	86	83	75	67
100-6-7.5	59	74	84	87	88	85	77	69
125-4/6-25	68	84	95	102	103	101	94	86
125-4/6-30	67	83	94	101	102	100	93	85
125-4/6-40	67	83	94	101	102	100	93	85
125-4/6-50	67	83	94	101	102	100	93	85
125-4/9-25	67	81	94	102	104	101	96	88
125-4/9-30	66	80	93	101	103	100	95	87
125-4/9-40	65	79	92	100	102	99	94	86
125-4/9-50	65	79	92	100	102	99	94	86

Valores tomados a la descarga con caudal máximo

	63	125	250	500	1000	2000	4000	8000
40-2-1	48	64	76	84	89	87	83	76
40-2-1.5	47	63	75	83	88	86	82	75
45-2-2	47	60	74	86	87	86	82	74
45-2-3	47	64	74	81	88	86	83	75
50-2-4	58	74	84	91	92	89	88	89
56-2-5.5	53	66	84	92	94	93	88	81
56-2-7.5	53	66	84	92	94	93	88	81
63-4-3	56	68	77	83	83	83	77	69
63-4-4	57	69	78	84	84	84	78	70
63-6-1	49	59	69	73	74	72	65	57
80-4-3	55	71	84	91	91	88	82	74
80-4-4	54	70	83	90	90	87	81	73
80-4-5.5	53	69	82	89	89	86	80	72
80-4-7.5	53	69	82	89	89	86	80	72
80-6-1.5	53	68	75	78	79	76	70	62
80-6-2	59	69	75	79	80	78	73	65
90-4-7.5	59	75	86	92	93	91	86	78
90-4-10	58	74	85	91	92	90	85	77
90-4-15	60	76	87	93	94	92	87	79
90-6-3	52	67	78	82	82	78	71	63
90-6-4	60	70	80	85	85	82	76	68
100-4-10	64	80	87	94	95	93	89	81
100-4-15	71	83	87	93	94	94	91	83
100-4-20	72	84	88	94	95	95	92	84
100-4/9-25	71	83	87	93	94	94	91	83
100-4/9-30	73	85	89	95	96	96	93	85
100-6-5.5	57	72	82	85	86	83	75	67
100-6-7.5	59	74	84	87	88	85	77	69
125-4/6-25	68	84	95	102	103	101	94	86
125-4/6-30	67	83	94	101	102	100	93	85
125-4/6-40	67	83	94	101	102	100	93	85
125-4/6-50	67	83	94	101	102	100	93	85
125-4/9-25	67	81	94	102	104	101	96	88
125-4/9-30	66	80	93	101	103	100	95	87
125-4/9-40	65	79	92	100	102	99	94	86
125-4/9-50	65	79	92	100	102	99	94	86

Características acústicas

Espectro de potencia sonora Lw(A) en dB(A) por banda de frecuencia en Hz

Valores tomados a la aspiración con caudal máximo

	63	125	250	500	1000	2000	4000	8000
125-6/6-5.5	64	79	89	92	93	90	85	77
125-6/6-7.5	62	77	87	90	91	88	83	75
125-6/6-10	61	76	86	89	90	87	82	74
125-6/6-15	61	76	86	89	90	87	82	74
125-6/6-20	63	78	88	91	92	89	84	76
125-6/9-10	61	76	87	93	94	88	84	77
125-6/9-15	59	74	85	91	92	86	82	75
125-6/9-20	59	74	85	91	92	86	82	75

Valores tomados a la descarga con caudal máximo

	63	125	250	500	1000	2000	4000	8000
125-6/6-5.5	64	79	89	92	93	90	85	77
125-6/6-7.5	62	77	87	90	91	88	83	75
125-6/6-10	61	76	86	89	90	87	82	74
125-6/6-15	61	76	86	89	90	87	82	74
125-6/6-20	63	78	88	91	92	89	84	76
125-6/9-10	61	76	87	93	94	88	84	77
125-6/9-15	59	74	85	91	92	86	82	75
125-6/9-20	59	74	85	91	92	86	82	75

Dimensiones mm

THT/HATCH-40...100

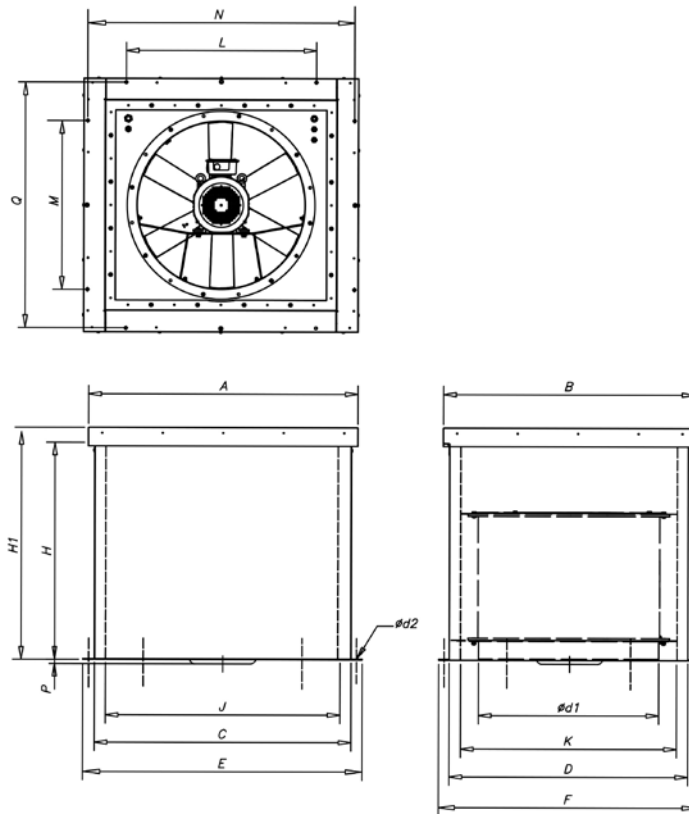

	A	B	C	D	ød1	ød2	E	F	H	H1	J	K	L	M	N	P	Q
THT/HATCH-40	1100	1000	1020	920	400	13	1100	1000	900	1000	900	800	700	600	1065	-	965
THT/HATCH-45	1100	1000	1020	920	450	13	1100	1000	900	1000	900	800	700	600	1065	-	965
THT/HATCH-50	1100	1000	1020	920	500	13	1100	1000	900	1000	900	800	700	600	1065	-	965
THT/HATCH-56	1100	1000	1020	920	560	13	1100	1000	900	1000	900	800	700	600	1065	-	965
THT/HATCH-63	1300	1200	1220	1120	630	13	1300	1200	900	1000	1100	1000	900	800	1265	-	1165
THT/HATCH-80	1300	1200	1220	1120	800	13	1300	1200	900	1000	1100	1000	900	800	1265	-	1165
THT/HATCH-90	1500	1400	1420	1320	900	13	1500	1400	900	1000	1300	1200	1100	1000	1465	-	1365
THT/HATCH-90-4T-15	1500	1400	1420	1320	900	13	1500	1400	900	1000	1300	1200	1100	1000	1465	38	1365
THT/HATCH-100	1500	1400	1420	1320	1000	13	1500	1400	900	1000	1300	1200	1100	1000	1465	-	1365
THT/HATCH-100-4T-15	1500	1400	1420	1320	1000	13	1500	1400	900	1000	1300	1200	1100	1000	1465	80	1365
THT/HATCH-100-4T-20	1500	1400	1420	1320	1000	13	1500	1400	900	1000	1300	1200	1100	1000	1465	80	1365
THT/HATCH-100-4T/9-25	1500	1400	1420	1320	1000	13	1500	1400	900	1000	1300	1200	1100	1000	1465	125	1365
THT/HATCH-100-4T/9-30	1500	1400	1420	1320	1000	13	1500	1400	900	1000	1300	1200	1100	1000	1465	125	1365

Dimensiones mm

THT/HATCH-125

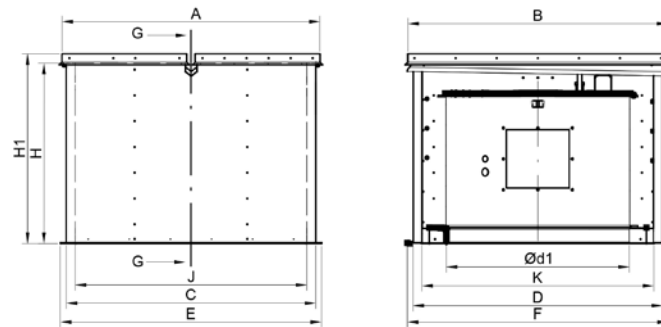

	A	B	C	D	Ød1	E	F	H	H1	J	K
THT/HATCH-125	1750	1775	1700	1700	1245	1780	1780	1230	1330	1580	1580

Esquema instalación

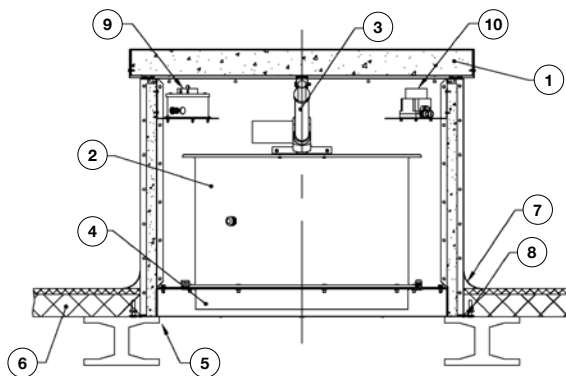

1. Caja THT/HATCH
2. Ventilador THT
3. Brazo motorizado (230 V AC o 24 V DC x2)
4. Brida de conexión conducto aspiración
5. Abertura tejado
6. Cubierta
7. Protección contra la filtración de agua
8. Montaje directo usando el zócalo de adaptación
9. Interruptor seguridad motor
10. Interruptor seguridad actuador

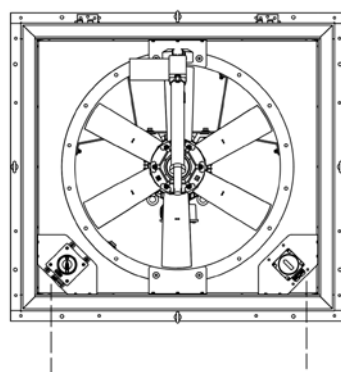

Alimentación motor
3x400 V 50 Hz

Alimentación actuador
1x230 V 50 Hz o 24 V DC

--- A realizar por el instalador

Nota: Para motores superiores a 5,5 kW es aconsejable utilizar arrancador electrónico.

Curvas características

Q= Caudal en m³/h, m³/s y cfm

Pe= Presión estática en mmH₂O, Pa e inwg

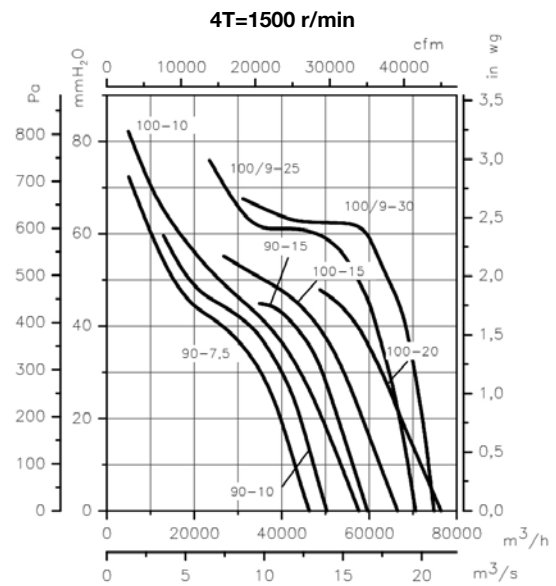
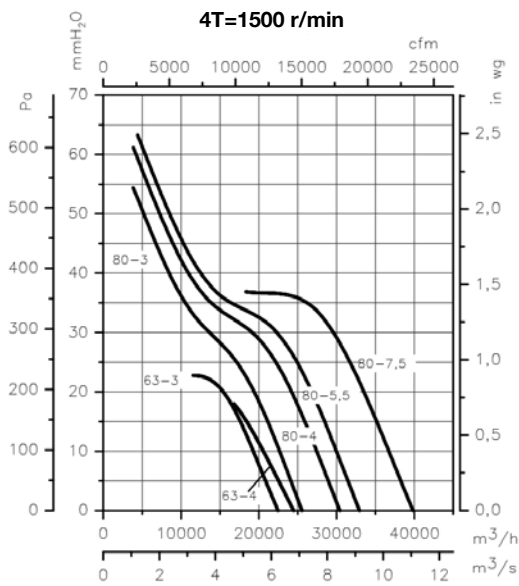
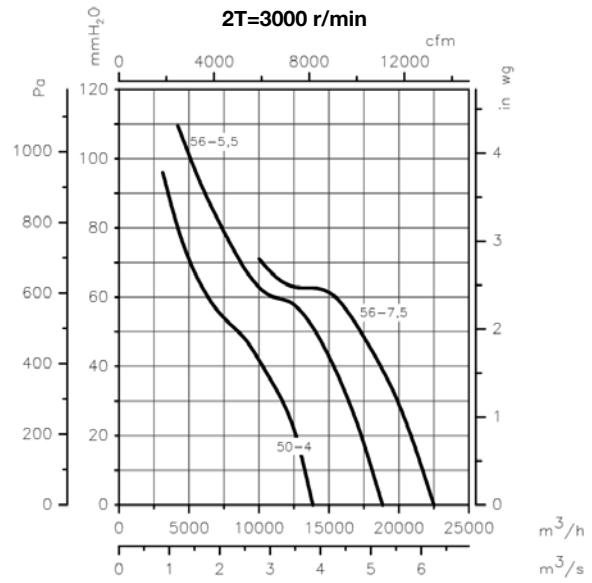
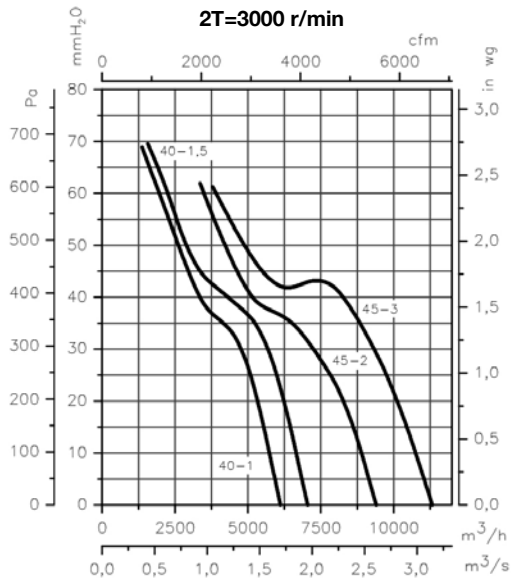

Curvas características

Q= Caudal en m³/h, m³/s y cfm

Pe= Presión estática en mmH₂O, Pa e inwg

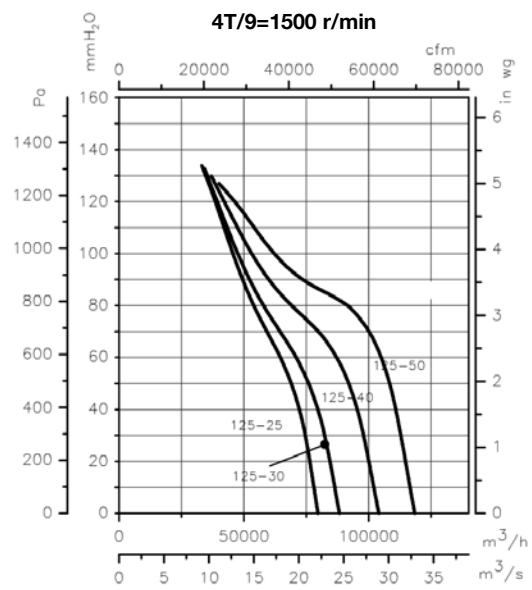
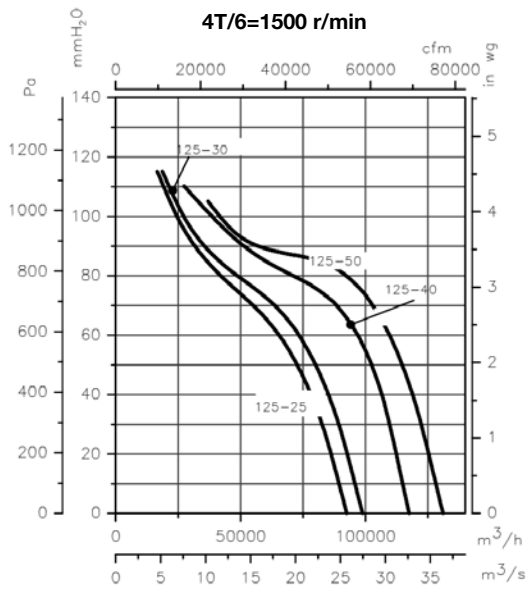
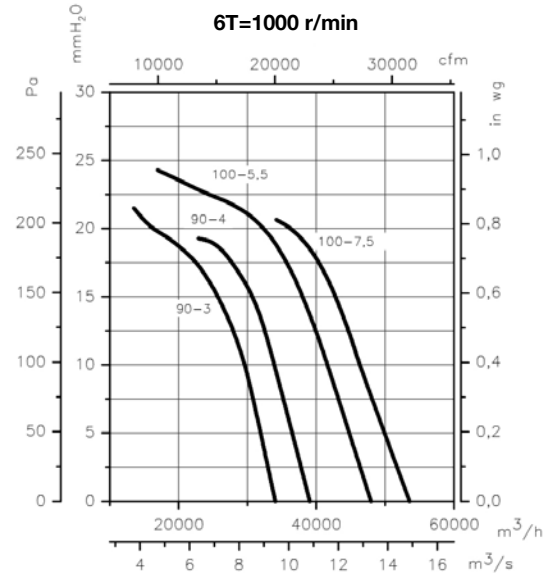
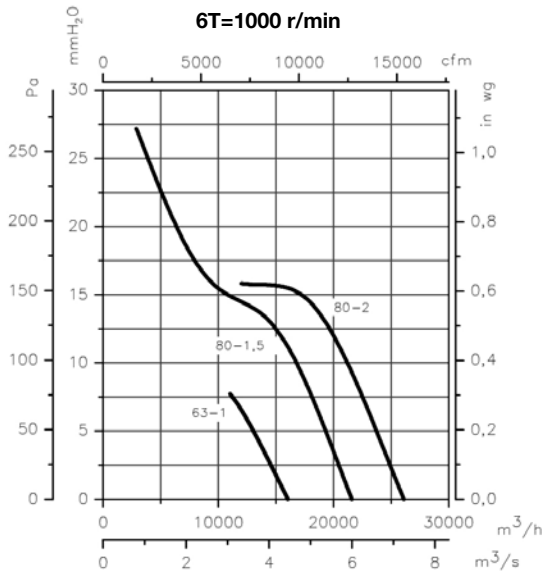

Curvas características

Q= Caudal en m³/h, m³/s y cfm

Pe= Presión estática en mmH₂O, Pa e inwg

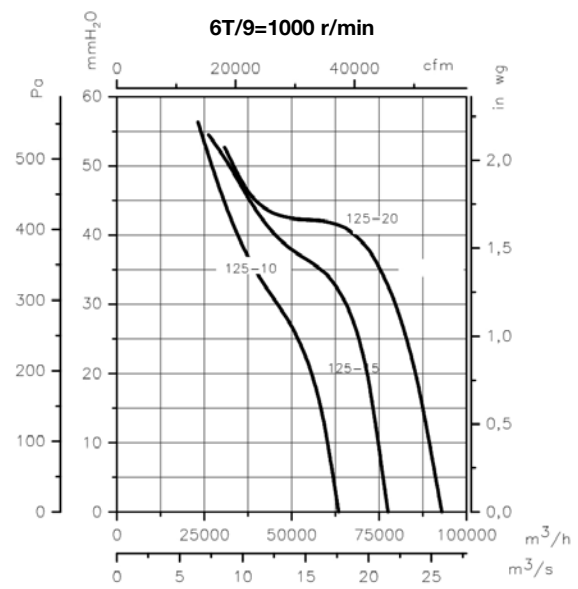
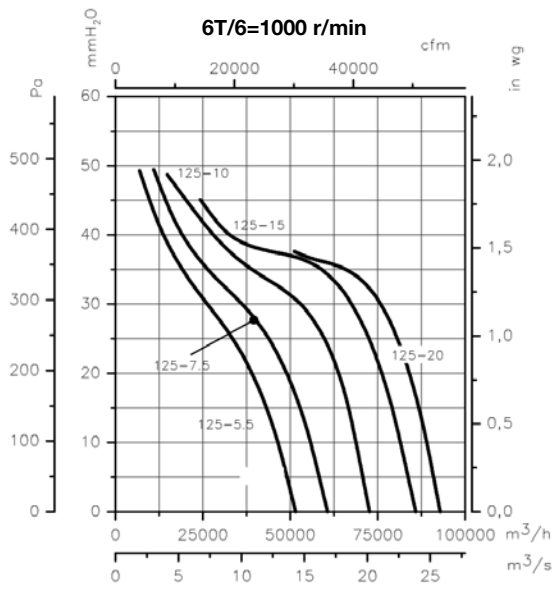

CJTHT/PLUS

Unidades de extracción helicoidales 400 °C/2h y 300 °C/2h con atenuador acústico integrado



Unidades de extracción con ventiladores helicoidales para trabajar inmersas en zonas de riesgo de incendios.

Ventilador:

- Ventilador con envolvente tubular en chapa de acero.
- Estructura en chapa de acero galvanizado, con aislamiento térmico y acústico.
- Hélice de ángulo variable en fundición de aluminio.
- Homologación según norma EN 12101-3, con certificaciones n°: 0370-CPR-0312 (F400) y 0370-CPR-0974 (F300).

Motor:

- Motores clase H para uso continuo S1 y uso emergencia S2. Con rodamientos a bolas, protección IP55 y 1 o 2 velocidades según modelo.
- Motores con eficiencia IE3 para potencias iguales o superiores a 0,75 kW, excepto monofásicos, 2 velocidades y 8 polos.
- Trifásico 230/400 V 50 Hz (hasta 3 kW) y 400/690 V 50 Hz (potencias superiores a 3 kW).

- Temperatura máxima del aire a transportar: Servicio S1 -20 °C +40 °C en continuo, apto también para climas cálidos con temperaturas hasta 50 °C. Servicio S2 300 °C/2h, 400 °C/2h.

Acabado:

- Ventilador: Anticorrosivo en resina de poliéster polimerizada a 190 °C, previo desengrase con tratamiento nanotecnológico libre de fosfatos.
- Caja: anticorrosivo en chapa de acero galvanizado.

Versiones disponibles:

- CJTHT: Ventiladores helicoidales con caja aislada acústicamente.
- CJTHT/ATEX: Ventiladores helicoidales con caja aislada acústicamente, con certificación ATEX, categoría 3 Ex II3G para zona 2 (sólo 400 °C/2h y 300 °C/2h).
- CJTHT/PLUS: Ventiladores helicoidales con atenuador acústico.

Bajo demanda:

- Dirección aire hélice-motor.
- Hélices reversibles 100%.

Código de pedido

CJTHT/PLUS	-	56	-	4T	-	2	-	F400
↓		↓		↓		↓		↓
CJTHT/PLUS: Unidades de extracción helicoidales 400 °C/2h y 300 °C/2h con atenuador acústico integrado		Diámetro hélice en cm		Número de polos motor 2=3000 r/min 50 Hz 4=1500 r/min 50 Hz 6=1000 r/min 50 Hz 8=750 r/min 50 Hz 12=500 r/min 50 Hz	T = Trifásico	Potencia motor (CV)		F300: Homologación 300 °C/2h F400: Homologación 400 °C/2h

Características técnicas

Modelo	Velocidad (r/min)	Intensidad máxima admisible (A)			Potencia instalada (kW)	Ángulo inclinación palas (°)	Caudal máximo (m³/h)	Nivel presión sonora ¹ dB (A) Aspiración	Peso aprox. (Kg)
		230V	400V	690V					
CJTHT/PLUS-40-2/4T-1.5	2900 / 1435		2,89 / 1,04		1,10 / 0,25	20	7040 / 3480	71 / 56	53
CJTHT/PLUS-40-4T-0.75	1420	2,84	1,64		0,55	32	4800	55	47
CJTHT/PLUS-40-6T-0.75	930	2,90	1,75		0,55	32	3150	46	52
CJTHT/PLUS-40-6/12T-0.75	940 / 455		2,35 / 1,15		0,60 / 0,15	32	3150 / 1520	46 / 31	56
CJTHT/PLUS-45-2/4T-2	2940 / 1465		3,58 / 1,19		1,50 / 0,37	16	9400 / 4680	71 / 56	56
CJTHT/PLUS-45-4T-0.75	1420	2,84	1,64		0,55	36	7450	58	49
CJTHT/PLUS-45-6T-0.75	930	2,90	1,75		0,55	30	4450	48	53
CJTHT/PLUS-45-6/12T-0.75	940 / 455		2,35 / 1,15		0,60 / 0,15	30	4450 / 2150	48 / 33	58
CJTHT/PLUS-50-4T-0.75	1420	2,84	1,64		0,55	22	8392	60	50

Características técnicas

Modelo	Velocidad (r/min)	Intensidad máxima admisible (A)			Potencia instalada (kW)	Ángulo inclinación palas (°)	Caudal máximo (m³/h)	Nivel presión sonora¹ dB (A) Aspiración	Peso aprox. (Kg)
		230V	400V	690V					
CJTHT/PLUS-50-6T-0.75	930	2,90	1,75		0,55	32	7000	52	55
CJTHT/PLUS-56-4T-1 IE3	1430	3,08	1,79		0,75	22	11250	63	62
CJTHT/PLUS-56-4T-1.5 IE3	1420	4,10	2,37		1,10	30	13600	63	64
CJTHT/PLUS-56-4/8T-1.5	1440 / 705		2,69 / 1,12		1,10 / 0,25	30	13600 / 6640	63 / 48	68
CJTHT/PLUS-56-4T-2 IE3	1425	5,89	3,38		1,50	36	15030	64	68
CJTHT/PLUS-56-6T-0.75	930	2,90	1,75		0,55	38	10140	54	64
CJTHT/PLUS-56-6/12T-0.75	940 / 455		2,35 / 1,15		0,60 / 0,15	38	10140 / 4890	54 / 39	68
CJTHT/PLUS-63-4T-1 IE3	1430	3,08	1,79		0,75	14	15190	67	66
CJTHT/PLUS-63-4T-1.5 IE3	1420	4,10	2,37		1,10	20	17800	66	69
CJTHT/PLUS-63-4/8T-1.5	1440 / 705		2,69 / 1,12		1,10 / 0,25	20	17800 / 8680	66 / 51	72
CJTHT/PLUS-63-4T-2 IE3	1425	5,89	3,38		1,50	24	19280	66	72
CJTHT/PLUS-63-4/8T-2	1415 / 715		3,40 / 1,65		1,50 / 0,30	24	19280 / 9740	66 / 52	84
CJTHT/PLUS-63-4T-3 IE3	1435	7,86	4,52		2,20	32	22150	68	78
CJTHT/PLUS-63-4/8T-3	1415 / 700		4,80 / 1,85		2,20 / 0,45	32	22150 / 10920	68 / 53	90
CJTHT/PLUS-63-4T-4 IE3	1430	11,01	6,33		3,00	38	24240	69	87
CJTHT/PLUS-63-4/8T-4	1420 / 710		6,45 / 2,28		3,00 / 0,60	38	24240 / 12070	69 / 54	101
CJTHT/PLUS-63-6T-0.75	930	2,90	1,75		0,55	28	13590	57	68
CJTHT/PLUS-63-6/12T-0.75	940 / 455		2,35 / 1,15		0,60 / 0,15	28	13590 / 6550	57 / 42	72
CJTHT/PLUS-63-6T-1 IE3	940	3,36	1,93		0,75	38	15890	58	72
CJTHT/PLUS-63-6/12T-1	935 / 455		3,75 / 2,76		0,80 / 0,20	38	15890 / 7700	58 / 43	78
CJTHT/PLUS-71-4T-1.5 IE3	1420	4,10	2,37		1,10	12	19480	71	85
CJTHT/PLUS-71-4/8T-1.5	1440 / 705		2,69 / 1,12		1,10 / 0,25	12	19480 / 9500	71 / 56	89
CJTHT/PLUS-71-4T-2 IE3	1425	5,89	3,38		1,50	14	20900	70	89
CJTHT/PLUS-71-4/8T-2	1415 / 715		3,40 / 1,65		1,50 / 0,30	14	20900 / 10560	70 / 56	101
CJTHT/PLUS-71-4T-3 IE3	1435	7,86	4,52		2,20	22	25100	70	95
CJTHT/PLUS-71-4/8T-3	1415 / 700		4,80 / 1,85		2,20 / 0,45	22	25100 / 12370	70 / 55	107
CJTHT/PLUS-71-4T-4 IE3	1430	11,01	6,33		3,00	28	27480	70	104
CJTHT/PLUS-71-4/8T-4	1420 / 710		6,45 / 2,28		3,00 / 0,60	28	27480 / 13680	70 / 55	118
CJTHT/PLUS-71-6T-0.75	930	2,90	1,75		0,55	20	16100	60	85
CJTHT/PLUS-71-6/12T-0.75	940 / 455		2,35 / 1,15		0,60 / 0,15	20	16100 / 7760	60 / 45	89
CJTHT/PLUS-71-6T-1 IE3	940	3,36	1,93		0,75	26	17300	60	88
CJTHT/PLUS-71-6/12T-1	935 / 455		3,75 / 2,76		0,80 / 0,20	26	17300 / 8380	60 / 45	95
CJTHT/PLUS-71-6T-1.5 IE3	945	4,73	2,72		1,10	34	19930	61	94
CJTHT/PLUS-71-6/12T-1.5	940 / 460		3,52 / 2,00		1,20 / 0,30	34	19930 / 9760	61 / 46	102
CJTHT/PLUS-80-4T-3 IE3	1435	7,86	4,52		2,20	12	25450	75	103
CJTHT/PLUS-80-4/8T-3	1415 / 700		4,80 / 1,85		2,20 / 0,45	12	25450 / 12550	75 / 60	115
CJTHT/PLUS-80-4T-4 IE3	1430	11,01	6,33		3,00	16	30250	74	112
CJTHT/PLUS-80-4/8T-4	1420 / 710		6,45 / 2,28		3,00 / 0,60	16	30250 / 15060	74 / 59	125
CJTHT/PLUS-80-4T-5.5 IE3	1440		7,95	4,61	4,00	18	32750	73	118
CJTHT/PLUS-80-4/8T-5.5	1450 / 715		7,88 / 2,87		3,80 / 1,00	18	32750 / 16150	73 / 58	153
CJTHT/PLUS-80-6T-1.5 IE3	945	4,73	2,72		1,10	18	21450	63	102
CJTHT/PLUS-80-6/12T-1.5	940 / 460		3,52 / 2,00		1,20 / 0,30	18	21450 / 10500	63 / 48	110
CJTHT/PLUS-80-6T-2 IE3	945	6,25	3,62		1,50	26	25950	64	111
CJTHT/PLUS-80-6/12T-2	960 / 470		4,46 / 3,43		1,60 / 0,40	26	25950 / 12700	64 / 49	115
CJTHT/PLUS-80-6T-3 IE3	950	9,78	5,62		2,20	32	29930	65	118
CJTHT/PLUS-80-6/12T-3	940 / 475		5,62 / 3,32		2,20 / 0,55	32	29930 / 15120	65 / 51	124
CJTHT/PLUS-80-8T-0.75	700	3,48	2,00		0,55	20	17540	57	95
CJTHT/PLUS-80-8T-1	710	5,06	2,92		0,75	28	20650	58	102
CJTHT/PLUS-90-4T-4 IE3	1430	11,01	6,33		3,00	8	33580	79	136
CJTHT/PLUS-90-4/8T-4	1420 / 710		6,45 / 2,28		3,00 / 0,60	8	33580 / 16720	79 / 64	149
CJTHT/PLUS-90-4T-5.5 IE3	1440		7,95	4,61	4,00	12	38890	78	142
CJTHT/PLUS-90-4/8T-5.5	1450 / 715		7,88 / 2,87		3,80 / 1,00	12	38890 / 19170	78 / 63	177
CJTHT/PLUS-90-4T-7.5 IE3	1430		10,40	6,04	5,50	18	46140	77	168
CJTHT/PLUS-90-4/8T-7.5	1455 / 725		11,40 / 3,86		5,50 / 1,10	18	46140 / 22910	77 / 62	182
CJTHT/PLUS-90-4T-10 IE3	1460		14,20	8,17	7,50	22	50140	76	179

Características técnicas

Modelo	Velocidad (r/min)	Intensidad máxima admisible (A)			Potencia instalada (kW)	Ángulo inclinación palas (°)	Caudal máximo (m³/h)	Nivel presión sonora¹ dB (A) Aspiración	Peso aprox. (Kg)
		230V	400V	690V					
CJTHT/PLUS-90-4/8T-10	1455 / 725		15,10 / 5,16		7,50 / 1,50	22	50140 / 24900	76 / 61	182
CJTHT/PLUS-90-6T-2 IE3	945	6,25	3,62		1,50	16	28780	66	135
CJTHT/PLUS-90-6/12T-2	960 / 470		4,46 / 3,43		1,60 / 0,40	16	28780 / 14090	66 / 51	139
CJTHT/PLUS-90-6T-3 IE3	950	9,78	5,62		2,20	24	34000	66	142
CJTHT/PLUS-90-6/12T-3	940 / 475		5,62 / 3,32		2,20 / 0,55	24	34000 / 17180	66 / 52	148
CJTHT/PLUS-90-6T-4 IE3	945	12,80	6,36		3,00	30	38900	69	166
CJTHT/PLUS-90-6/12T-4	970 / 485		7,37 / 3,53		2,80 / 0,70	30	38900 / 19450	69 / 54	168
CJTHT/PLUS-90-8T-1	710	5,06	2,92		0,75	18	22900	60	126
CJTHT/PLUS-90-8T-2	700	7,32	4,21		1,50	30	29490	63	142
CJTHT/PLUS-90-8T-3	705	9,30	5,35		2,20	32	30850	64	158
CJTHT/PLUS-100-4T-7.5 IE3	1430		10,40	6,04	5,50	10	46850	82	176
CJTHT/PLUS-100-4/8T-7.5	1455 / 725		11,40 / 3,86		5,50 / 1,10	10	46850 / 23260	82 / 67	190
CJTHT/PLUS-100-4T-10 IE3	1460		14,20	8,17	7,50	16	57400	79	187
CJTHT/PLUS-100-4/8T-10	1455 / 725		15,10 / 5,16		7,50 / 1,50	14	54710 / 27170	80 / 65	190
CJTHT/PLUS-100-4T-15 IE3	1455		20,70	11,99	11,00	22	66300	79	231
CJTHT/PLUS-100-4/8T-15	1470 / 730		20,70 / 7,19		11,00 / 3,00	22	66300 / 32880	79 / 64	231
CJTHT/PLUS-100-4T-20 IE3	1460		27,80	16,03	15,00	28	76150	80	246
CJTHT/PLUS-100-4/8T-20	1470 / 725		31,72 / 11,75		15,00 / 3,80	28	76150 / 37560	80 / 65	246
CJTHT/PLUS-100-4T/9-15 IE3	1460		20,70	11,99	11,00	18	55340	80	231
CJTHT/PLUS-100-4T/9-20 IE3	1460		27,80	16,03	15,00	22	63260	80	240
CJTHT/PLUS-100-4T/9-25 IE3	1475		35,40	20,39	18,50	26	70625	80	280
CJTHT/PLUS-100-4T/9-30 IE3	1475		42,20	24,44	22,00	30	74845	82	288
CJTHT/PLUS-100-6T-3 IE3	950	9,78	5,62		2,20	16	37600	70	150
CJTHT/PLUS-100-6/12T-3	940 / 475		5,62 / 3,32		2,20 / 0,55	16	37600 / 18990	70 / 56	156
CJTHT/PLUS-100-6T-4 IE3	945	12,80	6,36		3,00	20	41150	69	175
CJTHT/PLUS-100-6/12T-4	970 / 485		7,37 / 3,53		2,80 / 0,70	20	41150 / 20580	69 / 54	176
CJTHT/PLUS-100-6T-5.5 IE3	970		8,37	4,82	4,00	26	47780	70	187
CJTHT/PLUS-100-6T/9-5.5 IE3	970		11,00	6,35	4,00	20	39020	70	201
CJTHT/PLUS-100-6T/9-7.5 IE3	970		12,30	7,07	5,50	26	46765	71	205
CJTHT/PLUS-100-6T/9-10 IE3	970		15,20	8,83	7,50	34	52255	74	230

1 Los valores de los niveles sonoros, son presiones en dB(A) medidos a 3 metros, en campo libre.



Erp. (Energy Related Products)

Información de la Directiva 2009/125/EC descargable desde la web de SODECA o programa de selección QuickFan.

Características acústicas

Espectro de potencia sonora Lw(A) en dB(A) por banda de frecuencia en Hz
Valores tomados a la aspiración con caudal máximo

	63	125	250	500	1000	2000	4000	8000		63	125	250	500	1000	2000	4000	8000
40-2-1.5	47	63	75	83	88	86	82	75	56-4-1.5	51	63	72	78	78	78	72	64
40-4-1.5 (2V)	32	48	60	68	73	71	67	60	56-8-1.5 (2V)	35	47	56	62	62	62	56	48
40-4-0.75	37	53	63	70	71	68	67	68	56-4-2	52	64	73	79	79	79	73	65
40-6-0.75	28	44	54	61	62	59	58	59	56-6-0.75	45	55	65	69	70	68	61	53
40-12-0.75 (2V)	12	28	38	45	46	43	42	43	56-12-0.75 (2V)	29	39	49	53	54	52	45	37
45-2-2	47	60	74	86	87	86	82	74	63-4-1	48	64	76	82	84	81	74	66
45-4-2 (2V)	32	45	59	71	72	71	67	59	63-4-1.5	47	63	75	81	83	80	73	65
45-4-0.75	47	59	67	73	73	73	68	60	63-8-1.5 (2V)	31	47	59	65	67	64	57	49
45-6-0.75	37	49	57	63	63	63	58	50	63-4-2	54	66	75	81	81	81	75	67
45-12-0.75 (2V)	21	33	41	47	47	47	42	34	63-8-2 (2V)	39	51	60	66	66	66	60	52
50-4-0.75	49	61	69	75	75	75	70	62	63-4-3	56	68	77	83	83	83	77	69
50-6-0.75	41	53	61	67	67	67	62	54	63-8-3 (2V)	41	53	62	68	68	68	62	54
56-4-1	51	63	72	78	78	78	72	64	63-4-4	57	69	78	84	84	84	78	70

Características acústicas

Espectro de potencia sonora Lw(A) en dB(A) por banda de frecuencia en Hz
Valores tomados a la aspiración con caudal máximo

	63	125	250	500	1000	2000	4000	8000		63	125	250	500	1000	2000	4000	8000
63-8-4 (2V)	42	54	63	69	69	69	63	55	90-4-5.5	60	76	87	93	94	92	87	79
63-6-0.75	48	58	68	72	73	71	64	56	90-8-5.5 (2V)	45	61	72	78	79	77	72	64
63-12-0.75 (2V)	32	42	52	56	57	55	48	40	90-4-7.5	59	75	86	92	93	91	86	78
63-6-1	49	59	69	73	74	72	65	57	90-8-7.5 (2V)	44	60	71	77	78	76	71	63
63-12-1 (2V)	32	42	52	56	57	55	48	40	90-4-10	58	74	85	91	92	90	85	77
71-4-1.5	57	73	80	86	86	86	82	74	90-8-10 (2V)	43	59	70	76	77	75	70	62
71-8-1.5 (2V)	41	57	64	70	70	70	66	58	90-6-2	52	67	78	82	82	78	71	63
71-4-2	56	72	79	85	85	85	81	73	90-12-2 (2V)	36	51	62	66	66	62	55	47
71-8-2 (2V)	41	57	64	70	70	70	66	58	90-6-3	52	67	78	82	82	78	71	63
71-4-3	56	72	79	85	85	85	81	73	90-12-3 (2V)	37	52	63	67	67	63	56	48
71-8-3 (2V)	41	57	64	70	70	70	66	58	90-6-4	60	70	80	85	85	82	76	68
71-4-4	63	75	79	85	85	86	83	75	90-12-4 (2V)	45	55	65	70	70	67	61	53
71-8-4 (2V)	48	60	64	70	70	71	68	60	90-8-1	42	63	70	75	78	74	67	56
71-6-0.75	46	53	73	76	76	71	63	55	90-8-2	51	66	73	78	81	77	70	59
71-12-0.75 (2V)	30	37	57	60	60	55	47	39	90-8-3	53	67	74	79	82	78	71	60
71-6-1	46	64	73	76	76	71	64	55	100-4-7.5	67	83	90	97	98	96	92	84
71-12-1 (2V)	29	47	56	59	59	54	47	38	100-8-7.5 (2V)	52	68	75	82	83	81	77	69
71-6-1.5	47	65	74	77	77	72	65	56	100-4-10	65	81	88	95	96	94	90	82
71-12-1.5 (2V)	32	50	59	62	62	57	50	41	100-8-10 (2V)	50	66	73	80	81	79	75	67
80-4-3	55	71	84	91	91	88	82	74	100-4-15	71	83	87	93	94	94	91	83
80-8-3 (2V)	40	56	69	76	76	73	67	59	100-8-15 (2V)	56	68	72	78	79	79	76	68
80-4-4	54	70	83	90	90	87	81	73	100-4-20	72	84	88	94	95	95	92	84
80-8-4 (2V)	39	55	68	75	75	72	66	58	100-8-20 (2V)	57	69	73	79	80	80	77	69
80-4-5.5	53	69	82	89	89	86	80	72	100-4-9-15	65	81	88	95	96	94	90	82
80-8-5.5 (2V)	38	54	67	74	74	71	65	57	100-4-9-20	72	84	88	94	95	95	92	84
80-6-1.5	53	68	75	78	79	76	70	62	100-4-9-25	72	84	88	94	95	95	92	84
80-12-1.5 (2V)	38	53	60	63	64	61	55	47	100-4-9-30	74	86	90	96	97	97	94	86
80-6-2	59	69	75	79	80	78	73	65	100-6-3	57	72	82	85	86	83	75	67
80-12-2 (2V)	43	53	59	63	64	62	57	49	100-12-3 (2V)	42	57	67	70	71	68	60	52
80-6-3	60	70	76	80	81	79	74	66	100-6-4	56	71	81	84	85	82	74	66
80-12-3 (2V)	45	55	61	65	66	64	59	51	100-12-4 (2V)	41	56	66	69	70	67	59	51
80-8-0.75	46	59	67	72	74	71	64	53	100-6-5.5	57	72	82	85	86	83	75	67
80-8-1	47	60	68	73	75	72	65	54	100-6/9-5.5	57	72	82	85	86	83	75	67
90-4-4	61	77	88	94	95	93	88	80	100-6/9-7.5	57	72	82	85	86	83	75	67
90-8-4 (2V)	46	62	73	79	80	78	73	65	100-6/9-10	58	73	83	86	87	84	76	68

Dimensiones mm

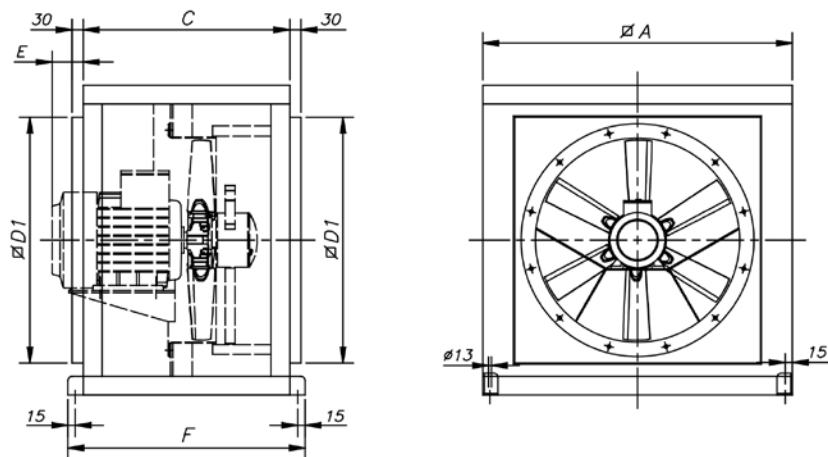

	A	C	øD1	E	F
CJTHT/PLUS-40/45/50	700	550	565	-	630
CJTHT/PLUS-56/63	825	550	690	140	630
CJTHT/PLUS-71/80	1000	650	850	-	730
CJTHT/PLUS-90/100	1200	750	1050	-	830

Curvas características

Ver curvas características serie: THT

Accesorios



Configuración con BOXPARK



Cuadros de control para sistemas de ventilación de aparcamientos con triple propósito: ventilación diaria, control de la concentración de CO y extracción de humo en caso de incendio

Cuadros de control en envoltorio metálica con todos los elementos necesarios para la gestión y control de los ventiladores de sistemas de ventilación de aparcamientos, ya estén basados en redes de conductos o en ventiladores de impulsos, para el control de los niveles de concentración de CO y la extracción de humo en caso de incendio. Cuadros a medida para todas las potencias y número de ventiladores según necesidades del proyecto.

Más información ver serie BOXPARK.

Ejemplos de instalación con BOXPARK

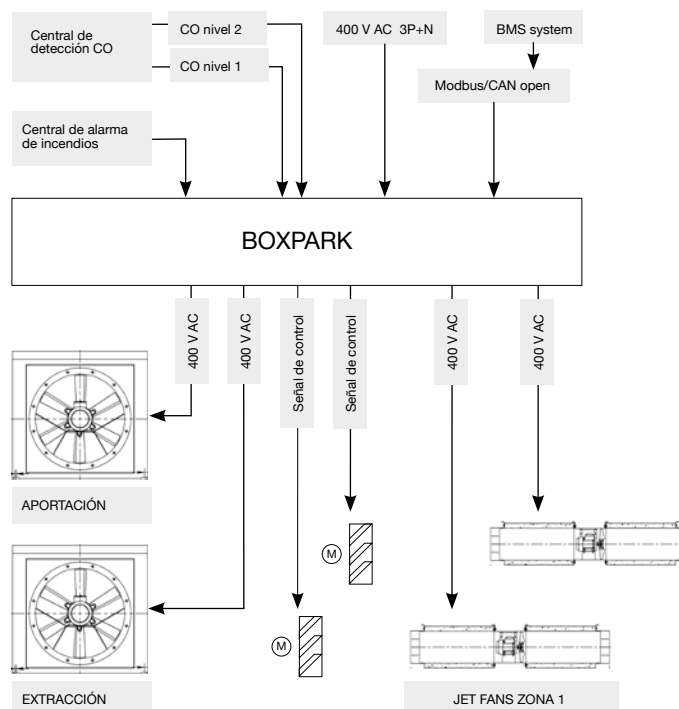

CJTHT

Ventiladores helicoidales 400 °C/2h y 300 °C/2h. Con caja aislada acústicamente



Unidades de extracción con ventiladores helicoidales para trabajar inmersas en zonas de riesgo de incendios.

Ventilador:

- Ventilador con envolvente tubular en chapa de acero.
- Estructura en chapa de acero galvanizado, con aislamiento térmico y acústico.
- Hélice de ángulo variable en fundición de aluminio.
- Homologación según norma EN 12101-3, con certificaciones n°: 0370-CPR-0312 (F400) y 0370-CPR-0974 (F300).

Motor:

- Motores clase H para uso continuo S1 y uso emergencia S2. Con rodamientos a bolas, protección IP55 y 1 o 2 velocidades según modelo.
- Motores con eficiencia IE3 para potencias iguales o superiores a 0,75 kW, excepto monofásicos, 2 velocidades y 8 polos.
- Trifásico 230/400 V 50 Hz (hasta 3 kW) y 400/690 V 50 Hz (potencias superiores a 3 kW).

- Temperatura máxima del aire a transportar: Servicio S1 -20 °C +40 °C en continuo, apto también para climas cálidos con temperaturas hasta 50 °C. Servicio S2 300 °C/2h, 400 °C/2h.

Acabado:

- Ventilador: Anticorrosivo en resina de poliéster polimerizada a 190 °C, previo desengrase con tratamiento nanotecnológico libre de fosfatos.
- Caja: anticorrosivo en chapa de acero galvanizado.

Versiones disponibles:

- CJTHT: Ventiladores helicoidales con caja aislada acústicamente.
- CJTHT/ATEX: Ventiladores helicoidales con caja aislada acústicamente, con certificación ATEX, categoría 3 Ex II3G para zona 2 (sólo 400 °C/2h y 300 °C/2h).
- CJTHT/PLUS: Ventiladores helicoidales con atenuador acústico.

Bajo demanda:

- Dirección aire hélice-motor.
- Hélices reversibles 100%.

Código de pedido

De tamaño 40 a tamaño 100

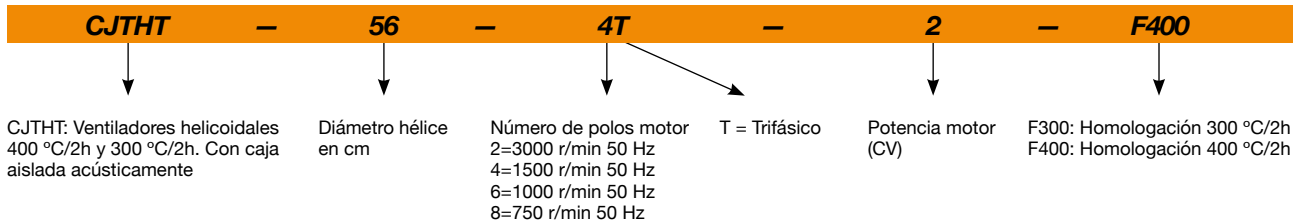

Tamaño 125

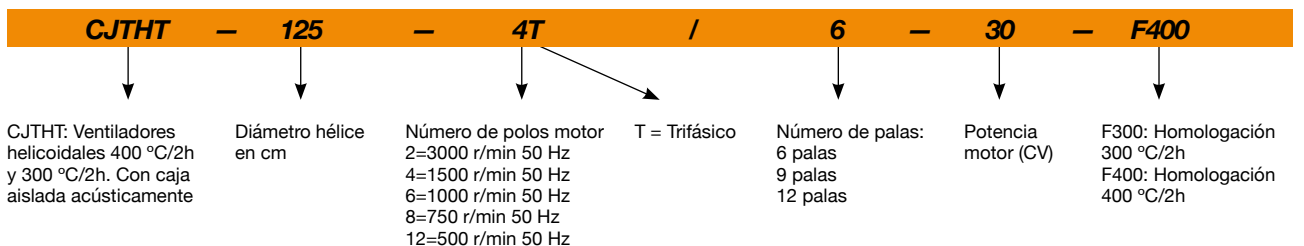

Características técnicas

Modelo	Velocidad (r/min)	Intensidad máxima admisible (A)			Potencia instalada (kW)	Ángulo inclinación palas (°)	Caudal máximo (m³/h)	Nivel presión sonora¹ dB (A) Aspiración	Peso aprox. (Kg)
		230V	400V	690V					
CJTHT-40-2/4T-1.5	2900 / 1435		2,89 / 1,04		1,10 / 0,25	20	7040 / 3480	71 / 56	50
CJTHT-40-4T-0.75	1420	2,84	1,64		0,55	32	4800	55	41
CJTHT-40-6T-0.75	930	2,90	1,75		0,55	32	3150	46	49
CJTHT-40-6/12T-0.75	940 / 455		2,35 / 1,15		0,60 / 0,15	32	3150 / 1520	46 / 31	53
CJTHT-45-2/4T-2	2940 / 1465		3,58 / 1,19		1,50 / 0,37	16	9400 / 4680	71 / 56	53
CJTHT-45-4T-0.75	1420	2,84	1,64		0,55	36	7450	58	43
CJTHT-45-6T-0.75	930	2,90	1,75		0,55	30	4450	48	51
CJTHT-45-6/12T-0.75	940 / 455		2,35 / 1,15		0,60 / 0,15	30	4450 / 2150	48 / 33	55
CJTHT-50-4T-0.75	1420	2,84	1,64		0,55	22	8390	60	48
CJTHT-50-6T-0.75	930	2,90	1,75		0,55	32	7000	52	52
CJTHT-56-4T-1 IE3	1430	3,08	1,79		0,75	22	11250	63	59
CJTHT-56-4T-1.5 IE3	1420	4,10	2,37		1,10	30	13600	63	61
CJTHT-56-4/8T-1.5	1440 / 705		2,69 / 1,12		1,10 / 0,25	30	13600 / 6640	63 / 48	65
CJTHT-56-4T-2 IE3	1425	5,89	3,38		1,50	36	15030	64	63
CJTHT-56-6T-0.75	930	2,90	1,75		0,55	38	10140	54	61
CJTHT-56-6/12T-0.75	940 / 455		2,35 / 1,15		0,60 / 0,15	38	10140 / 4890	54 / 39	65
CJTHT-63-4T-1 IE3	1430	3,08	1,79		0,75	14	15190	67	63
CJTHT-63-4T-1.5 IE3	1420	4,10	2,37		1,10	20	17800	66	66
CJTHT-63-4/8T-1.5	1440 / 705		2,69 / 1,12		1,10 / 0,25	20	17800 / 8680	66 / 51	69
CJTHT-63-4T-2 IE3	1425	5,89	3,38		1,50	24	19280	66	67
CJTHT-63-4/8T-2	1415 / 715		3,40 / 1,65		1,50 / 0,30	24	19280 / 9740	66 / 52	74
CJTHT-63-4T-3 IE3	1435	7,86	4,52		2,20	32	22150	68	73
CJTHT-63-4/8T-3	1415 / 700		4,80 / 1,85		2,20 / 0,45	32	22150 / 10920	68 / 53	87
CJTHT-63-4T-4 IE3	1430	11,01	6,33		3,00	38	24240	69	78
CJTHT-63-4/8T-4	1420 / 710		6,45 / 2,28		3,00 / 0,60	38	24240 / 12070	69 / 54	91
CJTHT-63-6T-0.75	930	2,90	1,75		0,55	28	13590	57	66
CJTHT-63-6/12T-0.75	940 / 455		2,35 / 1,15		0,60 / 0,15	28	13590 / 6550	57 / 42	69
CJTHT-63-6T-1 IE3	940	3,36	1,93		0,75	38	15890	58	67
CJTHT-63-6/12T-1	935 / 455		3,75 / 2,76		0,80 / 0,20	38	15890 / 7700	58 / 43	71
CJTHT-71-4T-1.5 IE3	1420	4,10	2,37		1,10	12	19480	71	82
CJTHT-71-4/8T-1.5	1440 / 705		2,69 / 1,12		1,10 / 0,25	12	19480 / 9500	71 / 56	86
CJTHT-71-4T-2 IE3	1425	5,89	3,38		1,50	14	20900	70	84
CJTHT-71-4/8T-2	1415 / 715		3,40 / 1,65		1,50 / 0,30	14	20900 / 10560	70 / 56	91
CJTHT-71-4T-3 IE3	1435	7,86	4,52		2,20	22	25100	70	90
CJTHT-71-4/8T-3	1415 / 700		4,80 / 1,85		2,20 / 0,45	22	25100 / 12370	70 / 55	103
CJTHT-71-4T-4 IE3	1430	11,01	6,33		3,00	28	27480	70	95
CJTHT-71-4/8T-4	1420 / 710		6,45 / 2,28		3,00 / 0,60	28	27480 / 13680	70 / 55	108
CJTHT-71-6T-0.75	930	2,90	1,75		0,55	20	16100	60	82
CJTHT-71-6/12T-0.75	940 / 455		2,35 / 1,15		0,60 / 0,15	20	16100 / 7760	60 / 45	86
CJTHT-71-6T-1 IE3	940	3,36	1,93		0,75	26	17300	60	84
CJTHT-71-6/12T-1	935 / 455		3,75 / 2,76		0,80 / 0,20	26	17300 / 8380	60 / 45	87
CJTHT-71-6T-1.5 IE3	945	4,73	2,72		1,10	34	19930	61	86
CJTHT-71-6/12T-1.5	940 / 460		3,52 / 2,00		1,20 / 0,30	34	19930 / 9760	61 / 46	97
CJTHT-80-4T-3 IE3	1435	7,86	4,52		2,20	12	25450	75	98
CJTHT-80-4/8T-3	1415 / 700		4,80 / 1,85		2,20 / 0,45	12	25450 / 12550	75 / 60	111
CJTHT-80-4T-4 IE3	1430	11,01	6,33		3,00	16	30250	74	103
CJTHT-80-4/8T-4	1420 / 710		6,45 / 2,28		3,00 / 0,60	16	30250 / 15060	74 / 59	115
CJTHT-80-4T-5.5 IE3	1440		7,95	4,61	4,00	18	32750	73	113
CJTHT-80-4/8T-5.5	1450 / 715		7,88 / 2,87		3,80 / 1,00	18	32750 / 16150	73 / 58	147
CJTHT-80-6T-1.5 IE3	945	4,73	2,72		1,10	18	21450	63	95
CJTHT-80-6/12T-1.5	940 / 460		3,52 / 2,00		1,20 / 0,30	18	21450 / 10500	63 / 48	105
CJTHT-80-6T-2 IE3	945	6,25	3,62		1,50	26	25950	64	99
CJTHT-80-6/12T-2	960 / 470		4,46 / 3,43		1,60 / 0,40	26	25950 / 12700	64 / 49	113
CJTHT-80-6T-3 IE3	950	9,78	5,62		2,20	32	29930	65	113

Características técnicas

Modelo	Velocidad (r/min)	Intensidad máxima admisible (A)			Potencia instalada (kW)	Ángulo inclinación palas (°)	Caudal máximo (m³/h)	Nivel presión sonora¹ dB (A) Aspiración	Peso aprox. (Kg)
		230V	400V	690V					
CJTHT-80-6/12T-3	940 / 475		5,62 / 3,32		2,20 / 0,55	32	29930 / 15120	65 / 51	118
CJTHT-80-8T-0.75	700	3,48	2,00		0,55	20	17540	57	99
CJTHT-80-8T-1	710	5,06	2,92		0,75	28	20650	58	111
CJTHT-90-4T-4 IE3	1430	11,01	6,33		3,00	8	33580	79	127
CJTHT-90-4/8T-4	1420 / 710		6,45 / 2,28		3,00 / 0,60	8	33580 / 16720	79 / 64	139
CJTHT-90-4T-5.5 IE3	1440		7,95	4,61	4,00	12	38890	78	137
CJTHT-90-4/8T-5.5	1450 / 715		7,88 / 2,87		3,80 / 1,00	12	38890 / 19170	78 / 63	171
CJTHT-90-4T-7.5 IE3	1430		10,40	6,04	5,50	18	46140	77	171
CJTHT-90-4/8T-7.5	1455 / 725		11,40 / 3,86		5,50 / 1,10	18	46140 / 22910	77 / 62	190
CJTHT-90-4T-10 IE3	1460		14,20	8,17	7,50	22	50140	76	208
CJTHT-90-4/8T-10	1455 / 725		15,10 / 5,16		7,50 / 1,50	22	50140 / 24900	76 / 61	198
CJTHT-90-6T-2 IE3	945	6,25	3,62		1,50	16	28780	66	123
CJTHT-90-6/12T-2	960 / 470		4,46 / 3,43		1,60 / 0,40	16	28780 / 14090	66 / 51	137
CJTHT-90-6T-3 IE3	950	9,78	5,62		2,20	24	34000	66	137
CJTHT-90-6/12T-3	940 / 475		5,62 / 3,32		2,20 / 0,55	24	34000 / 17180	66 / 52	142
CJTHT-90-6T-4 IE3	945	12,80	6,36		3,00	30	38900	69	171
CJTHT-90-6/12T-4	970 / 485		7,37 / 3,53		2,80 / 0,70	30	38900 / 19450	69 / 54	171
CJTHT-90-8T-1	710	5,06	2,92		0,75	18	22900	60	135
CJTHT-90-8T-2	700	7,32	4,21		1,50	30	29490	63	139
CJTHT-90-8T-3	705	9,30	5,35		2,20	32	30850	64	171
CJTHT-100-4T-7.5 IE3	1430		10,40	6,04	5,50	10	46850	82	179
CJTHT-100-4/8T-7.5	1455 / 725		11,40 / 3,86		5,50 / 1,10	10	46850 / 23260	82 / 67	198
CJTHT-100-4T-10 IE3	1460		14,20	8,17	7,50	16	57400	79	216
CJTHT-100-4/8T-10	1455 / 725		15,10 / 5,16		7,50 / 1,50	14	54710 / 27170	80 / 65	206
CJTHT-100-4T-15 IE3	1455		20,70	11,99	11,00	22	66300	79	251
CJTHT-100-4/8T-15	1470 / 730		20,70 / 7,19		11,00 / 3,00	22	66300 / 32880	79 / 64	251
CJTHT-100-4T-20 IE3	1460		27,80	16,03	15,00	28	76150	80	258
CJTHT-100-4/8T-20	1470 / 725		31,72 / 11,75		15,00 / 3,80	28	76150 / 37560	80 / 65	258
CJTHT-100-4T/9-15 IE3	1460		20,70	11,99	11,00	18	55340	80	260
CJTHT-100-4T/9-20 IE3	1460		27,80	16,03	15,00	22	63260	80	268
CJTHT-100-4T/9-25 IE3	1475		35,40	20,39	18,50	26	70620	80	308
CJTHT-100-4T/9-30 IE3	1475		42,20	24,44	22,00	30	74840	82	316
CJTHT-100-6T-3 IE3	950	9,78	5,62		2,20	16	37600	70	145
CJTHT-100-6/12T-3	940 / 475		5,62 / 3,32		2,20 / 0,55	16	37600 / 18990	70 / 56	150
CJTHT-100-6T-4 IE3	945	12,80	6,36		3,00	20	41150	69	179
CJTHT-100-6/12T-4	970 / 485		7,37 / 3,53		2,80 / 0,70	20	41150 / 20580	69 / 54	179
CJTHT-100-6T-5.5 IE3	970		8,37	4,82	4,00	26	47780	70	187
CJTHT-100-6T/9-5.5 IE3	970		11,00	6,35	4,00	20	39020	70	196
CJTHT-100-6T/9-7.5 IE3	970		12,30	7,07	5,50	26	46770	71	200
CJTHT-100-6T/9-10 IE3	970		15,20	8,83	7,50	34	52260	74	225
CJTHT-125-4T/6-20 IE3	1460		27,80	16,03	15,00	10	78600	87	466
CJTHT-125-4/8T/6-20	1470 / 725		31,72 / 11,75		15,00 / 3,80	10	78600 / 38770	87 / 72	485
CJTHT-125-4T/6-25 IE3	1465		35,40	20,39	18,50	14	92550	86	549
CJTHT-125-4/8T/6-27	1470 / 730		39,70 / 14,10		20,00 / 5,00	16	98830 / 48910	85 / 70	557
CJTHT-125-4T/6-30 IE3	1470		42,20	24,44	22,00	16	98830	85	554
CJTHT-125-4/8T/6-37	1475 / 735		54,55 / 18,50		28,00 / 6,50	20	110890 / 55260	85 / 70	633
CJTHT-125-4T/6-40 IE3	1475		53,30	31,02	30,00	22	117450	85	606
CJTHT-125-4T/6-50 IE3	1480		66,80	38,70	37,00	26	131050	85	734
CJTHT-125-4T/6-60 IE3	1475		80,90	46,90	45,00	28	135820	85	767
CJTHT-125-4T/6-75 IE3	1480		98,60	57,20	55,00	34	152100	88	848
CJTHT-125-4T/9-25 IE3	1465		35,40	20,39	18,50	10	79650	87	558
CJTHT-125-4T/9-30 IE3	1470		42,20	24,44	22,00	12	88290	86	563
CJTHT-125-4/8T/9-27	1470 / 730		39,70 / 14,10		20,00 / 5,00	12	88290 / 43690	86 / 71	566
CJTHT-125-4/8T/9-37	1475 / 735		54,55 / 18,50		28,00 / 6,50	16	104040 / 51840	85 / 70	642

Características técnicas

Modelo	Velocidad (r/min)	Intensidad máxima admisible (A)			Potencia instalada (kW)	Ángulo inclinación palas (°)	Caudal máximo (m³/h)	Nivel presión sonora¹ dB (A) Aspiración	Peso aprox. (Kg)
		230V	400V	690V					
CJTHT-125-4T/9-40 IE3	1475		53,30	31,02	30,00	16	104040	85	615
CJTHT-125-4T/9-50 IE3	1480		66,80	38,70	37,00	20	118400	85	743
CJTHT-125-4T/9-60 IE3	1475		80,90	46,90	45,00	24	134970	85	776
CJTHT-125-4T/9-75 IE3	1480		98,60	57,20	55,00	28	146770	86	857
CJTHT-125-4T/9-100 IE3	1480		128,00	74,22	75,00	34	158560	88	1018
CJTHT-125-4T/12-50 IE3	1480		66,80	38,70	37,00	18	101660	86	772
CJTHT-125-4T/12-60 IE3	1475		80,90	46,90	45,00	20	109180	86	785
CJTHT-125-4T/12-75 IE3	1480		98,60	57,20	55,00	26	131240	86	866
CJTHT-125-4T/12-100 IE3	1480		128,00	74,22	75,00	32	154100	88	1036
CJTHT-125-6T/6-5.5 IE3	970		8,37	4,82	4,00	10	51500	77	402
CJTHT-125-6T/6-7.5 IE3	970		12,30	7,07	5,50	14	60640	75	410
CJTHT-125-6/12T/6-7.5	970 / 480		14,50 / 5,17		5,50 / 1,00	14	60640 / 30010	75 / 60	454
CJTHT-125-6T/6-10 IE3	960		15,20	8,83	7,50	20	72650	74	458
CJTHT-125-6/12T/6-10	970 / 490		13,60 / 5,69		7,20 / 1,80	20	72650 / 36510	74 / 60	466
CJTHT-125-6T/6-15 IE3	955		22,50	13,07	11,00	26	85850	74	475
CJTHT-125-6/12T/6-15	970 / 485		23,10 / 8,41		11,00 / 3,00	26	85850 / 42710	74 / 59	566
CJTHT-125-6T/6-20 IE3	950		29,00	16,78	15,00	30	92850	76	542
CJTHT-125-6/12T/6-24	970 / 480		41,60 / 13,21		17,60 / 2,85	34	99650 / 49320	78 / 63	631
CJTHT-125-6T/9-10 IE3	960		15,20	8,83	7,50	14	63490	77	467
CJTHT-125-6/12T/9-10	970 / 490		13,60 / 5,69		7,20 / 1,80	14	63490 / 31910	77 / 63	475
CJTHT-125-6T/9-15 IE3	955		22,50	13,07	11,00	20	77550	75	484
CJTHT-125-6/12T/9-15	970 / 485		23,10 / 8,41		11,00 / 3,00	20	77550 / 38580	75 / 60	575
CJTHT-125-6T/9-20 IE3	950		29,00	16,78	15,00	26	92950	75	551
CJTHT-125-6/12T/9-24	970 / 480		41,60 / 13,21		17,60 / 2,85	30	98500 / 48750	76 / 61	640
CJTHT-125-6T/9-25 IE3	975		36,10	20,77	18,50	32	101450	77	627
CJTHT-125-6T/9-30 IE3	975		42,30	24,35	22,00	36	106520	80	638
CJTHT-125-6T/12-10 IE3	970		15,20	8,83	7,50	12	49630	79	496
CJTHT-125-6T/12-15 IE3	970		22,50	13,07	11,00	18	67310	77	513
CJTHT-125-6T/12-20 IE3	970		29,00	16,78	15,00	24	81840	76	580
CJTHT-125-6T/12-25 IE3	975		36,10	20,77	18,50	30	96770	77	656
CJTHT-125-6T/12-30 IE3	975		42,30	24,35	22,00	32	102040	78	667
CJTHT-125-6T/12-40 IE3	985		56,00	32,50	30,00	34	106350	79	782

1 Los valores de los niveles sonoros, son presiones en dB(A) medidos a 3 metros, en campo libre.



Erp. (Energy Related Products)

Información de la Directiva 2009/125/EC descargable desde la web de SODECA o programa de selección QuickFan.

Características acústicas

Espectro de potencia sonora Lw(A) en dB(A) por banda de frecuencia en Hz
Valores tomados a la aspiración con caudal máximo

	63	125	250	500	1000	2000	4000	8000		63	125	250	500	1000	2000	4000	8000
40-2-1.5	47	63	75	83	88	86	82	75	50-4-0.75	49	61	69	75	75	75	70	62
40-4-1.5 (2V)	32	48	60	68	73	71	67	60	50-6-0.75	41	53	61	67	67	67	62	54
40-4-0.75	37	53	63	70	71	68	67	68	56-4-1	51	63	72	78	78	78	72	64
40-6-0.75	28	44	54	61	62	59	58	59	56-4-1.5	51	63	72	78	78	78	72	64
40-12-0.75 (2V)	12	28	38	45	46	43	42	43	56-8-1.5 (2V)	35	47	56	62	62	62	56	48
45-2-2	47	60	74	86	87	86	82	74	56-4-2	52	64	73	79	79	79	73	65
45-4-2 (2V)	32	45	59	71	72	71	67	59	56-6-0.75	45	55	65	69	70	68	61	53
45-4-0.75	47	59	67	73	73	73	68	60	56-12-0.75 (2V)	29	39	49	53	54	52	45	37
45-6-0.75	37	49	57	63	63	63	58	50	63-4-1	48	64	76	82	84	81	74	66
45-12-0.75 (2V)	21	33	41	47	47	47	42	34	63-4-1.5	47	63	75	81	83	80	73	65

Características acústicas

Espectro de potencia sonora Lw(A) en dB(A) por banda de frecuencia en Hz
Valores tomados a la aspiración con caudal máximo

	63	125	250	500	1000	2000	4000	8000		63	125	250	500	1000	2000	4000	8000
63-8-1.5 (2V)	31	47	59	65	67	64	57	49	100-4/9-15	65	81	88	95	96	94	90	82
63-4-2	54	66	75	81	81	81	75	67	100-4/9-20	72	84	88	94	95	95	92	84
63-8-2 (2V)	39	51	60	66	66	66	60	52	100-4/9-25	72	84	88	94	95	95	92	84
63-4-3	56	68	77	83	83	83	77	69	100-4/9-30	74	86	90	96	97	97	94	86
63-8-3 (2V)	41	53	62	68	68	68	62	54	100-6-3	57	72	82	85	86	83	75	67
63-4-4	57	69	78	84	84	84	78	70	100-12-3 (2V)	42	57	67	70	71	68	60	52
63-8-4 (2V)	42	54	63	69	69	69	63	55	100-6-4	56	71	81	84	85	82	74	66
63-6-0.75	48	58	68	72	73	71	64	56	100-12-4 (2V)	41	56	66	69	70	67	59	51
63-12-0.75 (2V)	32	42	52	56	57	55	48	40	100-6-5.5	57	72	82	85	86	83	75	67
63-6-1	49	59	69	73	74	72	65	57	100-6/9-5.5	57	72	82	85	86	83	75	67
63-12-1 (2V)	32	42	52	56	57	55	48	40	100-6/9-7.5	58	73	83	86	87	84	76	68
71-4-1.5	57	73	80	86	86	86	82	74	100-6/9-10	61	76	86	89	90	87	79	71
71-8-1.5 (2V)	41	57	64	70	70	70	66	58	125-4/6-20	69	85	96	103	104	102	95	87
71-4-2	56	72	79	85	85	85	81	73	125-8/6-20 (2V)	54	70	81	88	89	87	80	72
71-8-2 (2V)	41	57	64	70	70	70	66	58	125-4/6-25	68	84	95	102	103	101	94	86
71-4-3	56	72	79	85	85	85	81	73	125-4/6-27	67	83	94	101	102	100	93	85
71-8-3 (2V)	41	57	64	70	70	70	66	58	125-8/6-27 (2V)	52	68	79	86	87	85	78	70
71-4-4	63	75	79	85	85	86	83	75	125-4/6-30	67	83	94	101	102	100	93	85
71-8-4 (2V)	48	60	64	70	70	71	68	60	125-4/6-37	67	83	94	101	102	100	93	85
71-6-0.75	46	53	73	76	76	71	63	55	125-8/6-37 (2V)	52	68	79	86	87	85	78	70
71-12-0.75 (2V)	30	37	57	60	60	55	47	39	125-4/6-40	67	83	94	101	102	100	93	85
71-6-1	46	64	73	76	76	71	64	55	125-4/6-50	67	83	94	101	102	100	93	85
71-12-1 (2V)	29	47	56	59	59	54	47	38	125-4/6-60	67	83	94	101	102	100	93	85
71-6-1.5	47	65	74	77	77	72	65	56	125-4/6-75	70	86	97	104	105	103	96	88
71-12-1.5 (2V)	32	50	59	62	62	57	50	41	125-4/9-25	67	81	94	102	104	101	96	88
80-4-3	55	71	84	91	91	88	82	74	125-4/9-27	66	80	93	101	103	100	95	87
80-8-3 (2V)	40	56	69	76	76	73	67	59	125-8/9-27 (2V)	51	65	78	86	88	85	80	72
80-4-4	54	70	83	90	90	87	81	73	125-4/9-30	66	80	93	101	103	100	95	87
80-8-4 (2V)	39	55	68	75	75	72	66	58	125-4/9-37	65	79	92	100	102	99	94	86
80-4-5.5	53	69	82	89	89	86	80	72	125-8/9-37 (2V)	50	64	77	85	87	84	79	71
80-8-5.5 (2V)	38	54	67	74	74	71	65	57	125-4/9-40	65	79	92	100	102	99	94	86
80-6-1.5	53	68	75	78	79	76	70	62	125-4/9-50	65	79	92	100	102	99	94	86
80-12-1.5 (2V)	38	53	60	63	64	61	55	47	125-4/9-60	73	86	95	99	101	100	96	89
80-6-2	59	69	75	79	80	78	73	65	125-4/9-75	74	87	96	100	102	101	97	90
80-12-2 (2V)	43	53	59	63	64	62	57	49	125-4/9-100	76	89	98	102	104	103	99	92
80-6-3	60	70	76	80	81	79	74	66	125-4/12-50	66	80	93	101	103	100	95	87
80-12-3 (2V)	45	55	61	65	66	64	59	51	125-4/12-60	66	80	93	101	103	100	95	87
80-8-0.75	46	59	67	72	74	71	64	53	125-4/12-75	74	87	96	100	102	101	97	90
80-8-1	47	60	68	73	75	72	65	54	125-4/12-100	76	89	98	102	104	103	99	92
90-4-4	61	77	88	94	95	93	88	80	125-6/6-5.5	64	79	89	92	93	90	85	77
90-8-4 (2V)	46	62	73	79	80	78	73	65	125-6/6-7.5	62	77	87	90	91	88	83	75
90-4-5.5	60	76	87	93	94	92	87	79	125-12/6-7.5 (2V)	47	62	72	75	76	73	68	60
90-8-5.5 (2V)	45	61	72	78	79	77	72	64	125-6/6-10	61	76	86	89	90	87	82	74
90-4-7.5	59	75	86	92	93	91	86	78	125-12/6-10 (2V)	46	61	71	74	75	72	67	59
90-8-7.5 (2V)	44	60	71	77	78	76	71	63	125-6/6-15	61	76	86	89	90	87	82	74
90-4-10	58	74	85	91	92	90	85	77	125-12/6-15 (2V)	45	60	70	73	74	71	66	58
90-8-10 (2V)	43	59	70	76	77	75	70	62	125-6/6-20	63	78	88	91	92	89	84	76
90-6-2	52	67	78	82	82	78	71	63	125-6/6-24	65	80	90	93	94	91	86	78
90-12-2 (2V)	36	51	62	66	66	62	55	47	125-12/6-24 (2V)	50	65	75	78	79	76	71	63
90-6-3	52	67	78	82	82	78	71	63	125-6/9-10	61	76	87	93	94	88	84	77
90-12-3 (2V)	37	52	63	67	67	63	56	48	125-12/9-10 (2V)	46	61	72	78	79	73	69	62
90-6-4	60	70	80	85	85	82	76	68	125-6/9-15	59	74	85	91	92	86	82	75
90-12-4 (2V)	45	55	65	70	70	67	61	53	125-12/9-15 (2V)	43	58	69	75	76	70	66	59
90-8-1	42	63	70	75	78	74	67	56	125-6/9-20	59	74	85	91	92	86	82	75
90-8-2	51	66	73	78	81	77	70	59	125-6/9-24	60	75	86	92	93	87	83	76
90-8-3	53	67	74	79	82	78	71	60	125-12/9-24 (2V)	45	60	71	77	78	72	68	61
100-4-7.5	67	83	90	97	98	96	92	84	125-6/9-25	61	76	87	93	94	88	84	77
100-8-7.5 (2V)	52	68	75	82	83	81	77	69	125-6/9-30	64	79	90	96	97	91	87	80
100-4-10	65	81	88	95	96	94	90	82	125-6/12-10	63	78	89	95	96	90	86	79
100-8-10 (2V)	50	66	73	80	81	79	75	67	125-6/12-15	61	76	87	93	94	88	84	77
100-4-15	71	83	87	93	94	94	91	83	125-6/12-20	60	75	86	92	93	87	83	76
100-8-15 (2V)	56	68	72	78	79	79	76	68	125-6/12-25	61	76	87	93	94	88	84	77
100-4-20	72	84	88	94	95	95	92	84	125-6/12-30	62	77	88	94	95	89	85	78
100-8-20 (2V)	57	69	73	79	80	80	77	69	125-6/12-40	63	78	89	95	96	90	86	79

Dimensiones mm

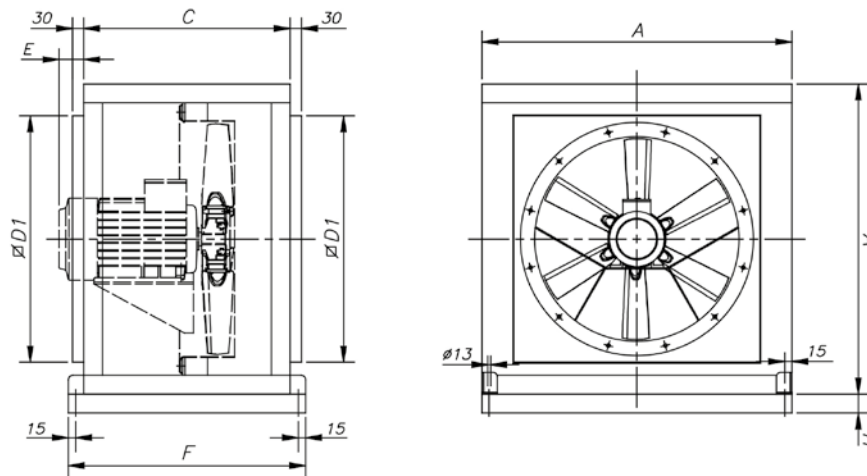

	A	C	ØD1	E	F	H
CJTHT-40/45/50	700	550	565	-	630	-
CJTHT-56/63	825	550	690	140	630	-
CJTHT-71/80	1000	650	850	-	730	-
CJTHT-90/100	1200	750	1050	-	830	-
CJTHT-125 ≤20 CV	1600	1200	1400	-	1280	-
CJTHT-125 >20 CV	1600	1200	1400	123	1280	100

Curvas características

Ver curvas características serie: THT

Accesorios



INT



IAT



CABLE BOX



C2V



VSD3/A-RFT
- VSD1/A-RFM



CENTRAL CO



AET



P-400



BOXPARK

Configuración con BOXPARK



Cuadros de control para sistemas de ventilación de aparcamientos con triple propósito: ventilación diaria, control de la concentración de CO y extracción de humo en caso de incendio

Cuadros de control en envoltorio metálica con todos los elementos necesarios para la gestión y control de los ventiladores de sistemas de ventilación de aparcamientos, ya estén basados en redes de conductos o en ventiladores de impulsos, para el control de los niveles de concentración de CO y la extracción de humo en caso de incendio. Cuadros a medida para todas las potencias y número de ventiladores según necesidades del proyecto.

Más información ver serie BOXPARK.

Ejemplos de instalación con BOXPARK

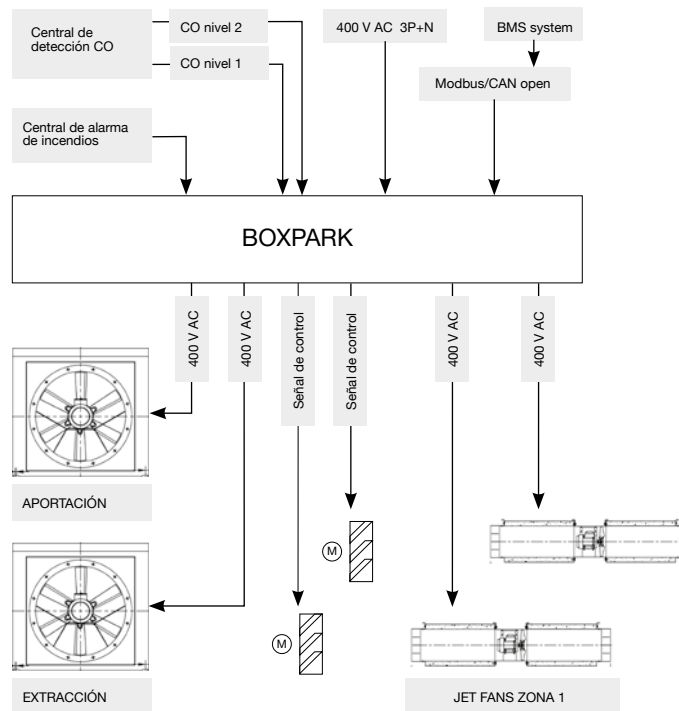

CJTHT/ATEX

Unidades de extracción helicoidales 400 °C/2h y 300 °C/2h, con certificación ATEX



Unidades de extracción con ventiladores helicoidales para trabajar inmersas en zonas de riesgo de incendios.

Ventilador:

- Ventilador con envolvente tubular en chapa de acero.
- Estructura en chapa de acero galvanizado, con aislamiento térmico y acústico.
- Hélice de ángulo variable en fundición de aluminio.
- Homologación según norma EN 12101-3, con certificaciones n°: 0370-CPR-0312 (F400) y 0370-CPR-0974 (F300).

Motor:

- Motores clase H para uso continuo S1 y uso emergencia S2. Con rodamientos a bolas, protección IP55 y 1 o 2 velocidades según modelo.
- Motores con eficiencia IE3 para potencias iguales o superiores a 0,75 kW, excepto monofásicos, 2 velocidades y 8 polos.
- Trifásico 230/400 V 50 Hz (hasta 3 kW) y 400/690 V 50 Hz (potencias superiores a 3 kW).

- Temperatura máxima del aire a transportar: Servicio S1 -20 °C +40 °C en continuo, apto también para climas cálidos con temperaturas hasta 50 °C. Servicio S2 300 °C/2h, 400 °C/2h.

Acabado:

- Ventilador: Anticorrosivo en resina de poliéster polimerizada a 190 °C, previo desengrase con tratamiento nanotecnológico libre de fosfatos.
- Caja: anticorrosivo en chapa de acero galvanizado.

Versiones disponibles:

- CJTHT: Ventiladores helicoidales con caja aislada acústicamente.
- CJTHT/ATEX: Ventiladores helicoidales con caja aislada acústicamente, con certificación ATEX, categoría 3 Ex II3G para zona 2 (sólo 400 °C/2h y 300 °C/2h).
- CJTHT/PLUS: Ventiladores helicoidales con atenuador acústico.

Bajo demanda:

- Dirección aire hélice-motor.
- Hélices reversibles 100%.

Código de pedido

De tamaño 40 a tamaño 100

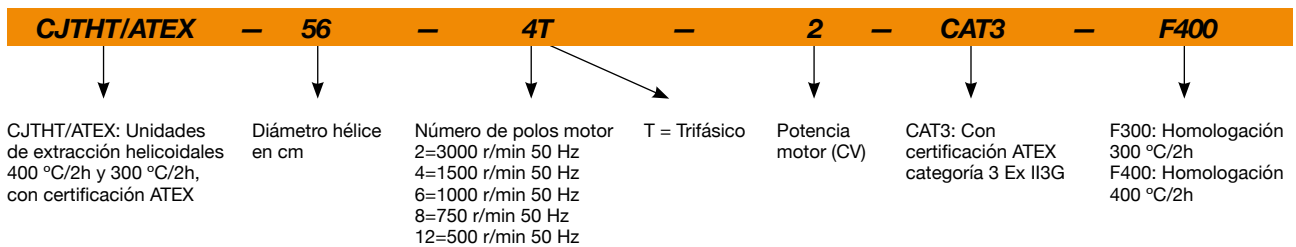

Tamaño 125

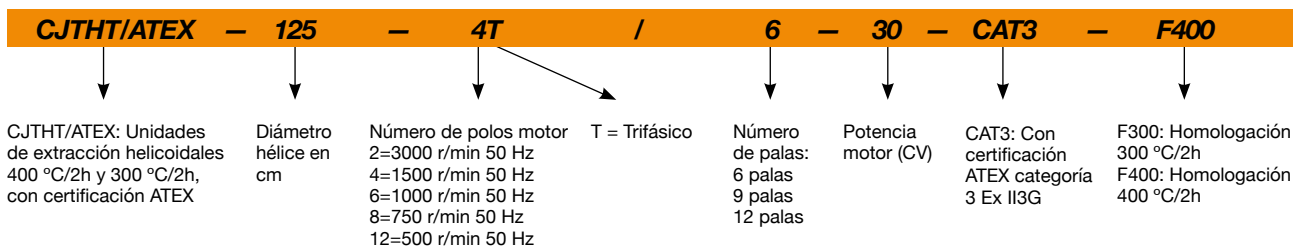

Características técnicas

Modelo	Velocidad (r/min)	Intensidad máxima admisible (A)			Potencia instalada (kW)	Ángulo inclinación palas (°)	Caudal máximo (m³/h)	Nivel presión sonora¹ dB (A) Aspiración	Peso aprox. (Kg)
		230V	400V	690V					
CJTHT/ATEX-40-2/4T-1.5/CAT3	2920 / 1445		2,89 / 1,04		1,10 / 0,25	20	7040 / 3480	71 / 56	50
CJTHT/ATEX-40-4T-0.75/CAT3	1420	2,84	1,64		0,55	32	4820	55	41
CJTHT/ATEX-40-6T-0.75/CAT3	930	2,90	1,75		0,55	32	3150	46	49
CJTHT/ATEX-40-6/12T-0.75/CAT3	940 / 455		2,35 / 1,15		0,60 / 0,15	32	3150 / 1520	46 / 31	53
CJTHT/ATEX-45-2/4T-2/CAT3	2940 / 1465		3,58 / 1,19		1,50 / 0,37	16	9400 / 4680	71 / 56	53
CJTHT/ATEX-45-4T-0.75/CAT3	1420	2,84	1,64		0,55	36	7470	58	43
CJTHT/ATEX-45-6T-0.75/CAT3	930	2,90	1,75		0,55	30	4460	48	51
CJTHT/ATEX-45-6/12T-0.75/CAT3	940 / 455		2,35 / 1,15		0,60 / 0,15	30	4460 / 2150	48 / 33	55
CJTHT/ATEX-50-4T-0.75/CAT3	1420	2,84	1,64		0,55	22	8390	60	48
CJTHT/ATEX-50-6T-0.75/CAT3	930	2,90	1,75		0,55	32	7030	52	52
CJTHT/ATEX-56-4T-1/CAT3	1420	3,08	1,79		0,75	22	11280	63	59
CJTHT/ATEX-56-4T-1.5/CAT3	1420	4,10	2,37		1,10	30	13550	63	61
CJTHT/ATEX-56-4/8T-1.5/CAT3	1440 / 705		2,69 / 1,12		1,10 / 0,25	30	13550 / 6610	63 / 48	65
CJTHT/ATEX-56-4T-2/CAT3	1425	5,89	3,38		1,50	36	15030	64	63
CJTHT/ATEX-56-6T-0.75/CAT3	930	2,90	1,75		0,55	38	10140	54	61
CJTHT/ATEX-56-6/12T-0.75/CAT3	940 / 455		2,35 / 1,15		0,60 / 0,15	38	10140 / 4890	54 / 39	65
CJTHT/ATEX-63-4T-1/CAT3	1420	3,08	1,79		0,75	14	15190	67	63
CJTHT/ATEX-63-4T-1.5/CAT3	1420	4,10	2,37		1,10	20	17800	66	66
CJTHT/ATEX-63-4/8T-1.5/CAT3	1440 / 705		2,69 / 1,12		1,10 / 0,25	20	17800 / 8680	66 / 51	69
CJTHT/ATEX-63-4T-2/CAT3	1425	5,89	3,38		1,50	24	19280	66	67
CJTHT/ATEX-63-4/8T-2/CAT3	1415 / 715		3,40 / 1,65		1,50 / 0,30	24	19280 / 9740	66 / 52	74
CJTHT/ATEX-63-4T-3/CAT3	1435	7,86	4,52		2,20	32	22170	68	73
CJTHT/ATEX-63-4/8T-3/CAT3	1415 / 700		4,80 / 1,85		2,20 / 0,45	32	22170 / 10930	68 / 53	87
CJTHT/ATEX-63-4T-4/CAT3	1430	11,01	6,33		3,00	38	24240	69	78
CJTHT/ATEX-63-4/8T-4/CAT3	1425 / 710		6,45 / 2,28		3,00 / 0,60	38	24240 / 12070	69 / 54	91
CJTHT/ATEX-63-6T-0.75/CAT3	930	2,90	1,75		0,55	28	13590	57	66
CJTHT/ATEX-63-6/12T-0.75/CAT3	940 / 455		2,35 / 1,15		0,60 / 0,15	28	13590 / 6550	57 / 42	69
CJTHT/ATEX-63-6T-1/CAT3	940	3,36	1,93		0,75	38	15890	58	67
CJTHT/ATEX-63-6/12T-1/CAT3	935 / 455		3,75 / 2,76		0,80 / 0,20	38	15890 / 7700	58 / 43	71
CJTHT/ATEX-71-4T-1.5/CAT3	1420	4,10	2,37		1,10	12	19480	71	82
CJTHT/ATEX-71-4/8T-1.5/CAT3	1440 / 705		2,69 / 1,12		1,10 / 0,25	12	19480 / 9500	71 / 56	86
CJTHT/ATEX-71-4T-2/CAT3	1425	5,89	3,38		1,50	14	20920	70	84
CJTHT/ATEX-71-4/8T-2/CAT3	1415 / 715		3,40 / 1,65		1,50 / 0,30	14	20920 / 10570	70 / 56	91
CJTHT/ATEX-71-4T-3/CAT3	1435	7,86	4,52		2,20	22	25110	70	90
CJTHT/ATEX-71-4/8T-3/CAT3	1415 / 700		4,80 / 1,85		2,20 / 0,45	22	25110 / 12380	70 / 55	103
CJTHT/ATEX-71-4T-4/CAT3	1430	11,01	6,33		3,00	28	27480	70	95
CJTHT/ATEX-71-4/8T-4/CAT3	1425 / 710		6,45 / 2,28		3,00 / 0,60	28	27480 / 13680	70 / 55	108
CJTHT/ATEX-71-6T-0.75/CAT3	930	2,90	1,75		0,55	20	16100	60	82
CJTHT/ATEX-71-6/12T-0.75/CAT3	940 / 455		2,35 / 1,15		0,60 / 0,15	20	16100 / 7760	60 / 45	86
CJTHT/ATEX-71-6T-1/CAT3	940	3,36	1,93		0,75	26	17310	60	84
CJTHT/ATEX-71-6/12T-1/CAT3	935 / 455		3,75 / 2,76		0,80 / 0,20	26	17310 / 8390	60 / 45	87
CJTHT/ATEX-71-6T-1.5/CAT3	945	4,73	2,72		1,10	34	19930	61	86
CJTHT/ATEX-71-6/12T-1.5/CAT3	940 / 460		3,52 / 2,00		1,20 / 0,30	34	19930 / 9760	61 / 46	97
CJTHT/ATEX-80-4T-3/CAT3	1435	7,86	4,52		2,20	12	25460	75	98
CJTHT/ATEX-80-4/8T-3/CAT3	1415 / 700		4,80 / 1,85		2,20 / 0,45	12	25460 / 12550	75 / 60	111
CJTHT/ATEX-80-4T-4/CAT3	1430	11,01	6,33		3,00	16	30270	74	103
CJTHT/ATEX-80-4/8T-4/CAT3	1425 / 710		6,45 / 2,28		3,00 / 0,60	16	30270 / 15070	74 / 59	115
CJTHT/ATEX-80-4T-5.5/CAT3	1440		7,95	4,61	4,00	18	32770	73	113
CJTHT/ATEX-80-4/8T-5.5/CAT3	1455 / 720		7,88 / 2,87		3,80 / 1,00	18	32770 / 16160	73 / 58	147
CJTHT/ATEX-80-6T-1.5/CAT3	945	4,73	2,72		1,10	18	21470	63	95
CJTHT/ATEX-80-6/12T-1.5/CAT3	940 / 460		3,52 / 2,00		1,20 / 0,30	18	21470 / 10510	63 / 48	105
CJTHT/ATEX-80-6T-2/CAT3	945	6,25	3,62		1,50	26	25970	64	99
CJTHT/ATEX-80-6/12T-2/CAT3	960 / 470		4,46 / 3,43		1,60 / 0,40	26	25970 / 12710	64 / 49	113
CJTHT/ATEX-80-6T-3/CAT3	950	9,78	5,62		2,20	32	29930	65	113

Características técnicas

Modelo	Velocidad (r/min)	Intensidad máxima admisible (A)			Potencia instalada (kW)	Ángulo inclinación palas (°)	Caudal máximo (m³/h)	Nivel presión sonora¹ dB (A) Aspiración	Peso aprox. (Kg)
		230V	400V	690V					
CJTHT/ATEX-80-6/12T-3/CAT3	940 / 475		5,62 / 3,32		2,20 / 0,55	32	29930 / 15120	65 / 51	118
CJTHT/ATEX-80-8T-0.75/CAT3	700	3,48	2,00		0,55	20	17540	57	99
CJTHT/ATEX-80-8T-1/CAT3	710	5,06	2,92		0,75	28	20680	58	111
CJTHT/ATEX-90-4T-4/CAT3	1430	11,01	6,33		3,00	8	33580	79	127
CJTHT/ATEX-90-4/8T-4/CAT3	1425 / 710		6,45 / 2,28		3,00 / 0,60	8	33580 / 16720	79 / 64	139
CJTHT/ATEX-90-4T-5.5/CAT3	1440		7,95	4,61	4,00	12	38890	78	137
CJTHT/ATEX-90-4/8T-5.5/CAT3	1455 / 720		7,88 / 2,87		3,80 / 1,00	12	38890 / 19170	78 / 63	171
CJTHT/ATEX-90-4T-7.5/CAT3	1460		10,40	6,04	5,50	18	46140	77	171
CJTHT/ATEX-90-4/8T-7.5/CAT3	1455 / 725		11,40 / 3,86		5,50 / 1,10	18	46140 / 22910	77 / 62	190
CJTHT/ATEX-90-4T-10/CAT3	1460		14,20	8,17	7,50	22	50140	76	208
CJTHT/ATEX-90-4/8T-10/CAT3	1455 / 725		15,10 / 5,16		7,50 / 1,50	22	50140 / 24900	76 / 61	198
CJTHT/ATEX-90-6T-2/CAT3	945	6,25	3,62		1,50	16	28780	66	123
CJTHT/ATEX-90-6/12T-2/CAT3	960 / 470		4,46 / 3,43		1,60 / 0,40	16	28780 / 14090	66 / 51	137
CJTHT/ATEX-90-6T-3/CAT3	950	9,78	5,62		2,20	24	34000	66	137
CJTHT/ATEX-90-6/12T-3/CAT3	940 / 475		5,62 / 3,32		2,20 / 0,55	24	34000 / 17180	66 / 52	142
CJTHT/ATEX-90-6T-4/CAT3	970	12,80	6,36		3,00	30	38910	69	171
CJTHT/ATEX-90-6/12T-4/CAT3	970 / 485		7,37 / 3,53		2,80 / 0,70	30	38910 / 19460	69 / 54	171
CJTHT/ATEX-90-8T-1/CAT3	710	5,06	2,92		0,75	18	22910	60	135
CJTHT/ATEX-90-8T-2/CAT3	700	7,32	4,21		1,50	30	29490	63	139
CJTHT/ATEX-90-8T-3/CAT3	710	9,30	5,35		2,20	32	30850	64	171
CJTHT/ATEX-100-4T-7.5/CAT3	1460		10,40	6,04	5,50	10	46870	82	179
CJTHT/ATEX-100-4/8T-7.5/CAT3	1455 / 725		11,40 / 3,86		5,50 / 1,10	10	46870 / 23270	82 / 67	198
CJTHT/ATEX-100-4T-10/CAT3	1460		14,20	8,17	7,50	16	57420	79	216
CJTHT/ATEX-100-4/8T-10/CAT3	1455 / 725		15,10 / 5,16		7,50 / 1,50	14	54710 / 27170	80 / 65	206
CJTHT/ATEX-100-4T-15/CAT3	1460		20,70	11,99	11,00	22	66300	79	251
CJTHT/ATEX-100-4/8T-15/CAT3	1470 / 730		20,70 / 7,19		11,00 / 3,00	22	66300 / 32880	79 / 64	251
CJTHT/ATEX-100-4T-20/CAT3	1460		27,80	16,03	15,00	28	76160	80	258
CJTHT/ATEX-100-4/8T-20/CAT3	1470 / 725		31,72 / 11,75		15,00 / 3,80	28	76160 / 37560	80 / 65	258
CJTHT/ATEX-100-4T/9-15/CAT3	1460		20,70	11,99	11,00	18	55345	80	260
CJTHT/ATEX-100-4T/9-20/CAT3	1460		27,80	16,03	15,00	22	63265	80	268
CJTHT/ATEX-100-4T/9-25/CAT3	1475		35,40	20,39	18,50	26	70625	80	308
CJTHT/ATEX-100-4T/9-30/CAT3	1475		42,20	24,44	22,00	30	74845	82	316
CJTHT/ATEX-100-6T-3/CAT3	950	9,78	5,62		2,20	16	37620	70	145
CJTHT/ATEX-100-6/12T-3/CAT3	940 / 475		5,62 / 3,32		2,20 / 0,55	16	37620 / 19000	70 / 56	150
CJTHT/ATEX-100-6T-4/CAT3	970	12,80	6,36		3,00	20	41180	69	179
CJTHT/ATEX-100-6/12T-4/CAT3	970 / 485		7,37 / 3,53		2,80 / 0,70	20	41180 / 20590	69 / 54	179
CJTHT/ATEX-100-6T-5.5/CAT3	970		8,37	4,82	4,00	26	47780	70	187
CJTHT/ATEX-100-6T/9-5.5/CAT3	970		11,00	6,35	4,00	20	39020	70	196
CJTHT/ATEX-100-6T/9-7.5/CAT3	970		12,30	7,07	5,50	26	46765	71	200
CJTHT/ATEX-100-6T/9-10/CAT3	970		15,20	8,83	7,50	34	52255	74	225
CJTHT/ATEX-125-4T/6-20/CAT3	1455		27,80	16,03	15,00	10	78610	87	466
CJTHT/ATEX-125-4/8T/6-20/CAT3	1455 / 720		31,72 / 11,75		15,00 / 3,80	10	78610 / 38770	87 / 72	485
CJTHT/ATEX-125-4T/6-25/CAT3	1470		35,40	20,39	18,50	14	92000	86	549
CJTHT/ATEX-125-4/8T/6-27/CAT3	1470 / 730		39,70 / 14,10		20,00 / 5,00	16	98100 / 48550	85 / 70	557
CJTHT/ATEX-125-4T/6-30/CAT3	1470		42,20	24,44	22,00	16	98830	85	554
CJTHT/ATEX-125-4/8T/6-37/CAT3	1480 / 740		54,55 / 18,50		28,00 / 6,50	20	110250 / 54940	85 / 70	633
CJTHT/ATEX-125-4T/6-40/CAT3	1475		55,19	31,87	30,00	22	117000	85	606
CJTHT/ATEX-125-4T/6-50/CAT3	1480		66,40	38,26	37,00	26	130450	85	734
CJTHT/ATEX-125-4T/6-60/CAT3	1475		80,90	46,90	45,00	28	135820	85	747
CJTHT/ATEX-125-4T/6-75/CAT3	1480		98,60	57,20	55,00	34	152100	88	828
CJTHT/ATEX-125-4T/9-25/CAT3	1470		35,40	20,39	18,50	10	79680	87	558
CJTHT/ATEX-125-4T/9-30/CAT3	1470		42,20	24,44	22,00	12	88290	86	563
CJTHT/ATEX-125-4/8T/9-27/CAT3	1470 / 730		39,70 / 14,10		20,00 / 5,00	12	88290 / 43690	86 / 71	566
CJTHT/ATEX-125-4/8T/9-37/CAT3	1480 / 740		54,55 / 18,50		28,00 / 6,50	16	104040 / 51840	85 / 70	642

Características técnicas

Modelo	Velocidad (r/min)	Intensidad máxima admisible (A)			Potencia instalada (kW)	Ángulo inclinación palas (°)	Caudal máximo (m³/h)	Nivel presión sonora¹ dB (A) Aspiración	Peso aprox. (Kg)
		230V	400V	690V					
CJTHT/ATEX-125-4T/9-40/CAT3	1475		55,19	31,87	30,00	16	104040	85	615
CJTHT/ATEX-125-4T/9-50/CAT3	1480		66,40	38,26	37,00	20	118350	85	743
CJTHT/ATEX-125-4T/9-60/CAT3	1475		80,90	46,90	45,00	24	134970	85	756
CJTHT/ATEX-125-4T/9-75/CAT3	1480		98,60	57,20	55,00	28	146770	86	837
CJTHT/ATEX-125-4T/9-100/CAT3	1480		128,00	74,22	75,00	34	158560	88	998
CJTHT/ATEX-125-4T/12-50/CAT3	1480		66,80	38,70	37,00	18	101660	86	752
CJTHT/ATEX-125-4T/12-60/CAT3	1475		80,90	46,90	45,00	20	109180	86	765
CJTHT/ATEX-125-4T/12-75/CAT3	1480		98,60	57,20	55,00	26	131240	86	846
CJTHT/ATEX-125-4T/12-100/CAT3	1480		128,00	74,22	75,00	32	154100	88	1016
CJTHT/ATEX-125-6T/6-5.5/CAT3	940		8,37	4,82	4,00	10	51300	77	402
CJTHT/ATEX-125-6T/6-7.5/CAT3	960		12,30	7,07	5,50	14	60640	75	410
CJTHT/ATEX-125-6/12T/6-7.5/CAT3	980 / 485		14,50 / 5,17		5,50 / 1,00	14	60640 / 30010	75 / 60	454
CJTHT/ATEX-125-6T/6-10/CAT3	970		15,20	8,83	7,50	20	72250	74	458
CJTHT/ATEX-125-6/12T/6-10/CAT3	975 / 490		13,6 / 5,69		7,20 / 1,80	20	72250 / 36310	74 / 60	466
CJTHT/ATEX-125-6T/6-15/CAT3	970		22,50	13,07	11,00	26	85450	74	475
CJTHT/ATEX-125-6/12T/6-15/CAT3	975 / 485		23,1 / 8,41		11,00 / 3,00	26	85450 / 42510	74 / 59	566
CJTHT/ATEX-125-6T/6-20/CAT3	970		29,00	16,78	15,00	30	92860	76	542
CJTHT/ATEX-125-6/12T/6-24/CAT3	980 / 485		41,60 / 13,21		17,60 / 2,85	34	99650 / 49320	78 / 63	631
CJTHT/ATEX-125-6T/9-10/CAT3	970		15,20	8,83	7,50	14	63490	77	467
CJTHT/ATEX-125-6/12T/9-10/CAT3	975 / 490		13,6 / 5,69		7,20 / 1,80	14	63490 / 31910	77 / 63	475
CJTHT/ATEX-125-6T/9-15/CAT3	970		22,50	13,07	11,00	20	77550	75	484
CJTHT/ATEX-125-6/12T/9-15/CAT3	975 / 485		23,1 / 8,41		11,00 / 3,00	20	77550 / 38580	75 / 60	575
CJTHT/ATEX-125-6T/9-20/CAT3	970		29,00	16,78	15,00	26	92950	75	551
CJTHT/ATEX-125-6/12T/9-24/CAT3	980 / 485		41,60 / 13,21		17,60 / 2,85	30	98530 / 48760	76 / 61	640
CJTHT/ATEX-125-6T/9-25/CAT3	975		36,10	20,77	18,50	32	101450	77	627
CJTHT/ATEX-125-6T/9-30/CAT3	975		42,30	24,35	22,00	36	106525	80	638
CJTHT/ATEX-125-6T/12-10/CAT3	970		15,20	8,83	7,50	12	49630	79	476
CJTHT/ATEX-125-6T/12-15/CAT3	970		22,50	13,07	11,00	18	67315	77	493
CJTHT/ATEX-125-6T/12-20/CAT3	970		29,00	16,78	15,00	24	81840	76	560
CJTHT/ATEX-125-6T/12-25/CAT3	975		36,10	20,77	18,50	30	96765	77	636
CJTHT/ATEX-125-6T/12-30/CAT3	975		42,30	24,35	22,00	32	102040	78	647
CJTHT/ATEX-125-6T/12-40/CAT3	985		56,00	32,50	30,00	34	106355	79	762

¹ Los valores de los niveles sonoros, son presiones en dB(A) medidos a 3 metros, en campo libre.

Características acústicas

Espectro de potencia sonora Lw(A) en dB(A) por banda de frecuencia en Hz
Valores tomados a la aspiración con caudal máximo

	63	125	250	500	1000	2000	4000	8000		63	125	250	500	1000	2000	4000	8000
40-2-1.5	47	63	75	83	88	86	82	75	56-12-0.75 (2V)	29	39	49	53	54	52	45	37
40-4-1.5 (2V)	32	48	60	68	73	71	67	60	63-4-1	48	64	76	82	84	81	74	66
40-4-0.75	37	53	63	70	71	68	67	68	63-4-1.5	47	63	75	81	83	80	73	65
40-6-0.75	28	44	54	61	62	59	58	59	63-8-1.5 (2V)	31	47	59	65	67	64	57	49
40-12-0.75 (2V)	12	28	38	45	46	43	42	43	63-4-2	54	66	75	81	81	81	75	67
45-2-2	47	60	74	86	87	86	82	74	63-8-2 (2V)	39	51	60	66	66	66	60	52
45-4-2 (2V)	32	45	59	71	72	71	67	59	63-4-3	56	68	77	83	83	83	77	69
45-4-0.75	47	59	67	73	73	73	68	60	63-8-3 (2V)	41	53	62	68	68	68	62	54
45-6-0.75	37	49	57	63	63	63	58	50	63-4-4	57	69	78	84	84	84	78	70
45-12-0.75 (2V)	21	33	41	47	47	47	42	34	63-8-4 (2V)	42	54	63	69	69	69	63	55
50-4-0.75	49	61	69	75	75	75	70	62	63-6-0.75	48	58	68	72	73	71	64	56
50-6-0.75	41	53	61	67	67	67	62	54	63-12-0.75 (2V)	32	42	52	56	57	55	48	40
56-4-1	51	63	72	78	78	78	72	64	63-6-1	49	59	69	73	74	72	65	57
56-4-1.5	51	63	72	78	78	78	72	64	63-12-1 (2V)	33	43	53	57	58	56	49	41
56-8-1.5 (2V)	35	47	56	62	62	62	56	48	71-4-1.5	57	73	80	86	86	86	82	74
56-4-2	52	64	73	79	79	79	73	65	71-8-1.5 (2V)	41	57	64	70	70	70	66	58
56-6-0.75	45	55	65	69	70	68	61	53	71-4-2	56	72	79	85	85	85	81	73

Características acústicas

Espectro de potencia sonora Lw(A) en dB(A) por banda de frecuencia en Hz
Valores tomados a la aspiración con caudal máximo

	63	125	250	500	1000	2000	4000	8000		63	125	250	500	1000	2000	4000	8000
71-8-2 (2V)	41	57	64	70	70	70	66	58	100-12-4 (2V)	41	56	66	69	70	67	59	51
71-4-3	56	72	79	85	85	85	81	73	100-6-5.5	57	72	82	85	86	83	75	67
71-8-3 (2V)	41	57	64	70	70	70	66	58	100-6/9-5.5	57	72	82	85	86	83	75	67
71-4-4	63	75	79	85	85	86	83	75	100-6/9-7.5	58	73	83	86	87	84	76	68
71-8-4 (2V)	48	60	64	70	70	71	68	60	100-6/9-10	61	76	86	89	90	87	79	71
71-6-0.75	46	53	73	76	76	71	63	55	125-4/6-20	69	85	96	103	104	102	95	87
71-12-0.75 (2V)	30	37	57	60	60	55	47	39	125-8/6-20 (2V)	54	70	81	88	89	87	80	72
71-6-1	46	64	73	76	76	71	64	55	125-4/6-25	68	84	95	102	103	101	94	86
71-12-1 (2V)	30	48	57	60	60	55	48	39	125-4/6-27	67	83	94	101	102	100	93	85
71-6-1.5	47	65	74	77	77	72	65	56	125-8/6-27 (2V)	52	68	79	86	87	85	78	70
71-12-1.5 (2V)	31	49	58	61	61	56	49	40	125-4/6-30	67	83	94	101	102	100	93	85
80-4-3	55	71	84	91	91	88	82	74	125-4/6-37	67	83	94	101	102	100	93	85
80-8-3 (2V)	40	56	69	76	76	73	67	59	125-8/6-37 (2V)	52	68	79	86	87	85	78	70
80-4-4	54	70	83	90	90	87	81	73	125-4/6-40	67	83	94	101	102	100	93	85
80-8-4 (2V)	39	55	68	75	75	72	66	58	125-4/6-50	67	83	94	101	102	100	93	85
80-4-5.5	53	69	82	89	89	86	80	72	125-4/6-60	67	83	94	101	102	100	93	85
80-8-5.5 (2V)	38	54	67	74	74	71	65	57	125-4/6-75	70	86	97	104	105	103	96	88
80-6-1.5	53	68	75	78	79	76	70	62	125-4/9-25	67	81	94	102	104	101	96	88
80-12-1.5 (2V)	37	52	59	62	63	60	54	46	125-4/9-27	66	80	93	101	103	100	95	87
80-6-2	59	69	75	79	80	78	73	65	125-8/9-27 (2V)	51	65	78	86	88	85	80	72
80-12-2 (2V)	43	53	59	63	64	62	57	49	125-4/9-30	66	80	93	101	103	100	95	87
80-6-3	60	70	76	80	81	79	74	66	125-4/9-37	65	79	92	100	102	99	94	86
80-12-3 (2V)	45	55	61	65	66	64	59	51	125-8/9-37 (2V)	50	64	77	85	87	84	79	71
80-8-0.75	46	59	67	72	74	71	64	53	125-4/9-40	65	79	92	100	102	99	94	86
80-8-1	47	60	68	73	75	72	65	54	125-4/9-50	65	79	92	100	102	99	94	86
90-4-4	61	77	88	94	95	93	88	80	125-4/9-60	73	86	95	99	101	100	96	89
90-8-4 (2V)	46	62	73	79	80	78	73	65	125-4/9-75	74	87	96	100	102	101	97	90
90-4-5.5	60	76	87	93	94	92	87	79	125-4/9-100	76	89	98	102	104	103	99	92
90-8-5.5 (2V)	45	61	72	78	79	77	72	64	125-4/12-50	66	80	93	101	103	100	95	87
90-4-7.5	59	75	86	92	93	91	86	78	125-4/12-60	66	80	93	101	103	100	95	87
90-8-7.5 (2V)	44	60	71	77	78	76	71	63	125-4/12-75	74	87	96	100	102	101	97	90
90-4-10	58	74	85	91	92	90	85	77	125-4/12-100	76	89	98	102	104	103	99	92
90-8-10 (2V)	43	59	70	76	77	75	70	62	125-6/6-5.5	64	79	89	92	93	90	85	77
90-6-2	52	67	78	82	82	78	71	63	125-6/6-7.5	62	77	87	90	91	88	83	75
90-12-2 (2V)	36	51	62	66	66	62	55	47	125-12/6-7.5 (2V)	47	62	72	75	76	73	68	60
90-6-3	52	67	78	82	82	78	71	63	125-6/6-10	61	76	86	89	90	87	82	74
90-12-3 (2V)	37	52	63	67	67	63	56	48	125-12/6-10 (2V)	46	61	71	74	75	72	67	59
90-6-4	60	70	80	85	85	82	76	68	125-6/6-15	61	76	86	89	90	87	82	74
90-12-4 (2V)	45	55	65	70	70	67	61	53	125-12/6-15 (2V)	46	61	71	74	75	72	67	59
90-8-1	42	63	70	75	78	74	67	56	125-6/6-20	63	78	88	91	92	89	84	76
90-8-2	51	66	73	78	81	77	70	59	125-6/6-24	65	80	90	93	94	91	86	78
90-8-3	53	67	74	79	82	78	71	60	125-12/6-24 (2V)	50	65	75	78	79	76	71	63
100-4-7.5	67	83	90	97	98	96	92	84	125-6/9-10	61	76	87	93	94	88	84	77
100-8-7.5 (2V)	52	68	75	82	83	81	77	69	125-12/9-10 (2V)	46	61	72	78	79	73	69	62
100-4-10	65	81	88	95	96	94	90	82	125-6/9-15	59	74	85	91	92	86	82	75
100-8-10 (2V)	50	66	73	80	81	79	75	67	125-12/9-15 (2V)	44	59	70	76	77	71	67	60
100-4-15	71	83	87	93	94	94	91	83	125-6/9-20	59	74	85	91	92	86	82	75
100-8-15 (2V)	56	68	72	78	79	79	76	68	125-6/9-24	60	75	86	92	93	87	83	76
100-4-20	72	84	88	94	95	95	92	84	125-12/9-24 (2V)	45	60	71	77	78	72	68	61
100-8-20 (2V)	57	69	73	79	80	80	77	69	125-6/9-25	61	76	87	93	94	88	84	77
100-4/9-15	65	81	88	95	96	94	90	82	125-6/9-30	64	79	90	96	97	91	87	80
100-4/9-20	72	84	88	94	95	95	92	84	125-6/12-10	63	78	89	95	96	90	86	79
100-4/9-25	72	84	88	94	95	95	92	84	125-6/12-15	61	76	87	93	94	88	84	77
100-4/9-30	74	86	90	96	97	97	94	86	125-6/12-20	60	75	86	92	93	87	83	76
100-6-3	57	72	82	85	86	83	75	67	125-6/12-25	61	76	87	93	94	88	84	77
100-12-3 (2V)	42	57	67	70	71	68	60	52	125-6/12-30	62	77	88	94	95	89	85	78
100-6-4	56	71	81	84	85	82	74	66	125-6/12-40	63	78	89	95	96	90	86	79

Dimensiones mm

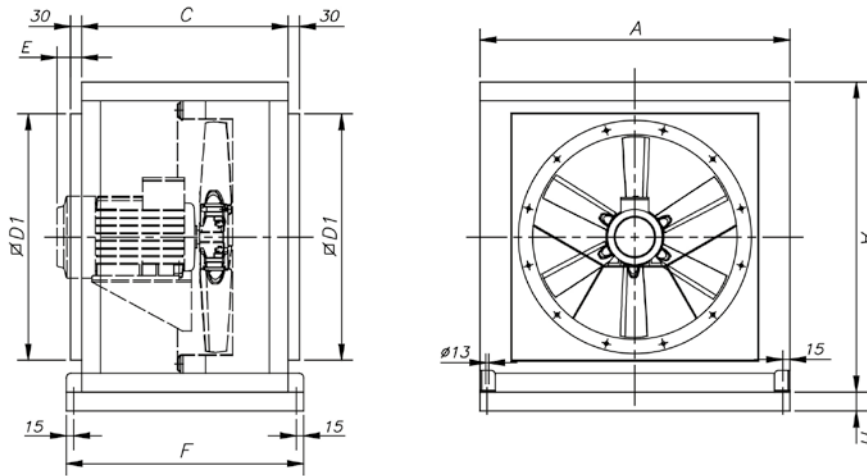

	A	C	ØD1	E	F	H
CJTHT/ATEX-40/45/50	700	550	565	-	630	-
CJTHT/ATEX-56/63	825	550	690	140	630	-
CJTHT/ATEX-71/80	1000	650	850	-	730	-
CJTHT/ATEX-90/100	1200	750	1050	-	830	-
CJTHT/ATEX-125 ≤20 CV	1600	1200	1400	-	1280	-
CJTHT/ATEX-125 >20 CV	1600	1200	1400	123	1280	100

Curvas características

Ver curvas características serie: THT

Accesorios



INT/ATEX



IAT



CABLE BOX



C2V



VSD3/A-RFT
- VSD1/A-RFM



CENTRAL CO



AET



P-400

THT/IMP

Jet fans de gran alcance 400 °C/2h y 300 °C/2h, unidireccionales o reversibles



THT/IMP-C



THT/IMP-O

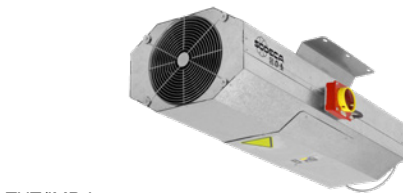

THT/IMP-L

Jet fans de gran alcance 300 °C/2h y 400 °C/2h unidireccionales o reversibles con diseño circular (THT/IMP-C), octogonal (THT/IMP-L) o octogonal pintada (THT/IMP-O).

Ventilador:

- Conjunto de ventilador unidireccional o reversible compuesto de ventilador, silenciadores, deflectores y soportes, homologados para evacuación de humos, según norma EN 12101-3, con certificación N°: 0370-CPR-1363 (F400) y 0370-CPR-0822 (F300).
- Hélice orientable en fundición de aluminio, diseñadas para obtener grandes empujes.
- Rejilla de protección contra contactos según norma UNE-EN ISO 12499 en los modelos unidireccionales.
- Deflector para aumento de alcance del aire, en el lado de impulsión. Los modelos reversibles van equipados con deflectores en ambos lados.
- Silenciadores de alta atenuación con aislamiento térmico y acústico.
- Interruptor de seguridad, serie IAT incorporado en el ventilador (THT/IMP-L y THT/IMP-O) o bajo demanda (THT/IMP-C).
- Dirección aire motor-hélice o reversible 100%.
- THT/IMP-C: Envoltorio circular en chapa de acero pintada.

- THT/IMP-L: Envoltorio en chapa de acero galvanizado.
- THT/IMP-O: Envoltorio en chapa pintada.
- THT/IMP-LS: Envoltorio de longitud reducida, en chapa de acero galvanizado.

Motor:

- Motores clase H para uso continuo S1 y uso emergencia S2. Con rodamientos a bolas, protección IP55 y 2 velocidades.
- Trifásico 400 V 50 Hz DAHLANDER.
- Temperatura máxima del aire a transportar: Servicio S1 -25 °C +40 °C en continuo, apto también para climas cálidos con temperaturas hasta 50 °C. Servicio S2 300 °C/2h, 400 °C/2h.

Acabado:

- Anticorrosivo en resina de poliéster polimerizada a 190 °C, previo desengrase con tratamiento nanotecnológico libre de fosfatos (THT/IMP-C, THT/IMP-O) o anticorrosivo en chapa de acero galvanizado (THT/IMP-L).

Bajo demanda:

- Prestaciones de empuje distintas a las indicadas.

Código de pedido

THT/IMP	-	O	-	UNI	-	38	-	2/4T	-	1.5	-	F400
THT/IMP: Jet fans de gran alcance 400 °C/2h y 300 °C/2h, unidireccionales o reversibles		Diseño: C: Envoltorio circular O: Envoltorio pintado L: Envoltorio chapa galvanizada LS: Envoltorio reducida		Dirección del aire UNI: Unidireccional REV: Reversible		Diámetro hélice en cm		Número de polos motor 2=2900 r/min 50 Hz 4=1400 r/min 50 Hz	T = Trifásico	Potencia motor (CV)		F300: Homologación 300 °C/2h F400: Homologación 400 °C/2h

Características técnicas

Unidireccional								
Modelo	Velocidad	Intensidad máxima admisible (A)	Caudal máximo	Empuje	Velocidad impulsión	Potencia instalada	Nivel presión sonora ¹	Peso aprox.
	(r/min)	400V	(m ³ /h)	(N)	(m/s)	(kW)	dB (A)	(Kg)
THT/IMP-C-UNI-31-2/4T	2780 / 1380	1,50 / 0,60	4260 / 2115	21 / 10	15,6 / 7,7	0,55 / 0,15	51 / 35	65
THT/IMP-C-UNI-35-2/4T	2905 / 1445	2,40 / 0,77	6360 / 3165	36 / 18	17,8 / 8,9	0,85 / 0,20	52 / 36	70
THT/IMP-C-UNI-38-2/4T-1.5	2900 / 1435	2,89 / 1,04	8450 / 4180	57 / 28	20,7 / 10,2	1,10 / 0,25	47 / 31	89
THT/IMP-C-UNI-40-2/4T-1.5	2900 / 1435	2,89 / 1,04	9250 / 4585	60 / 30	20,4 / 10,1	1,10 / 0,25	53 / 37	98
THT/IMP-C-UNI-45-2/4T-2	2875 / 1430	3,58 / 1,19	10800 / 5375	62 / 31	18,1 / 9,0	1,50 / 0,37	57 / 41	132
THT/IMP-C-UNI-45-2/4T-3	2885 / 1435	4,79 / 1,54	13200 / 6570	92 / 46	22,1 / 11,0	2,20 / 0,60	58 / 42	133
THT/IMP-C-UNI-50-2/4T-6	2915 / 1445	9,50 / 2,80	19700 / 9770	165 / 82	26,4 / 13,1	4,50 / 1,30	60 / 44	220
THT/IMP-O-UNI-29-2/4T	2780 / 1380	1,50 / 0,60	4000 / 1990	21 / 10	16,8 / 8,3	0,55 / 0,15	37 / 21	69
THT/IMP-O-UNI-35-2/4T	2905 / 1445	2,40 / 0,77	6360 / 3165	36 / 18	17,8 / 8,9	0,85 / 0,20	52 / 36	70
THT/IMP-O-UNI-38-2/4T-1.5	2900 / 1435	2,89 / 1,04	8450 / 4185	57 / 28	20,7 / 10,2	1,10 / 0,25	47 / 31	94
THT/IMP-O-UNI-40-2/4T-1.5	2900 / 1435	2,89 / 1,04	9250 / 4580	60 / 30	20,4 / 10,1	1,10 / 0,25	53 / 37	104
THT/IMP-O-UNI-45-2/4T-2	2875 / 1430	3,58 / 1,19	10800 / 5375	62 / 31	18,1 / 9,0	1,50 / 0,37	57 / 41	140
THT/IMP-O-UNI-45-2/4T-3	2885 / 1435	4,79 / 1,54	13200 / 6570	92 / 46	22,1 / 11,0	2,20 / 0,60	58 / 42	141
THT/IMP-O-UNI-50-2/4T-6	2915 / 1445	9,50 / 2,80	19700 / 9770	165 / 82	26,4 / 13,1	4,50 / 1,30	60 / 44	234
THT/IMP-L-UNI-29-2/4T	2780 / 1380	1,50 / 0,60	4000 / 1990	21 / 10	16,8 / 8,3	0,55 / 0,15	37 / 21	69
THT/IMP-L-UNI-35-2/4T	2905 / 1445	2,40 / 0,77	6360 / 3165	36 / 18	17,8 / 8,9	0,85 / 0,20	52 / 36	70
THT/IMP-L-UNI-38-2/4T-1.5	2900 / 1435	2,89 / 1,04	8450 / 4185	57 / 28	20,7 / 10,2	1,10 / 0,25	47 / 31	94
THT/IMP-L-UNI-40-2/4T-1.5	2900 / 1435	2,89 / 1,04	9250 / 4580	60 / 30	20,4 / 10,1	1,10 / 0,25	53 / 37	104
THT/IMP-L-UNI-45-2/4T-2	2875 / 1430	3,58 / 1,19	10800 / 5375	62 / 31	18,1 / 9,0	1,50 / 0,37	57 / 41	140
THT/IMP-L-UNI-45-2/4T-3	2885 / 1435	4,79 / 1,54	13200 / 6570	92 / 46	22,1 / 11,0	2,20 / 0,60	58 / 42	141
THT/IMP-L-UNI-50-2/4T-6	2915 / 1445	9,50 / 2,80	19700 / 9770	165 / 82	26,4 / 13,1	4,50 / 1,30	60 / 44	234
THT/IMP-LS-UNI-29-2/4T	2780 / 1380	1,50 / 0,60	4000 / 1990	21 / 10	16,8 / 8,3	0,55 / 0,15	39 / 23	55
THT/IMP-LS-UNI-35-2/4T	2905 / 1445	2,40 / 0,77	6360 / 3165	36 / 18	17,8 / 8,9	0,85 / 0,20	54 / 38	56
THT/IMP-LS-UNI-38-2/4T-1.5	2900 / 1435	2,89 / 1,04	8450 / 4185	57 / 28	20,7 / 10,2	1,10 / 0,25	49 / 33	76
THT/IMP-LS-UNI-40-2/4T-1.5	2900 / 1435	2,89 / 1,04	9250 / 4580	60 / 30	20,4 / 10,1	1,10 / 0,25	55 / 39	83
THT/IMP-LS-UNI-45-2/4T-2	2875 / 1430	3,58 / 1,19	10800 / 5375	62 / 31	18,1 / 9,0	1,50 / 0,37	59 / 43	112
THT/IMP-LS-UNI-45-2/4T-3	2885 / 1435	4,79 / 1,54	13200 / 6570	92 / 46	22,1 / 11,0	2,20 / 0,60	60 / 44	113
THT/IMP-LS-UNI-50-2/4T-6	2915 / 1445	9,50 / 2,80	19700 / 9770	165 / 82	26,4 / 13,1	4,50 / 1,30	62 / 46	187

¹ Nivel de presión sonora en dB(A) a 10 m de distancia a caudal máximo.

Reversible								
Modelo	Velocidad	Intensidad máxima admisible (A)	Caudal máximo	Empuje	Velocidad impulsión	Potencia instalada	Nivel presión sonora ¹	Peso aprox.
	(r/min)	400V	(m ³ /h)	(N)	(m/s)	(kW)	dB (A)	(Kg)
THT/IMP-C-REV-31-2/4T	2780 / 1380	1,50 / 0,60	3840 / 1910	17 / 8	14,1 / 7,0	0,55 / 0,15	50 / 34	63
THT/IMP-C-REV-35-2/4T	2905 / 1445	2,40 / 0,77	5940 / 2955	31 / 15	16,7 / 8,3	0,85 / 0,20	51 / 35	70
THT/IMP-C-REV-38-2/4T-2	2875 / 1430	3,58 / 1,19	8200 / 4080	54 / 27	20,1 / 10,0	1,50 / 0,37	49 / 33	91
THT/IMP-C-REV-40-2/4T-2	2875 / 1430	3,58 / 1,19	9250 / 4605	60 / 30	20,4 / 10,1	1,50 / 0,37	52 / 36	100
THT/IMP-C-REV-45-2/4T-2	2875 / 1430	3,58 / 1,19	10300 / 5125	56 / 28	17,2 / 8,6	1,50 / 0,37	56 / 40	131
THT/IMP-C-REV-45-2/4T-3	2885 / 1435	4,79 / 1,54	12800 / 6370	87 / 43	21,4 / 10,6	2,20 / 0,60	57 / 41	133
THT/IMP-C-REV-50-2/4T-6	2915 / 1445	9,50 / 2,80	19000 / 9420	153 / 76	25,4 / 12,6	4,50 / 1,30	60 / 44	267
THT/IMP-O-REV-29-2/4T	2780 / 1380	1,50 / 0,60	3400 / 1690	15 / 7	14,3 / 7,1	0,55 / 0,15	38 / 22	67
THT/IMP-O-REV-35-2/4T	2905 / 1445	2,40 / 0,77	5940 / 2955	31 / 15	16,7 / 8,3	0,85 / 0,20	51 / 35	70
THT/IMP-O-REV-38-2/4T-2	2875 / 1430	3,58 / 1,19	8200 / 4080	54 / 27	20,1 / 10	1,50 / 0,37	49 / 33	97
THT/IMP-O-REV-40-2/4T-2	2875 / 1430	3,58 / 1,19	9250 / 4605	60 / 30	20,4 / 10,1	1,50 / 0,37	52 / 36	106
THT/IMP-O-REV-45-2/4T-2	2875 / 1430	3,58 / 1,19	10300 / 5125	56 / 28	17,2 / 8,6	1,50 / 0,37	56 / 40	139
THT/IMP-O-REV-45-2/4T-3	2885 / 1435	4,79 / 1,54	12800 / 6370	87 / 43	21,4 / 10,6	2,20 / 0,60	57 / 41	141
THT/IMP-O-REV-50-2/4T-6	2915 / 1445	9,50 / 2,80	19000 / 9420	153 / 76	25,4 / 12,6	4,50 / 1,30	60 / 44	284
THT/IMP-L-REV-29-2/4T	2780 / 1380	1,50 / 0,60	3400 / 1690	15 / 7	14,3 / 7,1	0,55 / 0,15	38 / 22	67
THT/IMP-L-REV-35-2/4T	2905 / 1445	2,40 / 0,77	5940 / 2955	31 / 15	16,7 / 8,3	0,85 / 0,20	51 / 35	70
THT/IMP-L-REV-38-2/4T-2	2875 / 1430	3,58 / 1,19	8200 / 4080	54 / 27	20,1 / 10,0	1,50 / 0,37	49 / 33	97
THT/IMP-L-REV-40-2/4T-2	2875 / 1430	3,58 / 1,19	9250 / 4605	60 / 30	20,4 / 10,1	1,50 / 0,37	52 / 36	106

Características técnicas

Modelo	Velocidad (r/min)	Intensidad máxima admisible (A)	Caudal máximo (m³/h)	Empuje (N)	Velocidad impulsión (m/s)	Potencia instalada (kW)	Nivel presión sonora¹ (dB (A))	Peso aprox. (Kg)
		400V						
THT/IMP-L-REV-45-2/4T-2	2875 / 1430	3,58 / 1,19	10300 / 5125	56 / 28	17,2 / 8,6	1,50 / 0,37	56 / 40	139
THT/IMP-L-REV-45-2/4T-3	2885 / 1435	4,79 / 1,54	12800 / 6370	87 / 43	21,4 / 10,6	2,20 / 0,6	57 / 41	141
THT/IMP-L-REV-50-2/4T-6	2915 / 1445	9,50 / 2,80	19000 / 9420	153 / 76	25,4 / 12,6	4,50 / 1,30	60 / 44	284
THT/IMP-LS-REV-29-2/4T	2780 / 1380	1,50 / 0,60	3400 / 1690	15 / 7	14,3 / 7,1	0,55 / 0,15	40 / 24	55
THT/IMP-LS-REV-35-2/4T	2905 / 1445	2,40 / 0,77	5940 / 2955	31 / 15	16,7 / 8,3	0,85 / 0,20	53 / 37	56
THT/IMP-LS-REV-38-2/4T-2	2875 / 1430	3,58 / 1,19	8200 / 4080	54 / 27	20,1 / 10,0	1,50 / 0,37	51 / 35	77
THT/IMP-LS-REV-40-2/4T-2	2875 / 1430	3,58 / 1,19	9250 / 4605	60 / 30	20,4 / 10,1	1,50 / 0,37	53 / 37	85
THT/IMP-LS-REV-45-2/4T-2	2875 / 1430	3,58 / 1,19	10300 / 5125	56 / 28	17,2 / 8,6	1,50 / 0,37	58 / 42	111
THT/IMP-LS-REV-45-2/4T-3	2885 / 1435	4,79 / 1,54	12800 / 6370	87 / 43	21,4 / 10,6	2,20 / 0,60	59 / 43	113
THT/IMP-LS-REV-50-2/4T-6	2915 / 1445	9,50 / 2,80	19000 / 9420	153 / 76	25,4 / 12,6	4,50 / 1,30	62 / 46	227

1 Nivel de presión sonora en dB(A) a 10 m de distancia a caudal máximo.

Características acústicas

Espectro de potencia sonora Lw(A) en dB(A) por banda de frecuencia en Hz

	63	125	250	500	1000	2000	4000	8000		63	125	250	500	1000	2000	4000	8000
THT/IMP-C-UNI-31-2/4T	53	59	77	66	69	68	66	57	THT/IMP-C-REV-31-2/4T	52	58	76	65	68	67	65	56
THT/IMP-C-UNI-31-2/4T (2V)	37	43	61	50	53	52	50	41	THT/IMP-C-REV-31-2/4T (2V)	36	42	60	49	52	51	49	40
THT/IMP-C-UNI-35-2/4T	54	60	78	67	70	69	67	58	THT/IMP-C-REV-35-2/4T	53	59	77	66	69	68	66	57
THT/IMP-C-UNI-35-2/4T (2V)	38	44	62	51	54	53	51	42	THT/IMP-C-REV-35-2/4T (2V)	37	43	61	50	53	52	50	41
THT/IMP-C-UNI-38-2/4T-1.5	49	55	73	62	65	64	62	53	THT/IMP-C-REV-38-2/4T-2	51	57	75	64	67	66	64	55
THT/IMP-C-UNI-38-2/4T-1.5 (2V)	33	39	57	46	49	48	46	37	THT/IMP-C-REV-38-2/4T-2 (2V)	35	41	59	48	51	50	48	39
THT/IMP-C-UNI-40-2/4T-1.5	55	61	79	68	71	70	68	59	THT/IMP-C-REV-40-2/4T-2	54	60	78	67	70	69	67	58
THT/IMP-C-UNI-40-2/4T-1.5 (2V)	39	45	63	52	55	54	52	43	THT/IMP-C-REV-40-2/4T-2 (2V)	38	44	62	51	54	53	51	42
THT/IMP-C-UNI-45-2/4T-2	59	65	83	72	75	74	72	63	THT/IMP-C-REV-45-2/4T-2	58	64	82	71	74	73	71	62
THT/IMP-C-UNI-45-2/4T-2 (2V)	43	49	67	56	59	58	56	47	THT/IMP-C-REV-45-2/4T-2 (2V)	42	48	66	55	58	57	55	46
THT/IMP-C-UNI-45-2/4T-3	60	66	84	73	76	75	73	64	THT/IMP-C-REV-45-2/4T-3	59	65	83	72	75	74	72	63
THT/IMP-C-UNI-45-2/4T-3 (2V)	44	50	68	57	60	59	57	48	THT/IMP-C-REV-45-2/4T-3 (2V)	43	49	67	56	59	58	56	47
THT/IMP-C-UNI-50-2/4T-6	62	68	86	75	78	77	75	66	THT/IMP-C-REV-50-2/4T-6	62	68	86	75	78	77	75	66
THT/IMP-C-UNI-50-2/4T-6 (2V)	46	52	70	59	62	61	59	50	THT/IMP-C-REV-50-2/4T-6 (2V)	46	52	70	59	62	61	59	50
THT/IMP-O-UNI-29-2/4T	39	45	63	52	55	54	52	43	THT/IMP-O-REV-29-2/4T	40	46	64	53	56	55	53	44
THT/IMP-O-UNI-29-2/4T (2V)	23	29	47	36	39	38	36	27	THT/IMP-O-REV-29-2/4T (2V)	24	30	48	37	40	39	37	28
THT/IMP-O-UNI-35-2/4T	54	60	78	67	70	69	67	58	THT/IMP-O-REV-35-2/4T	53	59	77	66	69	68	66	57
THT/IMP-O-UNI-35-2/4T (2V)	38	44	62	51	54	53	51	42	THT/IMP-O-REV-35-2/4T (2V)	37	43	61	50	53	52	50	41
THT/IMP-O-UNI-38-2/4T-1.5	49	55	73	62	65	64	62	53	THT/IMP-O-REV-38-2/4T-2	51	57	75	64	67	66	64	55
THT/IMP-O-UNI-38-2/4T-1.5 (2V)	33	39	57	46	49	48	46	37	THT/IMP-O-REV-38-2/4T-2 (2V)	35	41	59	48	51	50	48	39
THT/IMP-O-UNI-40-2/4T-1.5	55	61	79	68	71	70	68	59	THT/IMP-O-REV-40-2/4T-2	54	60	78	67	70	69	67	58
THT/IMP-O-UNI-40-2/4T-1.5 (2V)	39	45	63	52	55	54	52	43	THT/IMP-O-REV-40-2/4T-2 (2V)	38	44	62	51	54	53	51	42
THT/IMP-O-UNI-45-2/4T-2	59	65	83	72	75	74	72	63	THT/IMP-O-REV-45-2/4T-2	58	64	82	71	74	73	71	62
THT/IMP-O-UNI-45-2/4T-2 (2V)	43	49	67	56	59	58	56	47	THT/IMP-O-REV-45-2/4T-2 (2V)	42	48	66	55	58	57	55	46
THT/IMP-O-UNI-45-2/4T-3	60	66	84	73	76	75	73	64	THT/IMP-O-REV-45-2/4T-3	59	65	83	72	75	74	72	63
THT/IMP-O-UNI-45-2/4T-3 (2V)	44	50	68	57	60	59	57	48	THT/IMP-O-REV-45-2/4T-3 (2V)	43	49	67	56	59	58	56	47
THT/IMP-O-UNI-50-2/4T-6	62	68	86	75	78	77	75	66	THT/IMP-O-REV-50-2/4T-6	62	68	86	75	78	77	75	66
THT/IMP-O-UNI-50-2/4T-6 (2V)	46	52	70	59	62	61	59	50	THT/IMP-O-REV-50-2/4T-6 (2V)	46	52	70	59	62	61	59	50
THT/IMP-L-UNI-29-2/4T	39	45	63	52	55	54	52	43	THT/IMP-L-REV-29-2/4T	40	46	64	53	56	55	53	44
THT/IMP-L-UNI-29-2/4T (2V)	23	29	47	36	39	38	36	27	THT/IMP-L-REV-29-2/4T (2V)	24	30	48	37	40	39	37	28
THT/IMP-L-UNI-35-2/4T	54	60	78	67	70	69	67	58	THT/IMP-L-REV-35-2/4T	53	59	77	66	69	68	66	57
THT/IMP-L-UNI-35-2/4T (2V)	38	44	62	51	54	53	51	42	THT/IMP-L-REV-35-2/4T (2V)	37	43	61	50	53	52	50	41
THT/IMP-L-UNI-38-2/4T-1.5	49	55	73	62	65	64	62	53	THT/IMP-L-REV-38-2/4T-2	51	57	75	64	67	66	64	55
THT/IMP-L-UNI-38-2/4T-1.5 (2V)	33	39	57	46	49	48	46	37	THT/IMP-L-REV-38-2/4T-2 (2V)	35	41	59	48	51	50	48	39
THT/IMP-L-UNI-40-2/4T-1.5	55	61	79	68	71	70	68	59	THT/IMP-L-REV-40-2/4T-2	54	60	78	67	70	69	67	58
THT/IMP-L-UNI-40-2/4T-1.5 (2V)	39	45	63	52	55	54	52	43	THT/IMP-L-REV-40-2/4T-2 (2V)	38	44	62	51	54	53	51	42
THT/IMP-L-UNI-45-2/4T-2	59	65	83	72	75	74	72	63	THT/IMP-L-REV-45-2/4T-2	58	64	82	71	74	73	71	62
THT/IMP-L-UNI-45-2/4T-2 (2V)	43	49	67	56	59	58	56	47	THT/IMP-L-REV-45-2/4T-2 (2V)	42	48	66	55	58	57	55	46
THT/IMP-L-UNI-45-2/4T-3	60	66	84	73	76	75	73	64	THT/IMP-L-REV-45-2/4T-3	59	65	83	72	75	74	72	63
THT/IMP-L-UNI-45-2/4T-3 (2V)	44	50	68	57	60	59	57	48	THT/IMP-L-REV-45-2/4T-3 (2V)	43	49	67	56	59	58	56	47
THT/IMP-L-UNI-50-2/4T-6	62	68	86	75	78	77	75	66	THT/IMP-L-REV-50-2/4T-6	62	68	86	75	78	77	75	66
THT/IMP-L-UNI-50-2/4T-6 (2V)	46	52	70	59	62	61	59	50	THT/IMP-L-REV-50-2/4T-6 (2V)	46	52	70	59	62	61	59	50
THT/IMP-LS-UNI-29-2/4T	41	47	65	54	57	56	54	45	THT/IMP-LS-REV-29-2/4T	42	48	66	55	58	57	55	46
THT/IMP-LS-UNI-29-2/4T (2V)	25	31	49	38	41	40	38	29	THT/IMP-LS-REV-29-2/4T (2V)	26	32	50	39	42	41	39	30
THT/IMP-LS-UNI-35-2/4T	56	62	80	69	72	71	69	60	THT/IMP-LS-REV-35-2/4T	55	61	79	68	71	70	68	59
THT/IMP-LS-UNI-35-2/4T (2V)	40	46	64	53	56	55	53	44	THT/IMP-LS-REV-35-2/4T (2V)	39	45	63	52	55	54	52	43
THT/IMP-LS-UNI-38-2/4T-1.5	51	57	75	64	67	66	64	55	THT/IMP-LS-REV-38-2/4T-2	53	59	77	66	69	68	66	57
THT/IMP-LS-UNI-38-2/4T-1.5 (2V)	35	41	59	48	51	50	48	39	THT/IMP-LS-REV-38-2/4T-2 (2V)	37	43	61	50	53	52	50	41
THT/IMP-LS-UNI-40-2/4T-1.5	57	63	81	70	73	72	70	61	THT/IMP-LS-REV-40-2/4T-2	55	61	79	68	71	70	68	59
THT/IMP-LS-UNI-40-2/4T-1.5 (2V)	41	47	65	54	57	56	54	45	THT/IMP-LS-REV-40-2/4T-2 (2V)	39	45	63	52	55	54	52	43
THT/IMP-LS-UNI-45-2/4T-2	61	67	85	74	77	76	74	65	THT/IMP-LS-REV-45-2/4T-2	60	66	84	73	76	75	73	64
THT/IMP-LS-UNI-45-2/4T-2 (2V)	45	51	69	58	61	60	58	49	THT/IMP-LS-REV-45-2/4T-2 (2V)	44	50	68	57	60	59	57	48
THT/IMP-LS-UNI-45-2/4T-3	62	68	86	75	78	77	75	66	THT/IMP-LS-REV-45-2/4T-3	61	67	85	74	77	76	74	65
THT/IMP-LS-UNI-45-2/4T-3 (2V)	46	52	70	59	62	61	59	50	THT/IMP-LS-REV-45-2/4T-3 (2V)	45	51	69	58	61	60	58	49
THT/IMP-LS-UNI-50-2/4T-6	64	70	88	77	80	79	77	68	THT/IMP-LS-REV-50-2/4T-6	64	70	88	77	80	79	77	68
THT/IMP-LS-UNI-50-2/4T-6 (2V)	48	54	72	61	64	63	61	52	THT/IMP-LS-REV-50-2/4T-6 (2V)	48	54	72	61	64	63	61	52

Dimensiones mm

C: Envoltorio circular

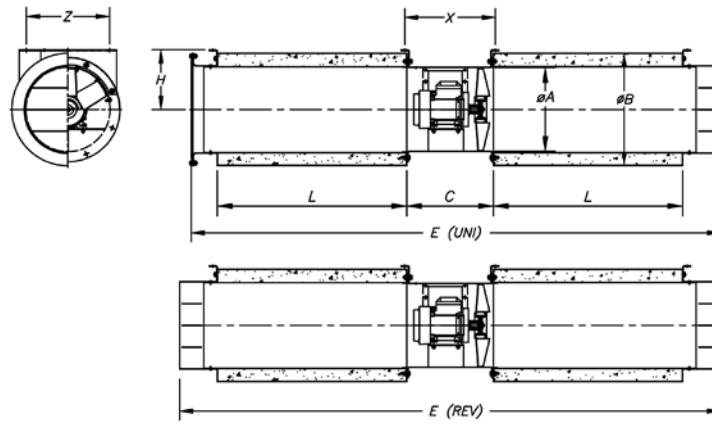

	ØA	ØB	C	L	Ød	E (UNI)	E (REV)	H	X	Z
THT/IMP-C-31	315	415	320	700	10	1956	2000	220	345	275
THT/IMP-C-35	355	460	325	700	12	1960	2005	250	346	300
THT/IMP-C-38	380	460	340	1000	12	2570	2620	250	530	517
THT/IMP-C-40	410	510	340	950	12	2485	2540	280	376	340
THT/IMP-C-45	460	630	360	950	12	2500	2554	355	396	440

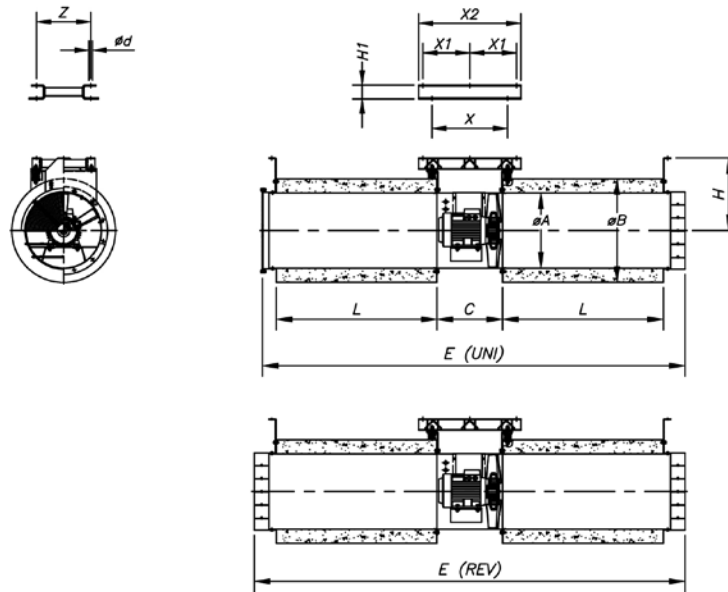

	ØA	ØB	C	L	Ød	E (UNI)	E (REV)	H	H1	X	X1	X2	Z
THT/IMP-C-50	514	710	450	1100	12	2895	2950	498	80	518	320	700	370

Dimensiones mm

O: Envolvente pintada
L: Envolvente chapa galvanizada
LS: Envolvente reducida

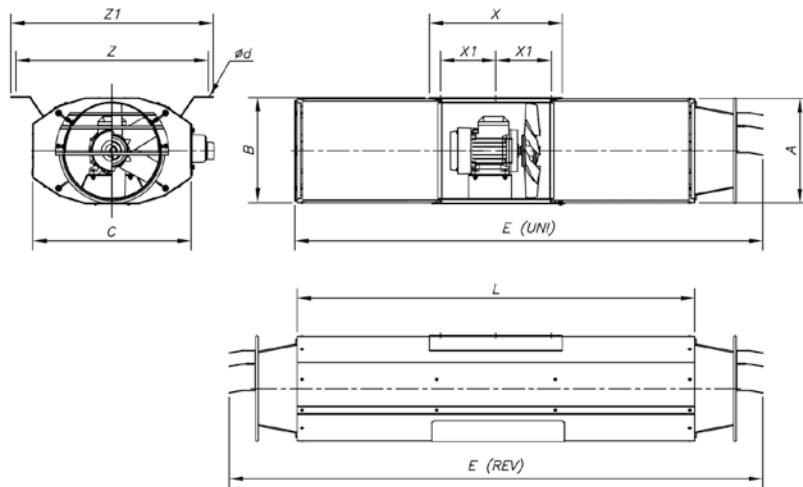

	A	B	C	ød	E (UNI)	E (REV)	L	X	X1	Z	Z1
THT/IMP-LS-29	319,5	324	479	12x26	1410	1610	1200	400	167	580	610
THT/IMP-L-29	319,5	324	479	12x26	2210	2410	2000	400	167	580	610
THT/IMP-O-29	319,5	324	479	12x26	2210	2410	2000	400	167	580	610
THT/IMP-LS-35	383	386	523	12x26	1410	1610	1200	400	167	614	644
THT/IMP-L-35	383	386	523	12x26	2210	2410	2000	400	167	614	644
THT/IMP-O-35	383	386	523	12x26	2210	2410	2000	400	167	614	644
THT/IMP-LS-38	406	409	550	12x26	1410	1610	1200	400	170	640	670
THT/IMP-L-38	406	409	550	12x26	2210	2410	2000	400	170	640	670
THT/IMP-O-38	406	409	550	12x26	2210	2410	2000	400	170	640	670
THT/IMP-LS-40	436	439	582	12x26	1410	1610	1200	400	170	670	700
THT/IMP-L-40	436	439	582	12x26	2210	2410	2000	400	170	670	700
THT/IMP-O-40	436	439	582	12x26	2210	2410	2000	400	170	670	700
THT/IMP-LS-45	486	489	630	12x26	1410	1610	1200	400	170	724	754
THT/IMP-L-45	486	489	630	12x26	2210	2410	2000	400	170	724	754
THT/IMP-O-45	486	489	630	12x26	2210	2410	2000	400	170	724	754
THT/IMP-LS-50	546	549	742	12x26	1445	1675	1200	560	255	778	808
THT/IMP-L-50	546	549	742	12x26	2245	2475	2000	560	255	778	808
THT/IMP-O-50	546	549	742	12x26	2245	2475	2000	560	255	778	808

Aplicación en garajes

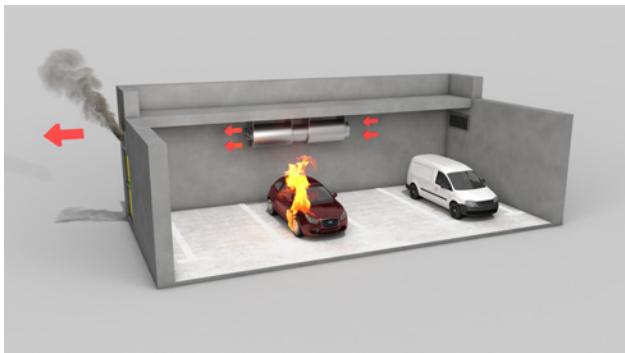

Instalación del Jet Fan en la zona de riesgo de incendio

Accesorios



Configuración con BOXPARK



Cuadros de control para sistemas de ventilación de aparcamientos con triple propósito: ventilación diaria, control de la concentración de CO y extracción de humo en caso de incendio

Cuadros de control en envoltorio metálica con todos los elementos necesarios para la gestión y control de los ventiladores de sistemas de ventilación de aparcamientos, ya estén basados en redes de conductos o en ventiladores de impulsos, para el control de los niveles de concentración de CO y la extracción de humo en caso de incendio. Cuadros a medida para todas las potencias y número de ventiladores según necesidades del proyecto.

Más información ver serie BOXPARK.

Ejemplos de instalación con BOXPARK

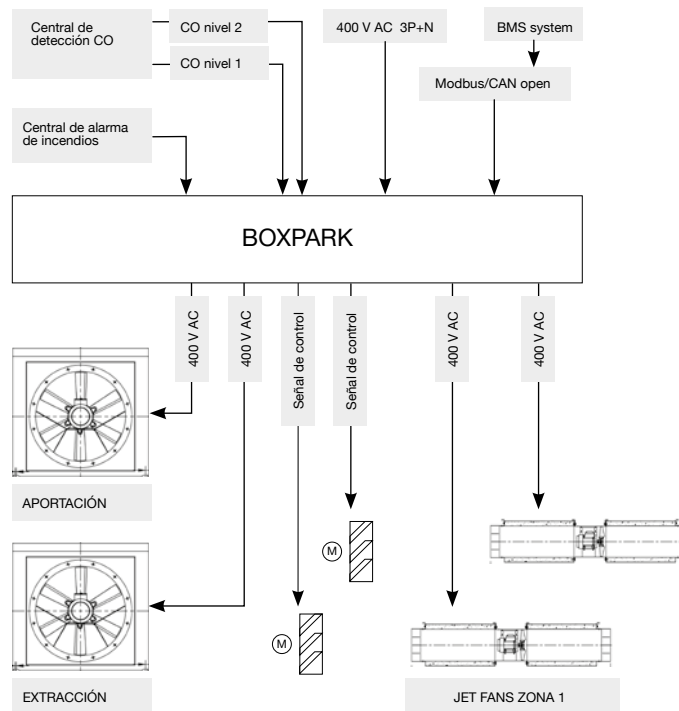

TUNEL JET FAN



Jet fans especialmente diseñados para ventilación de túneles. Certificados 400 °C/2h y 300 °C/2h según modelo



Jet fan unidireccional, de gran robustez y hélice en fundición de aluminio para empujes medios. Diseñados especialmente para la ventilación de túneles y para la evacuación de humo en caso de incendios certificados 400 °C/2h y 300 °C/2h según modelo.

Ventilador:

- Envoltente tubular en chapa de acero de gran espesor.
- Soporte de motor soldado al envoltente.
- Entrada aerodinámica y cono de descarga.
- Óptima protección superficial mediante acero de alta calidad.
- Hélice unidireccional, construida en fundición de aluminio.
- Silenciador tubular acoplado a ambos extremos que proporciona un alto aislamiento térmico y acústico.
- Base soporte especialmente diseñada para la sustentación de todo el conjunto. A partir del diámetro 560 mm incorpora muelles antivibratorios.
- Conexión eléctrica en caja de bornes externa.
- Cable tipo E90 con protección metálica.
- Pies soporte o bancada soporte según modelo, incluidos en el conjunto.
- Amortiguadores antivibratorios.
- Anclaje de seguridad incluido.
- Homologación según norma EN 12101-3.

Motor:

- Motores clase H para uso continuo S1 y uso emergencia S2. Con rodamientos a bolas y protección IP55.
- Motores con eficiencia IE3 para potencias iguales o superiores a 0,75 kW, excepto monofásicos, 2 velocidades y 8 polos.
- Trifásico 400/690 V 50 Hz.
- Temperatura máxima del aire a transportar: Servicio S1 -25 °C +40 °C en continuo, apto también para climas cálidos con temperaturas hasta 50 °C. Servicio S2 300 °C/2h, 400 °C/2h.

Acabado:

- Acero de alta protección anticorrosivo, imprimación especial y pintura de alta calidad para ambientes corrosivos.

Bajo demanda:

- Motores normalizados IP55, motores ATEX y de 2 velocidades.
- Construcción total en acero inoxidable.
- Construcción en acero galvanizado en caliente.

Código de pedido

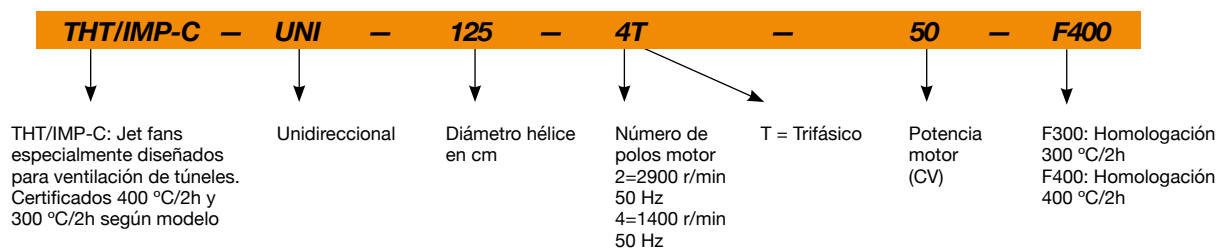

Características técnicas

Modelo	Velocidad (r/min)	Intensidad máxima admisible (A)			Caudal máximo (m³/h)	Empuje (N)	Velocidad impulsión (m/s)	Potencia instalada (kW)	Nivel presión sonora¹ dB (A)	Peso aprox. (Kg)
		230V	400V	690V						
THT/IMP-C-UNI-56-2T-12 IE3	2975		18,07	10,44	29500	312	37,6	9,2	64	273
THT/IMP-C-UNI-56-4T-2 IE3	1435	5,89	3,38		14550	76	16,4	1,5	50	197
THT/IMP-C-UNI-63-2T-20 IE3	2935		26,50	15,35	40050	455	37,1	15,0	68	323
THT/IMP-C-UNI-63-4T-3 IE3	1450	7,86	4,52		21550	132	19,2	2,2	53	241
THT/IMP-C-UNI-71-4T-4 IE3	1455	11,01	6,33		28550	182	20,0	3,0	65	279
THT/IMP-C-UNI-80-4T-5.5 IE3	1445		7,95	4,61	36900	239	20,4	4,0	63	414
THT/IMP-C-UNI-90-4T-10 IE3	1460		14,20	8,17	52000	375	22,7	7,5	65	495
THT/IMP-C-UNI-100-4T-15 IE3	1460		20,70	11,99	66500	497	23,5	11,0	63	667
THT/IMP-C-UNI-125-4T-30 IE3	1475		42,20	24,44	98100	692	22,2	22,0	59	980
THT/IMP-C-UNI-125-4T-50 IE3	1480		66,80	38,70	123700	1101	28,0	37,0	62	1110

1 Nivel de presión sonora en dB(A) a 10 m de distancia a caudal máximo.

Características acústicas

Espectro de potencia sonora Lw(A) en dB(A) por banda de frecuencia en Hz

	63	125	250	500	1000	2000	4000	8000		63	125	250	500	1000	2000	4000	8000
56-2T-12	66	72	90	79	82	81	79	70	80-4T-5.5	65	71	89	78	81	80	78	69
56-4T-2	52	58	76	65	68	67	65	56	90-4T-10	67	73	91	80	83	82	80	71
63-2T-20	70	76	94	83	86	85	83	74	100-4T-15	65	71	89	78	81	80	78	69
63-4T-3	55	61	79	68	71	70	68	59	125-4T-30	61	67	85	74	77	76	74	65
71-4T-4	67	73	91	80	83	82	80	71	125-4T-50	64	70	88	77	80	79	77	68

Dimensiones mm

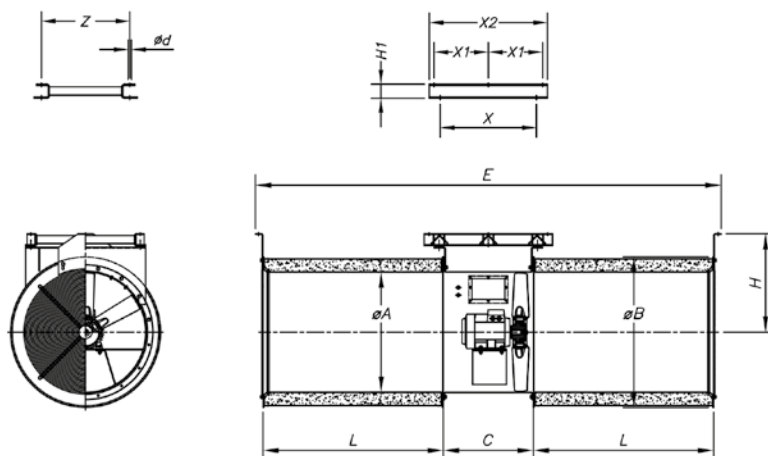

	ØA	ØB	C	L	Ød	E	H	H1	X	X1	X2	Z
THT/IMP-C-UNI-56	560	750	500	1200	12	3093	503	80	558	345	750	465
THT/IMP-C-UNI-63	640	800	650	1200	14	3242	525	80	706	418	900	545
THT/IMP-C-UNI-71	710	900	500	1200	14	3092	600	80	558	345	750	465
THT/IMP-C-UNI-80	800	1000	600	1200	14	3104	655	80	656	395	855	730
THT/IMP-C-UNI-90	900	1100	600	1200	14	3105	675	80	677	405,5	876	825
THT/IMP-C-UNI-100	1000	1200	700	1200	14	3205	730	80	767	450	965	884
THT/IMP-C-UNI-125	1250	1503	650	1350	17	3455	953	100	717	575	1250	1150

Curvas características

Q= Caudal en m³/h, m³/s y cfm

Pe= Presión estática en mmH₂O, Pa e inwg

— Presión - - - Empuje (N)

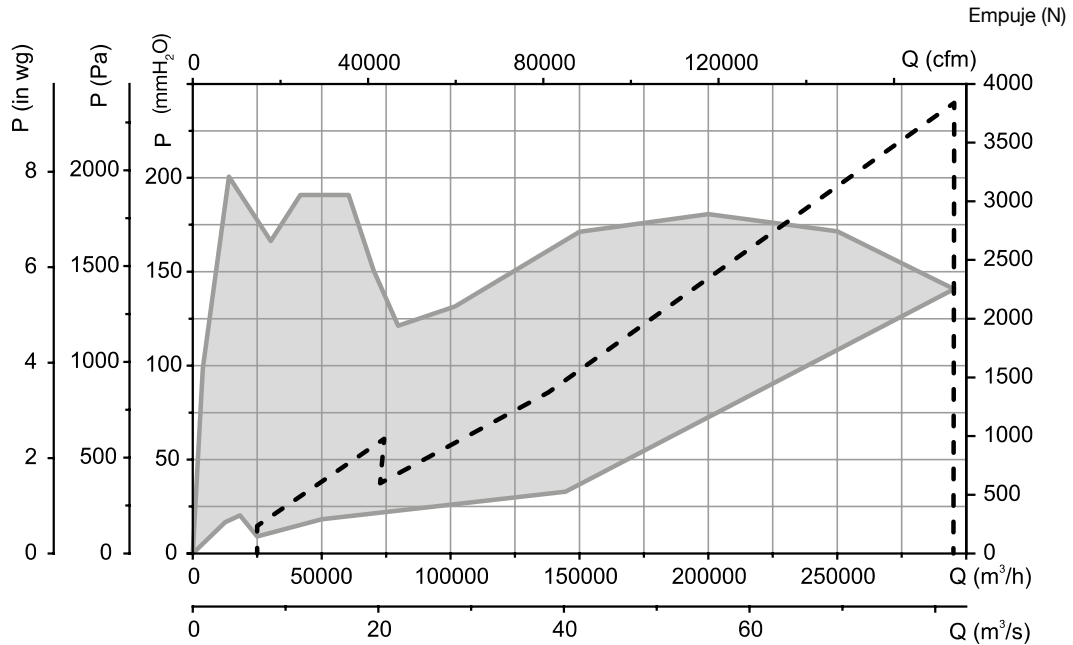

Ejemplo de aplicación



VENTILACIÓN LONGITUDINAL

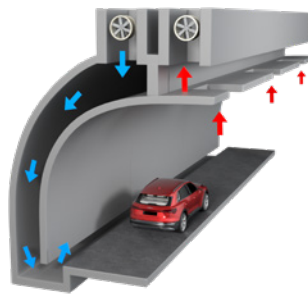

VENTILACIÓN TRANSVERSAL



VENTILACIÓN SEMITRANSVERSAL

Accesorios



CI



Jet fans centrífugos de inducción y de gran alcance 300 °C/2h y 400 °C/2h, para trabajar dentro de la zona de riesgo de incendio, con bajo perfil



Jet fans centrífugos de inducción y de gran alcance 300 °C/2h y 400 °C/2h, para trabajar dentro de la zona de riesgo de incendio, con bajo perfil.

Ventilador:

- Envoltente en chapa de acero.
- Turbina a reacción en chapa de acero de gran robustez.
- Interruptor de seguridad, serie IAT, incorporado en el ventilador.
- Pies fijación incluidos.

Motor:

- Motores clase H para uso continuo S1 y uso emergencia S2. Con rodamientos a bolas, protección IP55 y 1 o 2 velocidades según modelo.

- Trifásico 230/400 V 50 Hz.
- Temperatura máxima del aire a transportar: Servicio S1 -20 °C +40 °C en continuo, apto también para climas cálidos con temperaturas hasta 50 °C. Servicio S2 300 °C/2h, 400 °C/2h.

Acabado:

- Anticorrosivo en resina de poliéster polimerizada a 190 °C, previo desengrase con tratamiento nanotecnológico libre de fosfatos.

Código de pedido

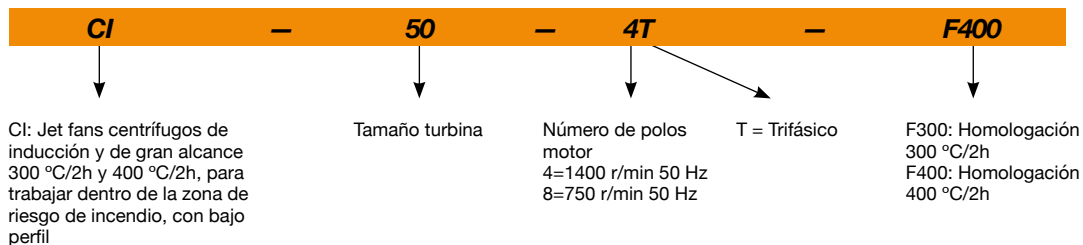

Características técnicas

Modelo	Velocidad (r/min)	Intensidad máxima admisible (A)		Caudal máximo (m ³ /h)	Empuje (N)	Velocidad impulsión (m/s)	Potencia instalada (kW)	Nivel presión sonora ¹ dB (A)	Peso aprox. (Kg)
		230V	400V						
CI-50-4T	1395	5,00	2,90	6050	50	23,5	1,20	64	83
CI-50-4/8T	1395 / 650		2,90 / 1,20	6050 / 2820	50 / 23	23,5 / 10,9	1,20 / 0,30	64 / 47	83
CI-75-4/8T	1450 / 730		5,20 / 2,05	8080 / 4070	75 / 38	26,3 / 13,2	2,20 / 0,37	65 / 50	139
CI-100-4T	1445	9,90	5,70	9340	100	30,0	2,40	67	141
CI-100-4/8T	1445 / 715		5,70 / 2,20	9340 / 4625	100 / 49	30,0 / 14,8	2,40 / 0,55	67 / 51	141

¹ Nivel de presión sonora en dB(A) a 10 m de distancia a caudal máximo.

Características acústicas

Espectro de potencia sonora Lw(A) en dB(A) por banda de frecuencia en Hz

	63	125	250	500	1000	2000	4000	8000		63	125	250	500	1000	2000	4000	8000	
CI-50-4T	63	75	82	86	88	85	81	75		CI-75-4/8T (2V)	50	67	69	73	74	68	64	60
CI-50-4/8T	63	75	82	86	88	85	81	75		CI-100-4T	68	85	87	89	90	85	80	73
CI-50-4/8T (2V)	46	58	65	69	71	68	64	58		CI-100-4/8T	68	85	87	89	90	85	80	73
CI-75-4/8T	65	82	84	88	89	83	79	75		CI-100-4/8T (2V)	52	69	71	73	74	69	64	57

Dimensiones mm

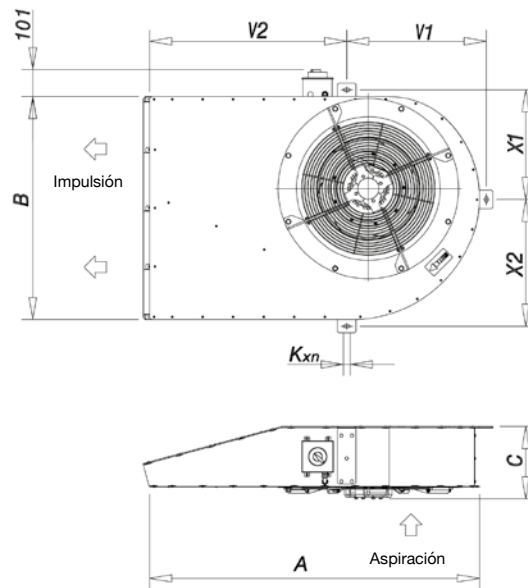

	A	B	C	V2	V1	X1	X2	Kxn
CI-50-F300	1240	840	272,5	741,5	524,5	413	477	12x26
CI-50-F400	1240	840	261,5	741,5	524,5	413	477	12x26
CI-75-F300	1778	1040	311	1143	662	494	596	12x26
CI-75-F400	1778	1040	299	1143	662	494	596	12x26
CI-100 F-300	1778	1040	323	1143	662	494	596	12x26
CI-100 F-400	1778	1040	323	1143	662	494	596	12x26

Accesorios



INT



IAT



CABLE BOX



C2V



AET



CENTRAL CO



VSD3/A-RFT
- VSD1/A-RFM



P-400



BOXPARK

Configuración con BOXPARK



Cuadros de control para sistemas de ventilación de aparcamientos con triple propósito: ventilación diaria, control de la concentración de CO y extracción de humo en caso de incendio

Cuadros de control en envoltorio metálica con todos los elementos necesarios para la gestión y control de los ventiladores de sistemas de ventilación de aparcamientos, ya estén basados en redes de conductos o en ventiladores de impulsos, para el control de los niveles de concentración de CO y la extracción de humo en caso de incendio. Cuadros a medida para todas las potencias y número de ventiladores según necesidades del proyecto.

Más información ver serie BOXPARK.

Ejemplos de instalación con BOXPARK

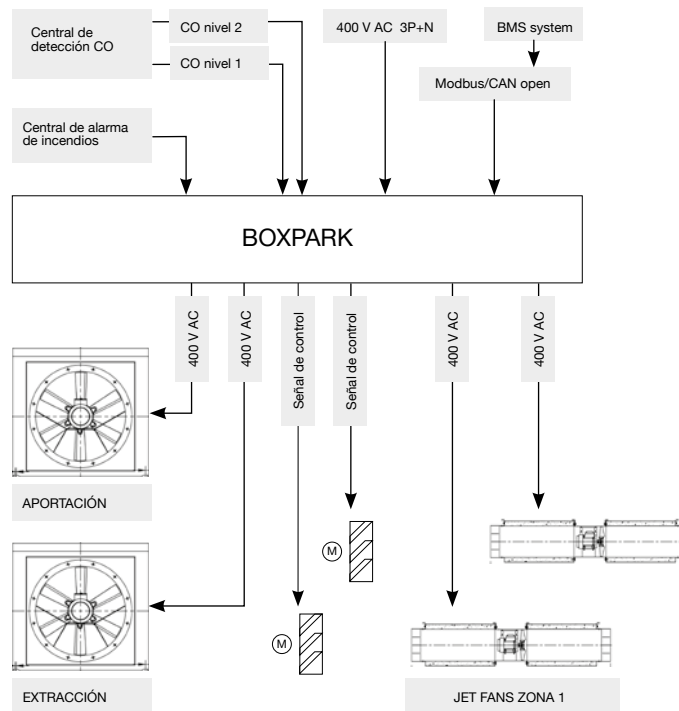

HTMF

Extractores de cubierta multifuncional 400 °C/2h (F400) y 300 °C/2h (F300)



Extractores de cubierta multifuncional 400 °C/2h y 300 °C/2h, para trabajar inmersos en zonas de riesgo de incendios, diseñados para evacuación de humos en naves industriales o similares.

Ventilador:

- Base soporte en chapa de acero galvanizada pintada.
- Hélice orientable en fundición de aluminio.
- Rejilla de protección contra contactos según norma UNE-EN ISO 12499.
- Sombrero en chapa de acero galvanizada pintada, con salida de aire natural. Homologación según norma EN 12101-3, con certificaciones N° 0370-CPR 0544 (F400) y 0370-CPR-3073 (F300).

Motor:

- Motores clase H para uso continuo S1 y uso emergencia S2. Con rodamientos a bolas, protección IP55 y 1 o 2 velocidades según modelo.
- Motores con eficiencia IE3 para potencias iguales o superiores a 0,75 kW, excepto monofásicos, 2 velocidades y 8 polos.
- Trifásico 230/400 V 50 Hz (hasta 3 kW) y 400/690 V 50 Hz (potencias superiores a 3 kW).
- Temperatura máxima del aire a transportar: Servicio S1 -20 °C +40 °C en continuo, apto también para climas cálidos con temperaturas hasta 50 °C. Servicio S2 300 °C/2h, 400 °C/2h.

Acabado:

- Anticorrosivo en resina de poliéster polimerizada a 190 °C, previo desengrase con tratamiento nanotecnológico libre de fosfatos.

Código de pedido

De tamaño 56 a tamaño 100

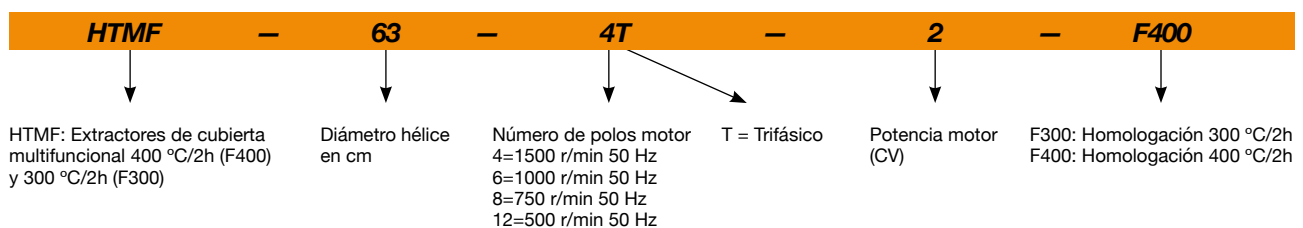

Tamaño 125

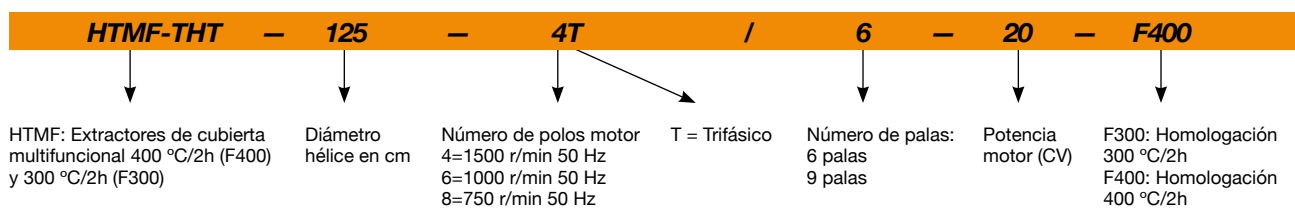

Características técnicas

Modelo	Velocidad (r/min)	Intensidad máxima admisible (A)			Potencia instalada (kW)	Caudal máximo (m³/h)	Nivel presión sonora¹ dB (A)		Peso aprox. (Kg)
		230V	400V	690V			Aspiración	Descarga	
HTMF-56-4T-1 IE3	1410	3,08	1,79		0,75	10640	54	51	79
HTMF-56-4T-1.5 IE3	1430	4,10	2,37		1,10	11530	55	52	79
HTMF-56-4/8T-1.5	1420 / 695		2,69 / 1,12		1,10 / 0,25	11530 / 5620	55 / 39	52 / 36	79
HTMF-56-6T-0.75	930	2,90	1,75		0,55	8255	43	41	80
HTMF-63-4T-1.5 IE3	1430	4,10	2,37		1,10	13930	57	54	94
HTMF-63-4/8T-1.5	1420 / 695		2,69 / 1,12		1,10 / 0,25	13930 / 6800	57 / 41	54 / 38	94
HTMF-63-4T-2 IE3	1435	5,89	3,38		1,50	15630	58	55	96
HTMF-63-4/8T-2	1430 / 725		3,40 / 1,65		1,50 / 0,30	15630 / 7900	58 / 43	55 / 40	106
HTMF-63-4T-3 IE3	1450	7,86	4,52		2,20	18045	59	56	108
HTMF-63-4/8T-3	1430 / 705		4,80 / 1,85		2,20 / 0,45	18045 / 8900	59 / 44	56 / 41	112
HTMF-63-6T-0.75	930	2,90	1,75		0,55	10449	48	46	95
HTMF-63-6T-1 IE3	935	3,36	1,93		0,75	11355	49	47	95
HTMF-71-4T-2 IE3	1435	5,89	3,38		1,50	16370	61	58	109
HTMF-71-4/8T-2	1430 / 725		3,40 / 1,65		1,50 / 0,30	16370 / 8270	61 / 46	58 / 43	119
HTMF-71-4T-3 IE3	1450	7,86	4,52		2,20	18490	63	60	122
HTMF-71-4/8T-3	1430 / 705		4,80 / 1,85		2,20 / 0,45	18490 / 9120	63 / 48	60 / 45	125
HTMF-71-4T-4 IE3	1455	11,01	6,33		3,00	22685	64	61	133
HTMF-71-4/8T-4	1420 / 710		6,45 / 2,28		3,00 / 0,60	22685 / 11300	64 / 49	61 / 46	135
HTMF-71-6T-1 IE3	935	3,36	1,93		0,75	13410	50	48	109
HTMF-71-6T-1.5 IE3	930	4,73	2,72		1,10	16340	51	49	116
HTMF-80-4T-4 IE3	1455	11,01	6,33		3,00	27750	65	62	163
HTMF-80-4/8T-4	1420 / 710		6,45 / 2,28		3,00 / 0,60	27750 / 13820	65 / 50	62 / 47	165
HTMF-80-4T-5.5 IE3	1445		7,95	4,61	4,00	30330	66	63	163
HTMF-80-4/8T-5.5	1450 / 715		7,88 / 2,87		3,80 / 1,00	30330 / 14950	66 / 51	63 / 48	195
HTMF-80-6T-1.5 IE3	930	4,73	2,72		1,10	19435	54	52	181
HTMF-80-6T-2 IE3	950	6,25	3,62		1,50	22165	55	53	185
HTMF-80-6T-3 IE3	960	9,78	5,62		2,20	24890	56	54	191
HTMF-80-8T-1	710	5,06	2,92		0,75	16375	53	52	151
HTMF-90-4T-5.5 IE3	1445		7,95	4,61	4,00	35200	71	68	208
HTMF-90-4/8T-5.5	1450 / 715		7,88 / 2,87		3,80 / 1,00	35200 / 17360	71 / 56	68 / 53	238
HTMF-90-4T-7.5 IE3	1455		10,40	6,04	5,50	38535	73	70	240
HTMF-90-4/8T-7.5	1450 / 720		11,40 / 3,86		5,50 / 1,10	38535 / 19130	73 / 58	70 / 55	243
HTMF-90-4T-10 IE3	1460		14,20	8,17	7,50	41410	74	71	244
HTMF-90-4/8T-10	1450 / 720		15,10 / 5,16		7,50 / 1,50	41410 / 20560	74 / 59	71 / 56	243
HTMF-90-6T-3 IE3	960	9,78	5,62		2,20	29290	60	58	205
HTMF-90-6/12T-3	900 / 455		5,62 / 3,32		2,20 / 0,55	29290 / 14800	60 / 45	58 / 43	245
HTMF-90-6T-4 IE3	970	12,80	6,36		3,00	32040	61	59	235
HTMF-90-6/12T-4	900 / 450		7,37 / 3,53		2,80 / 0,70	32040 / 16020	61 / 46	59 / 44	245
HTMF-90-8T-1	710	5,06	2,92		0,75	17060	53	52	196
HTMF-90-8T-2	700	7,32	4,21		1,50	19635	55	54	208
HTMF-100-4T-7.5 IE3	1455		10,40	6,04	5,50	41060	76	73	265
HTMF-100-4/8T-7.5	1450 / 720		11,40 / 3,86		5,50 / 1,10	41060 / 20390	76 / 61	73 / 58	269
HTMF-100-4T-10 IE3	1460		14,20	8,17	7,50	47645	77	74	269
HTMF-100-4/8T-10	1450 / 720		15,10 / 5,16		7,50 / 1,50	44590 / 22140	76 / 61	73 / 58	269
HTMF-100-4T-15 IE3	1460		20,70	11,99	11,00	51375	78	75	332
HTMF-100-4/8T-14	1460 / 725		20,70 / 7,19		11,00 / 3,00	48400 / 24000	77 / 62	74 / 59	301
HTMF-100-6T-3 IE3	960	9,78	5,62		2,20	32600	66	64	231
HTMF-100-6/12T-3	900 / 455		5,62 / 3,32		2,20 / 0,55	32600 / 16470	66 / 51	64 / 49	271
HTMF-100-6T-4 IE3	970	12,80	6,36		3,00	35500	67	65	260
HTMF-100-6/12T-4	900 / 450		7,37 / 3,53		2,80 / 0,70	35500 / 17750	67 / 52	65 / 50	271
HTMF-100-6T-5.5 IE3	970		8,37	4,82	4,00	40035	68	66	277
HTMF-100-6/12T-5.5	900 / 445		9,54 / 4,27		3,80 / 1,00	40035 / 19710	68 / 53	66 / 51	289
HTMF-100-8T-3	705	9,30	5,35		2,20	26600	61	60	260
HTMF-100-8T-4	705	12,50	7,21		3,00	28900	62	61	270

Características técnicas

Modelo	Velocidad (r/min)	Intensidad máxima admisible (A)			Potencia instalada (kW)	Caudal máximo (m³/h)	Nivel presión sonora ¹ dB (A)		Peso aprox. (Kg)
		230V	400V	690V			Aspiración	Descarga	
HTMF-THT-125-4T/6-15 IE3	1460		20,70	11,99	11,00	66810	69	66	388
HTMF-THT-125-4T/6-20 IE3	1460		27,80	16,03	15,00	72900	69	66	410
HTMF-THT-125-4T/9-20 IE3	1460		27,80	16,03	15,00	76320	68	64	425
HTMF-THT-125-6T/6-5.5 IE3	970		8,37	4,82	4,00	47770	56	54	347
HTMF-THT-125-6T/6-7.5 IE3	970		12,30	7,07	5,50	55600	56	54	384
HTMF-THT-125-6T/6-10 IE3	970		15,20	8,83	7,50	66180	58	56	393
HTMF-THT-125-6T/6-15 IE3	970		22,50	13,07	11,00	76380	60	58	415
HTMF-THT-125-6T/9-7.5 IE3	970		12,30	7,07	5,50	50000	57	55	399
HTMF-THT-125-6T/9-10 IE3	970		15,20	8,83	7,50	59340	57	55	408
HTMF-THT-125-6T/9-15 IE3	970		22,50	13,07	11,00	71890	60	58	430
HTMF-THT-125-6T/9-20 IE3	970		29,00	16,78	15,00	83660	63	61	475
HTMF-THT-125-8T/6-4	705	12,50	7,21		3,00	47510	48	47	384
HTMF-THT-125-8T/6-5.5	720		9,84	5,70	4,00	52780	50	49	404
HTMF-THT-125-8T/6-7.5	720		13,17	7,59	5,50	60410	52	51	416
HTMF-THT-125-8T/6-10	720		17,40	10,10	7,50	66030	53	52	424
HTMF-THT-125-8T/9-5.5	720		9,84	5,70	4,00	51340	50	49	419
HTMF-THT-125-8T/9-7.5	720		13,17	7,59	5,50	54490	53	52	431
HTMF-THT-125-8T/9-10	720		17,40	10,10	7,50	65670	55	54	439
HTMF-THT-125-8T/9-15	730		23,30	13,50	11,00	73880	56	55	472

¹ Los valores de los niveles sonoros, son presiones en dB(A) medidos a 10 metros, en campo libre.



Erp. (Energy Related Products)

Información de la Directiva 2009/125/EC descargable desde la web de SODECA o programa de selección QuickFan.

Características acústicas

Espectro de potencia sonora Lw(A) en dB(A) por banda de frecuencia en Hz

Valores tomados a la aspiración con caudal máximo

	63	125	250	500	1000	2000	4000	8000
56-4-1	46	67	74	79	82	78	71	60
56-4-1.5	47	68	75	80	83	79	72	61
56-8-1.5 (2V)	31	52	59	64	67	63	56	45
56-6-0.75	35	56	63	68	71	67	60	49
63-4-1.5	49	70	77	82	85	81	74	63
63-8-1.5 (2V)	33	54	61	66	69	65	58	47
63-4-2	50	71	78	83	86	82	75	64
63-8-2 (2V)	35	56	63	68	71	67	60	49
63-4-3	51	72	79	84	87	83	76	65
63-8-3 (2V)	36	57	64	69	72	68	61	50
63-6-0.75	40	61	68	73	76	72	65	54
63-6-1	41	62	69	74	77	73	66	55
71-4-2	53	74	81	86	89	85	78	67
71-8-2 (2V)	38	59	66	71	74	70	63	52
71-4-3	55	76	83	88	91	87	80	69
71-8-3 (2V)	40	61	68	73	76	72	65	54
71-4-4	56	77	84	89	92	88	81	70
71-8-4 (2V)	41	62	69	74	77	73	66	55
71-6-1	42	63	70	75	78	74	67	56
71-6-1.5	43	64	71	76	79	75	68	57
80-4-4	57	78	85	90	93	89	82	71
80-8-4 (2V)	42	63	70	75	78	74	67	56
80-4-5.5	58	79	86	91	94	90	83	72
80-8-5.5 (2V)	43	64	71	76	79	75	68	57
80-6-1.5	46	67	74	79	82	78	71	60
80-6-2	47	68	75	80	83	79	72	61

Valores tomados a la descarga con caudal máximo

	63	125	250	500	1000	2000	4000	8000
56-4-1	43	64	71	76	79	75	68	57
56-4-1.5	44	65	72	77	80	76	69	58
56-8-1.5 (2V)	28	49	56	61	64	60	53	42
56-6-0.75	33	54	61	66	69	65	58	47
63-4-1.5	46	67	74	79	82	78	71	60
63-8-1.5 (2V)	30	51	58	63	66	62	55	44
63-4-2	47	68	75	80	83	79	72	61
63-8-2 (2V)	32	53	60	65	68	64	57	46
63-4-3	48	69	76	81	84	80	73	62
63-8-3 (2V)	33	54	61	66	69	65	58	47
63-6-0.75	38	59	66	71	74	70	63	52
63-6-1	39	60	67	72	75	71	64	53
71-4-2	50	71	78	83	86	82	75	64
71-8-2 (2V)	35	56	63	68	71	67	60	49
71-4-3	52	73	80	85	88	84	77	66
71-8-3 (2V)	37	58	65	70	73	69	62	51
71-4-4	53	74	81	86	89	85	78	67
71-8-4 (2V)	38	59	66	71	74	70	63	52
71-6-1	40	61	68	73	76	72	65	54
71-6-1.5	41	62	69	74	77	73	66	55
80-4-4	54	75	82	87	90	86	79	68
80-8-4 (2V)	39	60	67	72	75	71	64	53
80-4-5.5	55	76	83	88	91	87	80	69
80-8-5.5 (2V)	40	61	68	73	76	72	65	54
80-6-1.5	44	65	72	77	80	76	69	58
80-6-2	45	66	73	78	81	77	70	59

Características acústicas

Espectro de potencia sonora Lw(A) en dB(A) por banda de frecuencia en Hz

Valores tomados a la aspiración con caudal máximo

	63	125	250	500	1000	2000	4000	8000
80-6-3	48	69	76	81	84	80	73	62
80-8-1	45	66	73	78	81	77	70	59
90-4-5.5	63	84	91	96	99	95	88	77
90-8-5.5 (2V)	48	69	76	81	84	80	73	62
90-4-7.5	65	86	93	98	101	97	90	79
90-8-7.5 (2V)	50	71	78	83	86	82	75	64
90-4-10	66	87	94	99	102	98	91	80
90-8-10 (2V)	51	72	79	84	87	83	76	65
90-6-3	52	73	80	85	88	84	77	66
90-12-3 (2V)	37	58	65	70	73	69	62	51
90-6-4	53	74	81	86	89	85	78	67
90-12-4 (2V)	38	59	66	71	74	70	63	52
90-8-1	45	66	73	78	81	77	70	59
90-8-2	47	68	75	80	83	79	72	61
100-4-7.5	68	89	96	101	104	100	93	82
100-8-7.5 (2V)	53	74	81	86	89	85	78	67
100-4-10	68	89	96	101	104	100	93	82
100-8-10 (2V)	53	74	81	86	89	85	78	67
100-4-14	69	90	97	102	105	101	94	83
100-8-14 (2V)	54	75	82	87	90	86	79	68
100-4-15	70	91	98	103	106	102	95	84
100-6-3	58	79	86	91	94	90	83	72
100-12-3 (2V)	43	64	71	76	79	75	68	57
100-6-4	59	80	87	92	95	91	84	73
100-12-4 (2V)	44	65	72	77	80	76	69	58
100-6-5.5	60	81	88	93	96	92	85	74
100-12-5.5 (2V)	45	66	73	78	81	77	70	59
100-8-3	53	74	81	86	89	85	78	67
100-8-4	54	75	82	87	90	86	79	68
125-4/6-15	63	72	87	94	97	91	85	81
125-4/6-20	63	72	87	94	97	91	85	81
125-4/9-20	62	71	87	93	95	89	84	80
125-6/6-5.5	56	66	78	81	83	79	68	64
125-6/6-7.5	56	66	78	81	83	79	68	64
125-6/6-10	58	68	80	83	85	81	70	66
125-6/6-15	60	70	82	85	87	83	72	68
125-6/9-7.5	54	65	79	83	83	81	70	66
125-6/9-10	54	65	79	83	83	81	70	66
125-6/9-15	57	68	82	86	86	84	73	69
125-6/9-20	60	71	85	89	89	87	76	72
125-8/6-4	50	59	70	75	75	69	58	54
125-8/6-5.5	52	61	72	77	77	71	60	56
125-8/6-7.5	54	63	74	79	79	73	62	58
125-8/6-10	55	64	75	80	80	74	63	59
125-8/9-5.5	49	61	70	76	78	72	61	57
125-8/9-7.5	52	64	73	79	81	75	64	60
125-8/9-10	54	66	75	81	83	77	66	62
125-8/9-15	55	67	76	82	84	78	67	63

Valores tomados a la descarga con caudal máximo

	63	125	250	500	1000	2000	4000	8000
80-6-3	46	67	74	79	82	78	71	60
80-8-1	44	65	72	77	80	76	69	58
90-4-5.5	60	81	88	93	96	92	85	74
90-8-5.5 (2V)	45	66	73	78	81	77	70	59
90-4-7.5	62	83	90	95	98	94	87	76
90-8-7.5 (2V)	47	68	75	80	83	79	72	61
90-4-10	63	84	91	96	99	95	88	77
90-8-10 (2V)	48	69	76	81	84	80	73	62
90-6-3	50	71	78	83	86	82	75	64
90-12-3 (2V)	35	56	63	68	71	67	60	49
90-6-4	51	72	79	84	87	83	76	65
90-12-4 (2V)	36	57	64	69	72	68	61	50
90-8-1	44	65	72	77	80	76	69	58
90-8-2	46	67	74	79	82	78	71	60
100-4-7.5	65	86	93	98	101	97	90	79
100-8-7.5 (2V)	50	71	78	83	86	82	75	64
100-4-10	65	86	93	98	101	97	90	79
100-8-10 (2V)	50	71	78	83	86	82	75	64
100-4-14	66	87	94	99	102	98	91	80
100-8-14 (2V)	51	72	79	84	87	83	76	65
100-4-15	67	88	95	100	103	99	92	81
100-6-3	56	77	84	89	92	88	81	70
100-12-3 (2V)	41	62	69	74	77	73	66	55
100-6-4	57	78	85	90	93	89	82	71
100-12-4 (2V)	42	63	70	75	78	74	67	56
100-6-5.5	58	79	86	91	94	90	83	72
100-12-5.5 (2V)	43	64	71	76	79	75	68	57
100-8-3	52	73	80	85	88	84	77	66
100-8-4	53	74	81	86	89	85	78	67
125-4/6-15	60	69	84	91	94	88	82	78
125-4/6-20	60	69	84	91	94	88	82	78
125-4/9-20	59	68	84	90	92	86	81	77
125-6/6-5.5	54	64	76	79	81	77	66	62
125-6/6-7.5	54	64	76	79	81	77	66	62
125-6/6-10	56	66	78	81	83	79	68	64
125-6/6-15	58	68	80	83	85	81	70	66
125-6/9-7.5	52	63	77	81	81	79	68	64
125-6/9-10	52	63	77	81	81	79	68	64
125-6/9-15	55	66	80	84	84	82	71	67
125-6/9-20	58	69	83	87	87	85	74	70
125-8/6-4	49	58	69	74	74	68	57	53
125-8/6-5.5	51	60	71	76	76	70	59	55
125-8/6-7.5	53	62	73	78	78	72	61	57
125-8/6-10	54	63	74	79	79	73	62	58
125-8/9-5.5	48	60	69	75	77	71	60	56
125-8/9-7.5	51	63	72	78	80	74	63	59
125-8/9-10	53	65	74	80	82	76	65	61
125-8/9-15	54	66	75	81	83	77	66	62

Dimensiones mm

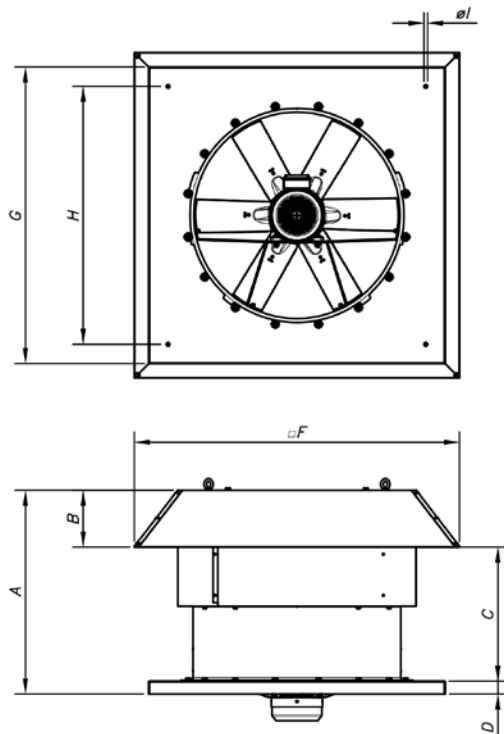

	A	B	C	D	F	G	H	ØI
HTMF-56	650	185	425	40	960	900	750	14
HTMF-63	680	215	425	40	1092	1000	850	14
HTMF-71	759	195	524	40	1120	1000	850	14
HTMF-80	790	216	524	50	1252	1150	1000	14
HTMF-90	920	232	638	50	1380	1150	1000	14
HTMF-100	1055	252	753	50	1527	1250	1100	14
HTMF-125	1170	311	809	50	1803	1425	1275	17

Curvas características

Q= Caudal en m³/h, m³/s y cfm

Pe= Presión estática en mmH₂O, Pa e inwg

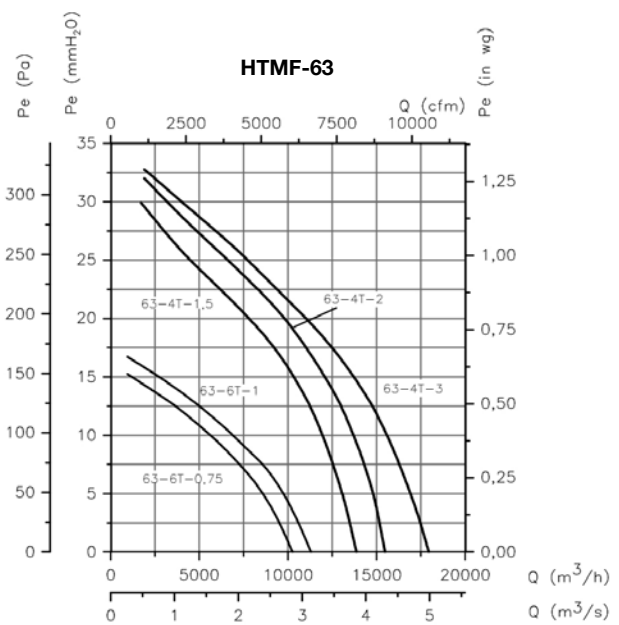
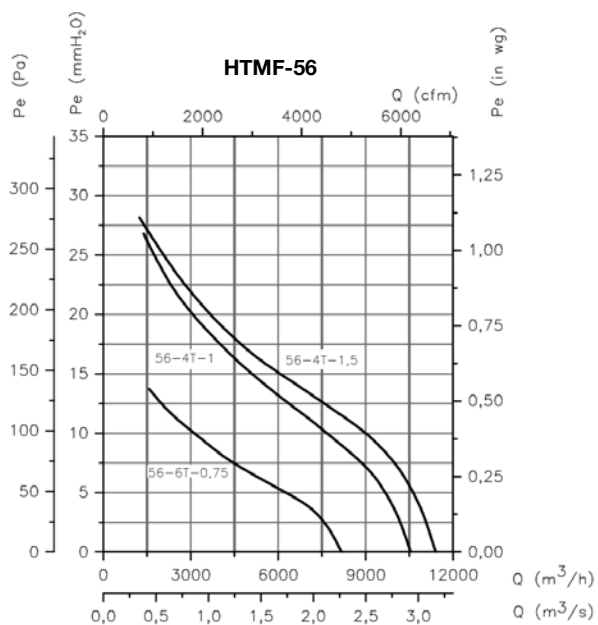

Curvas características

Q= Caudal en m³/h, m³/s y cfm

Pe= Presión estática en mmH₂O, Pa e inwg

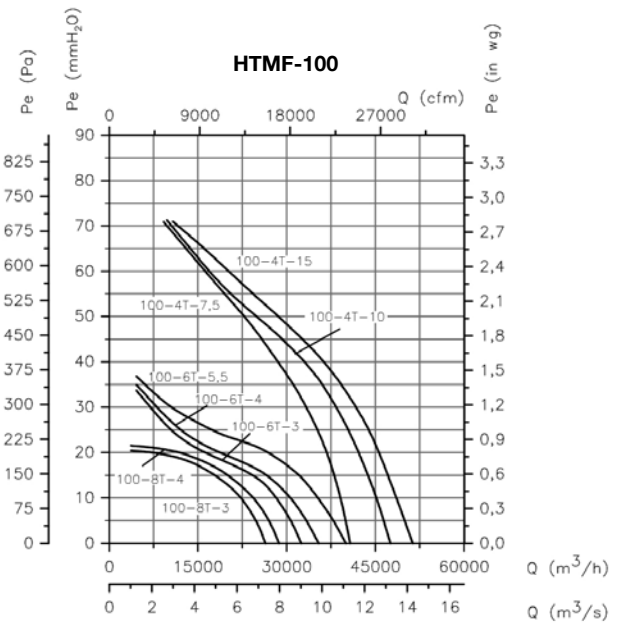
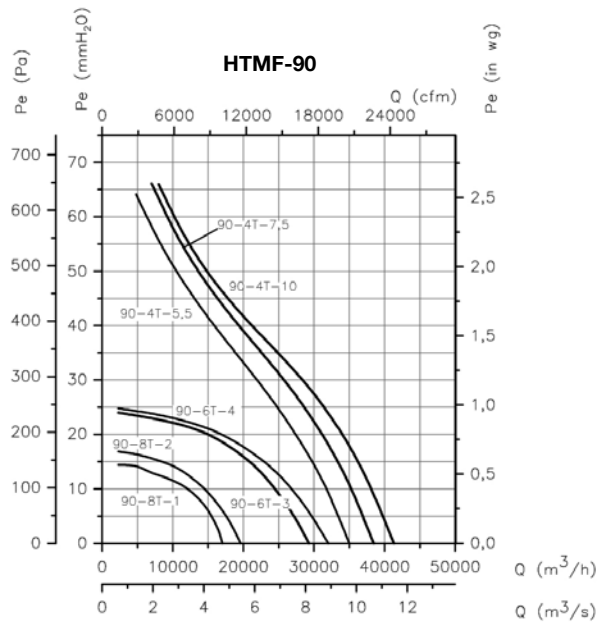
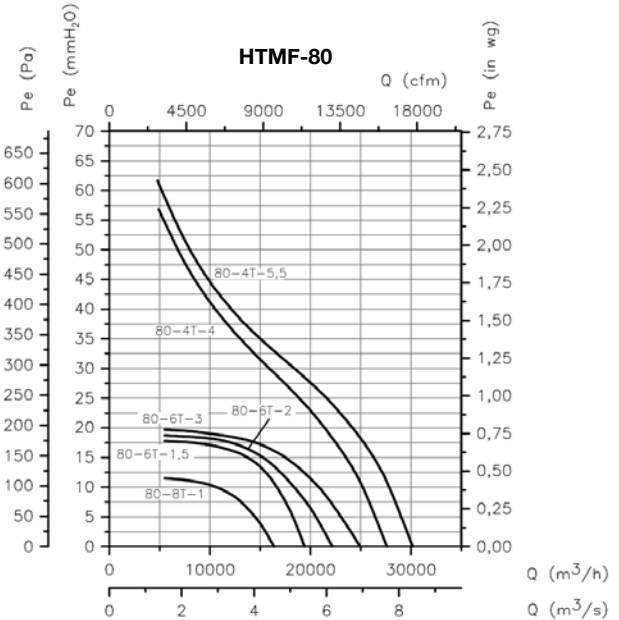
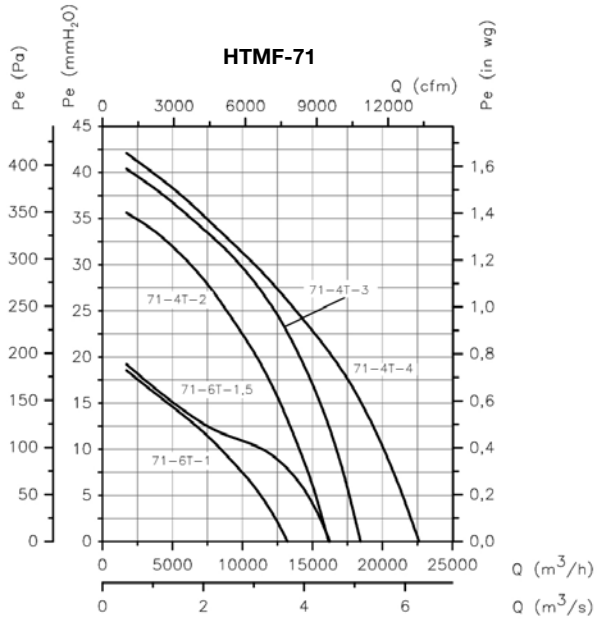

Curvas características

Q= Caudal en m³/h, m³/s y cfm

Pe= Presión estática en mmH₂O, Pa e inwg

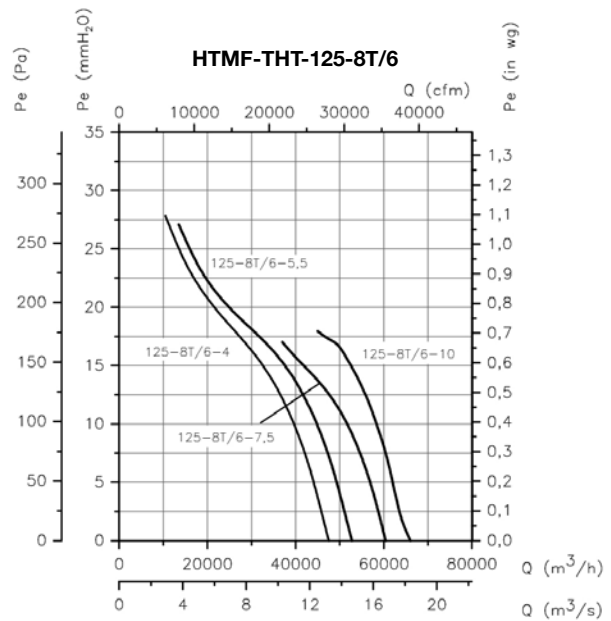
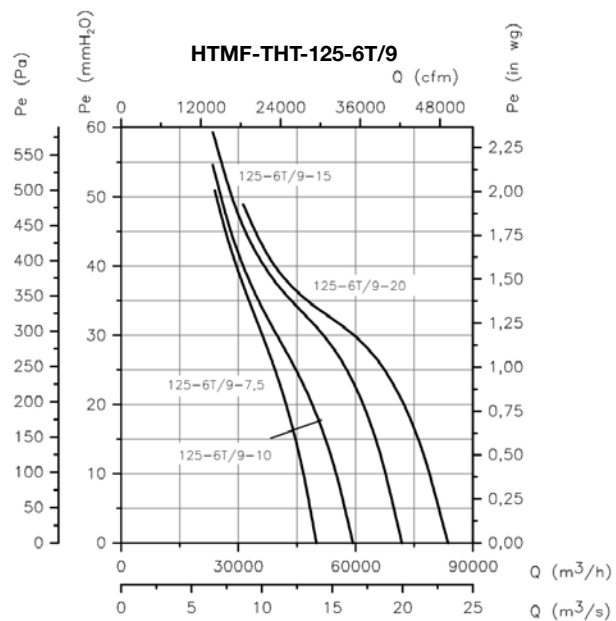
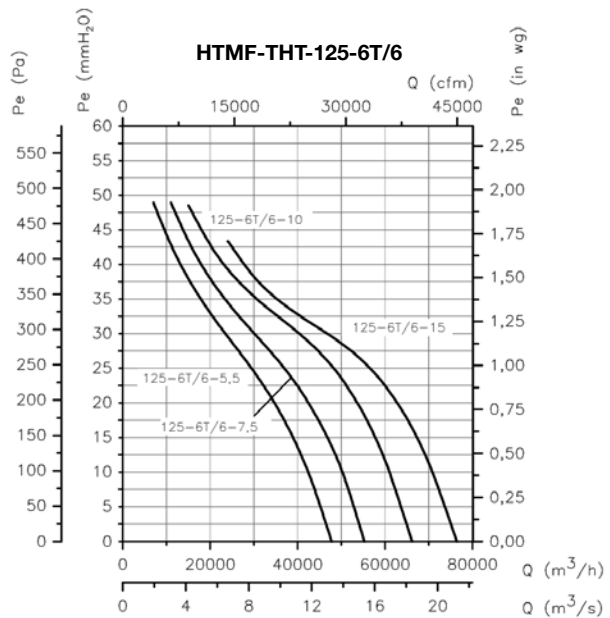
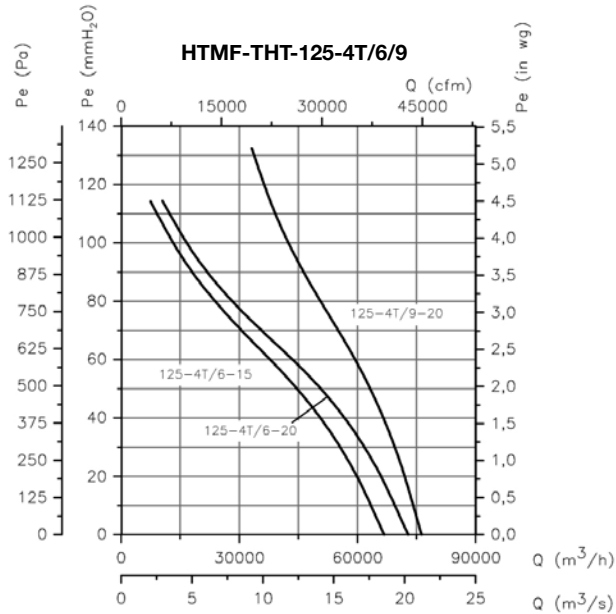

Curvas características

Q= Caudal en m³/h, m³/s y cfm

Pe= Presión estática en mmH₂O, Pa e inwg

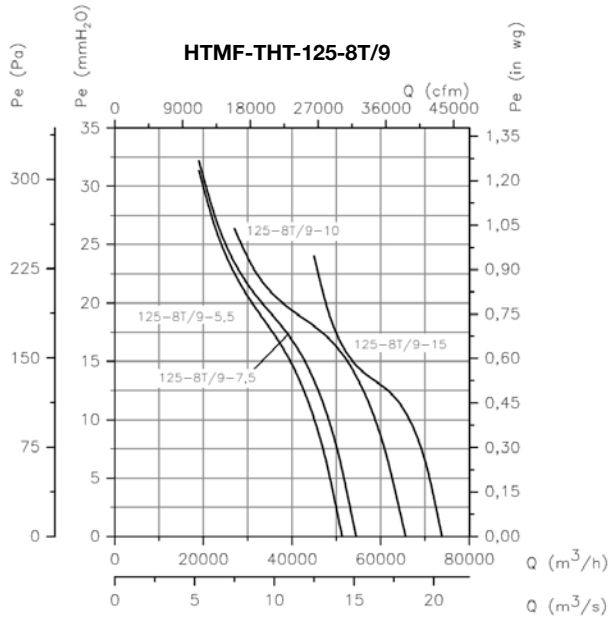

Variación de la presión sonora según distancia

El nivel sonoro puede variar dependiendo de la estructura de la cubierta o tejado.

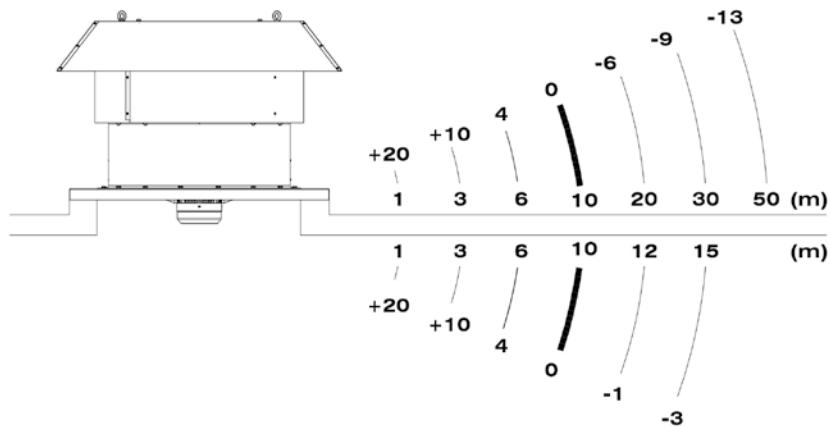

Accesorios



INT



IAT



CABLE BOX



C2V



VSD3/A-RFT
- VSD1/A-RFM



CENTRAL CO



AET

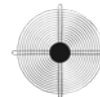

RT

THT/ROOF

Extractores helicoidales de cubierta con salida de aire vertical 400 °C/2h y 300 °C/2h



Extractores helicoidales de cubierta con salida de aire vertical, para trabajar inmersos en zonas de riesgo de incendios, diseñados para evacuación de humos en naves industriales o similares.

Ventilador:

- Base soporte en chapa de acero galvanizada y tratamiento anticorrosivo.
- Hélice orientable en fundición de aluminio.
- Rejilla de protección contra contactos según norma UNE-EN ISO 12499.
- Compuerta antiretorno en chapa de aluminio para evitar la entrada de agua cuando el ventilador no está en funcionamiento.
- Homologación según norma EN 12101-3, con certificaciones n°: 0370-CPR-3080 (F400) y 0370-CPR-3056 (F300).
- Dirección aire motor-hélice.

Motor:

- Motores con eficiencia IE3 para potencias iguales o superiores a 0,75 kW, excepto monofásicos, 2 velocidades y 8 polos.

- Motores clase H para uso continuo S1 y uso emergencia S2. Con rodamientos a bolas y protección IP55.
- Trifásico 230/400 V 50 Hz (hasta 3 kW) y 400/690 V 50 Hz (potencias superiores a 3 kW).
- Temperatura máxima del aire a transportar: Servicio S1 -25 °C +40 °C en continuo, apto también para climas cálidos con temperaturas hasta 50 °C. Servicio S2 300 °C/2h, 400 °C/2h.

Acabado:

- Anticorrosivo en resina de poliéster polimerizada a 190 °C, previo desengrase con tratamiento nanotecnológico libre de fosfatos.

Bajo demanda:

- Extractores con motor de 2 velocidades.
- Ventiladores de 2 y 8 polos según diámetro.

Código de pedido

De tamaño 40 a tamaño 100

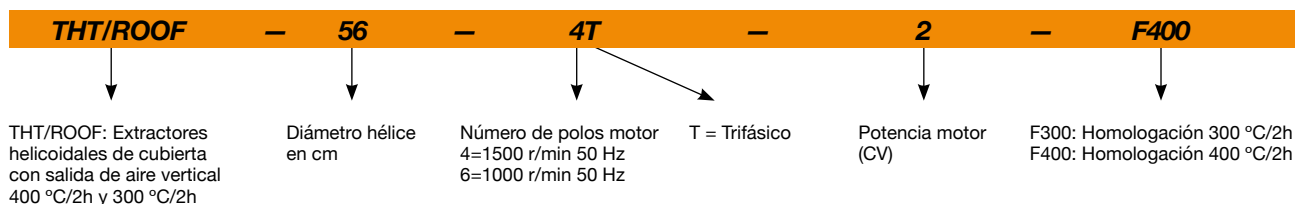

Tamaño 125

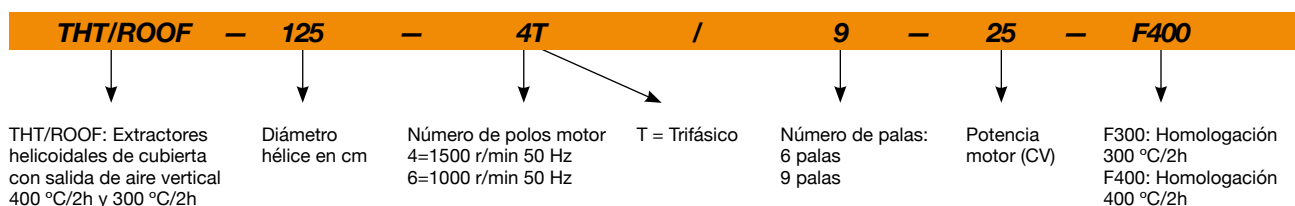

Características técnicas

Modelo	Velocidad (r/min)	Intensidad máxima admisible (A)			Potencia instalada (kW)	Ángulo inclinación palas (°)	Caudal máximo (m³/h)	Nivel presión sonora ¹ dB (A)		Peso aprox. (Kg)
		230V	400V	690V				Aspiración	Descarga	
THT/ROOF-40-4T-0.75	1420	2,84	1,64		0,55	32	4800	45	44	39
THT/ROOF-40-6T-0.75	930	2,90	1,75		0,55	32	3150	36	35	44
THT/ROOF-45-4T-0.75	1420	2,84	1,64		0,55	36	7450	48	47	42
THT/ROOF-45-6T-0.75	930	2,90	1,75		0,55	30	4450	38	37	47
THT/ROOF-50-4T-1 IE3	1410	3,08	1,79		0,75	28	9730	50	49	51
THT/ROOF-50-6T-0.75	930	2,90	1,75		0,55	32	7000	42	41	54
THT/ROOF-56-4T-1 IE3	1410	3,08	1,79		0,75	22	11250	53	52	58
THT/ROOF-56-4T-1.5 IE3	1430	4,10	2,37		1,10	30	13600	53	52	58
THT/ROOF-56-4T-2 IE3	1435	5,89	3,38		1,50	36	15030	54	53	61
THT/ROOF-56-6T-0.75	930	2,90	1,75		0,55	38	10140	44	43	57
THT/ROOF-63-4T-1.5 IE3	1430	4,10	2,37		1,10	20	17800	56	55	67
THT/ROOF-63-4T-2 IE3	1435	5,89	3,38		1,50	24	19280	56	55	71
THT/ROOF-63-4T-3 IE3	1450	7,86	4,52		2,20	32	22150	58	57	76
THT/ROOF-63-4T-4 IE3	1455	11,01	6,33		3,00	38	24240	59	58	85
THT/ROOF-63-6T-0.75	930	2,90	1,75		0,55	28	13590	47	46	67
THT/ROOF-63-6T-1 IE3	935	3,36	1,93		0,75	38	15890	48	47	70
THT/ROOF-71-4T-2 IE3	1435	5,89	3,38		1,50	14	20900	60	59	78
THT/ROOF-71-4T-3 IE3	1450	7,86	4,52		2,20	22	25100	60	59	83
THT/ROOF-71-4T-4 IE3	1455	11,01	6,33		3,00	28	27480	60	59	92
THT/ROOF-71-6T-0.75	930	2,90	1,75		0,55	20	16100	50	49	74
THT/ROOF-71-6T-1 IE3	935	3,36	1,93		0,75	26	17300	50	49	77
THT/ROOF-71-6T-1.5 IE3	930	4,73	2,72		1,10	34	19930	51	50	83
THT/ROOF-80-4T-4 IE3	1455	11,01	6,33		3,00	16	30250	64	63	114
THT/ROOF-80-4T-5.5 IE3	1445		7,95	4,61	4,00	18	32750	63	62	121
THT/ROOF-80-6T-1.5 IE3	930	4,73	2,72		1,10	18	21450	53	52	105
THT/ROOF-80-6T-2 IE3	950	6,25	3,62		1,50	26	25950	54	53	114
THT/ROOF-80-6T-3 IE3	960	9,78	5,62		2,20	32	29930	55	54	120
THT/ROOF-90-4T-5.5 IE3	1445		7,95	4,61	4,00	12	38890	68	67	134
THT/ROOF-90-4T-7.5 IE3	1455		10,40	6,04	5,50	18	46140	67	66	161
THT/ROOF-90-4T-10 IE3	1460		14,20	8,17	7,50	22	50140	66	65	172
THT/ROOF-90-6T-2 IE3	950	6,25	3,62		1,50	16	28780	56	55	127
THT/ROOF-90-6T-3 IE3	960	9,78	5,62		2,20	24	34000	56	55	134
THT/ROOF-90-6T-4 IE3	970	12,80	6,36		3,00	30	38900	59	58	159
THT/ROOF-100-4T-7.5 IE3	1455		10,40	6,04	5,50	10	46850	72	71	172
THT/ROOF-100-4T-10 IE3	1460		14,20	8,17	7,50	16	57400	69	68	183
THT/ROOF-100-4T-15 IE3	1460		20,70	11,99	11,00	22	66300	69	68	236
THT/ROOF-100-4T-20 IE3	1460		27,80	16,03	15,00	28	76150	70	69	251
THT/ROOF-100-6T-3 IE3	960	9,78	5,62		2,20	16	37600	60	59	146
THT/ROOF-100-6T-4 IE3	970	12,80	6,36		3,00	20	41150	59	58	171
THT/ROOF-100-6T-5.5 IE3	970		8,37	4,82	4,00	26	47780	60	59	183
THT/ROOF-125-4T/6-25 IE3	1475		35,40	20,39	18,50	14	92550	70	69	413
THT/ROOF-125-4T/6-30 IE3	1475		42,20	24,44	22,00	16	98830	69	68	427
THT/ROOF-125-4T/6-40 IE3	1470		53,30	31,02	30,00	22	117450	69	68	507
THT/ROOF-125-4T/6-50 IE3	1480		66,80	38,70	37,00	26	131050	69	68	543
THT/ROOF-125-4T/9-25 IE3	1475		35,40	20,39	18,50	10	79650	77	76	422
THT/ROOF-125-4T/9-30 IE3	1475		42,20	24,44	22,00	12	88290	76	75	436
THT/ROOF-125-4T/9-40 IE3	1470		53,30	31,02	30,00	16	104040	75	74	516
THT/ROOF-125-4T/9-50 IE3	1480		66,80	38,70	37,00	20	118400	75	74	552
THT/ROOF-125-6T/6-5.5 IE3	970		8,37	4,82	4,00	10	51500	62	61	288
THT/ROOF-125-6T/6-7.5 IE3	970		12,30	7,07	5,50	14	60640	60	59	295
THT/ROOF-125-6T/6-10 IE3	970		15,20	8,83	7,50	20	72650	59	58	325
THT/ROOF-125-6T/6-15 IE3	970		22,50	13,07	11,00	26	85850	60	59	355
THT/ROOF-125-6T/6-20 IE3	970		29,00	16,78	15,00	30	92850	61	60	413
THT/ROOF-125-6T/9-10 IE3	970		15,20	8,83	7,50	14	63490	67	66	334
THT/ROOF-125-6T/9-15 IE3	970		22,50	13,07	11,00	20	77550	65	64	364
THT/ROOF-125-6T/9-20 IE3	970		29,00	16,78	15,00	26	92950	65	64	422

¹ Los valores de los niveles sonoros, son presiones en dB(A) medidos a 10 metros, en campo libre.



Erp. (Energy Related Products)

Información de la Directiva 2009/125/EC descargable desde la web de SODECA o programa de selección QuickFan.

Características acústicas

Espectro de potencia sonora Lw(A) en dB(A) por banda de frecuencia en Hz

Valores tomados a la aspiración con caudal máximo

	63	125	250	500	1000	2000	4000	8000
40-4-0.75	37	53	63	70	71	68	67	68
40-6-0.75	28	44	54	61	62	59	58	59
45-4-0.75	47	59	67	73	73	73	68	60
45-6-0.75	37	49	57	63	63	63	58	50
50-4-1	49	61	69	75	75	75	70	62
50-6-0.75	41	53	61	67	67	67	62	54
56-4-1	51	63	72	78	78	78	72	64
56-4-1.5	51	63	72	78	78	78	72	64
56-4-2	52	64	73	79	79	79	73	65
56-6-0.75	45	55	65	69	70	68	61	53
63-4-1.5	47	63	75	81	83	80	73	65
63-4-2	54	66	75	81	81	81	75	67
63-4-3	56	68	77	83	83	83	77	69
63-4-4	57	69	78	84	84	84	78	70
63-6-0.75	48	58	68	72	73	71	64	56
63-6-1	49	59	69	73	74	72	65	57
71-4-2	56	72	79	85	85	85	81	73
71-4-3	56	72	79	85	85	85	81	73
71-4-4	63	75	79	85	85	86	83	75
71-6-0.75	46	53	73	76	76	71	63	55
71-6-1	46	64	73	76	76	71	64	55
71-6-1.5	47	65	74	77	77	72	65	56
80-4-4	54	70	83	90	90	87	81	73
80-4-5.5	53	69	82	89	89	86	80	72
80-6-1.5	53	68	75	78	79	76	70	62
80-6-2	59	69	75	79	80	78	73	65
80-6-3	60	70	76	80	81	79	74	66
90-4-5.5	60	76	87	93	94	92	87	79
90-4-7.5	59	75	86	92	93	91	86	78
90-4-10	58	74	85	91	92	90	85	77
90-6-2	52	67	78	82	82	78	71	63
90-6-3	52	67	78	82	82	78	71	63
90-6-4	60	70	80	85	85	82	76	68
100-4-7.5	67	83	90	97	98	96	92	84
100-4-10	64	80	87	94	95	93	89	81
100-4-15	71	83	87	93	94	94	91	83
100-4-20	72	84	88	94	95	95	92	84
100-6-3	57	72	82	85	86	83	75	67
100-6-4	56	71	81	84	85	82	74	66
100-6-5.5	57	72	82	85	86	83	75	67
125-4/6-25	65	81	88	95	96	94	90	82
125-4/6-30	64	80	87	94	95	93	89	81
125-4/6-40	71	83	87	93	94	94	91	83
125-4/6-50	71	83	87	93	94	94	91	83
125-4/9-25	67	81	94	102	104	101	96	88
125-4/9-30	66	80	93	101	103	100	95	87
125-4/9-40	65	79	92	100	102	99	94	86
125-4/9-50	65	79	92	100	102	99	94	86
125-6/6-5.5	59	74	84	87	88	85	77	69
125-6/6-7.5	57	72	82	85	86	83	75	67
125-6/6-10	56	71	81	84	85	82	74	66
125-6/6-15	57	72	82	85	86	83	75	67
125-6/6-20	58	73	83	86	87	84	76	68
125-6/9-10	61	76	87	93	94	88	84	77
125-6/9-15	59	74	85	91	92	86	82	75
125-6/9-20	59	74	85	91	92	86	82	75

Valores tomados a la descarga con caudal máximo

	63	125	250	500	1000	2000	4000	8000
40-4-0.75	36	52	62	69	70	67	66	67
40-6-0.75	27	43	53	60	61	58	57	58
45-4-0.75	46	58	66	72	72	72	67	59
45-6-0.75	36	48	56	62	62	62	57	49
50-4-1	48	60	68	74	74	74	69	61
50-6-0.75	40	52	60	66	66	66	61	53
56-4-1	50	62	71	77	77	77	71	63
56-4-1.5	50	62	71	77	77	77	71	63
56-4-2	51	63	72	78	78	78	72	64
56-6-0.75	44	54	64	68	69	67	60	52
63-4-1.5	46	62	74	80	82	79	72	64
63-4-2	53	65	74	80	80	80	74	66
63-4-3	55	67	76	82	82	82	76	68
63-4-4	56	68	77	83	83	83	77	69
63-6-0.75	47	57	67	71	72	70	63	55
63-6-1	48	58	68	72	73	71	64	56
71-4-2	55	71	78	84	84	84	80	72
71-4-3	55	71	78	84	84	84	80	72
71-4-4	62	74	78	84	84	85	82	74
71-6-0.75	45	52	72	75	75	70	62	54
71-6-1	45	63	72	75	75	70	63	54
71-6-1.5	46	64	73	76	76	71	64	55
80-4-4	53	69	82	89	89	86	80	72
80-4-5.5	52	68	81	88	88	85	79	71
80-6-1.5	52	67	74	77	78	75	69	61
80-6-2	58	68	74	78	79	77	72	64
80-6-3	59	69	75	79	80	78	73	65
90-4-5.5	59	75	86	92	93	91	86	78
90-4-7.5	58	74	85	91	92	90	85	77
90-4-10	57	73	84	90	91	89	84	76
90-6-2	51	66	77	81	81	77	70	62
90-6-3	51	66	77	81	81	77	70	62
90-6-4	59	69	79	84	84	81	75	67
100-4-7.5	66	82	89	96	97	95	91	83
100-4-10	63	79	86	93	94	92	88	80
100-4-15	70	82	86	92	93	93	90	82
100-4-20	71	83	87	93	94	94	91	83
100-6-3	56	71	81	84	85	82	74	66
100-6-4	55	70	80	83	84	81	73	65
100-6-5.5	56	71	81	84	85	82	74	66
125-4/6-25	64	80	87	94	95	93	89	81
125-4/6-30	63	79	86	93	94	92	88	80
125-4/6-40	70	82	86	92	93	93	90	82
125-4/6-50	70	82	86	92	93	93	90	82
125-4/9-25	66	80	93	101	103	100	95	87
125-4/9-30	65	79	92	100	102	99	94	86
125-4/9-40	64	78	91	99	101	98	93	85
125-4/9-50	64	78	91	99	101	98	93	85
125-6/6-5.5	58	73	83	86	87	84	76	68
125-6/6-7.5	56	71	81	84	85	82	74	66
125-6/6-10	55	70	80	83	84	81	73	65
125-6/6-15	56	71	81	84	85	82	74	66
125-6/6-20	57	72	82	85	86	83	75	67
125-6/9-10	60	75	86	92	93	87	83	76
125-6/9-15	58	73	84	90	91	85	81	74
125-6/9-20	58	73	84	90	91	85	81	74

Dimensiones mm

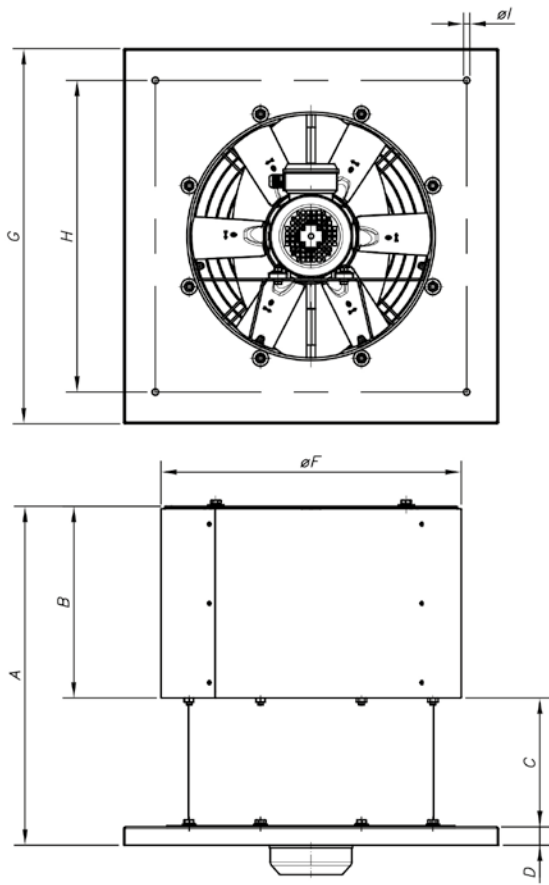

	A	B	C	D	ØF	G	H	ØI
THT/ROOF-40	628	349	244	35	519	630	530	12
THT/ROOF-45	642	363	244	35	569	710	590	12
THT/ROOF-50	679	400	244	35	626	900	750	12
THT/ROOF-56	710	426	244	40	686	900	750	14
THT/ROOF-63	747	463	244	40	753	1000	850	14
THT/ROOF-71	830	498	292	40	833	1000	850	14
THT/ROOF-80	887	545	292	50	923	1150	1000	14
THT/ROOF-90	989	601	338	50	1031	1150	1000	14
THT/ROOF-100	1136	648	438	50	1128	1250	1100	14
THT/ROOF-125	1313	775	488	50	1386	1425	1275	17

Curvas características

Ver curvas características serie: THT

Accesorios



INT



IAT



CABLE BOX



C2V



VSD3/A-RFT
- VSD1/A-RFM



CENTRAL CO



AET

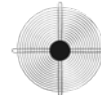

RT

CJBDT

Unidades de extracción con motor directo, para trabajar inmersos en zonas de riesgo de incendio 400 °C/2h y 300 °C/2h



Unidades de extracción centrífugas de doble aspiración con motor directo, para trabajar inmersos en zonas de riesgo de incendio 400 °C/2h. Con posibilidad de motor monofásico.

Ventilador:

- Envoltente en chapa de acero galvanizado.
- Turbina a acción en chapa de acero galvanizado.
- Caja de bornes externa.
- Amortiguadores antivibratorios.
- Homologación según norma EN 12101-3, con certificación n°: 0370-CPR-0580.

Motor:

- Motores clase H para uso continuo S1 y uso emergencia S2. Con rodamientos a bolas, protección IP55 y 1 o 2 velocidades según modelo.

- Monofásico 230 V 50 Hz y trifásico 230/400 V 50 Hz (hasta 3 kW) y 400/690 V 50 Hz (potencias superiores a 3 kW).
- Temperatura máxima del aire a transportar: Servicio S1 -20 °C +60 °C en continuo. Servicio S2 300 °C/2h, 400 °C/2h.

Acabado:

- Anticorrosivo en chapa de acero galvanizado.

Bajo demanda:

- Extractores con impulsión circular.
- Extractores con salida vertical.

Código de pedido

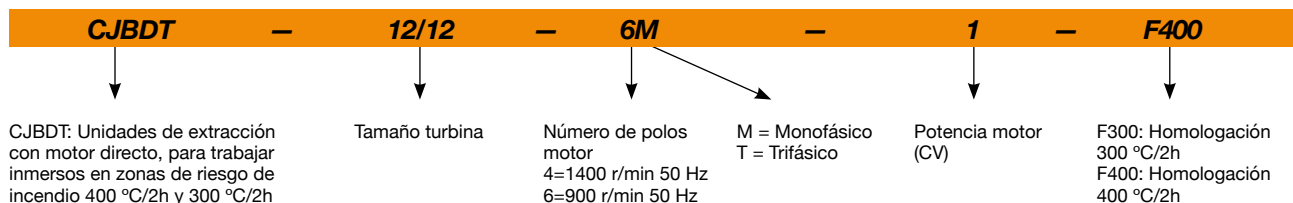

Características técnicas

Modelo	Velocidad (r/min)	Intensidad máxima admisible (A)			Potencia instalada (kW)	Caudal máximo (m³/h)	Nivel presión sonora ¹ (dB (A))	Peso aprox. (Kg)
		230V	400V	690V				
CJBDT-9/9-4T	1420	2,90	1,70		0,55	3000	57	44
CJBDT-9/9-4M	1410	4,10			0,55	3000	57	44
CJBDT-10/10-4T	1420	2,90	1,70		0,55	3450	60	49
CJBDT-10/10-4M	1410	4,10			0,55	3450	60	49
CJBDT-12/12-6T-1	945	4,40	2,60		0,75	4800	57	69
CJBDT-12/12-6M-1	920	5,80			0,75	4800	57	69
CJBDT-12/12-6T-1.5	970	6,40	3,70		1,10	6200	58	71
CJBDT-12/12-6M-1.5	920	8,40			1,10	6200	58	71
CJBDT-15/15-6T	950	10,30	5,90		2,20	8250	62	110
CJBDT-18/18-6T	970		11,00	6,35	4,00	11800	64	175

¹ Nivel de presión sonora irradiada en dB(A) a 3 m de distancia.



Erp. (Energy Related Products)

Información de la Directiva 2009/125/EC descargable desde la web de SODECA o programa de selección QuickFan.

Características acústicas

Espectro de potencia sonora irradiada Lw(A) en dB(A) por banda de frecuencia en Hz

	63	125	250	500	1000	2000	4000	8000		63	125	250	500	1000	2000	4000	8000
CJBDT-9/9-4-0.75	51	66	70	69	68	65	65	55	CJBDT-12/12-6-1.5	52	67	71	70	69	66	66	56
CJBDT-10/10-4-0.75	54	69	73	72	71	68	68	58	CJBDT-15/15-6-3	63	72	74	76	71	70	64	55
CJBDT-12/12-6-1	51	66	70	69	68	65	65	55	CJBDT-18/18-6-5.5	64	74	76	78	73	72	66	57

Dimensiones mm

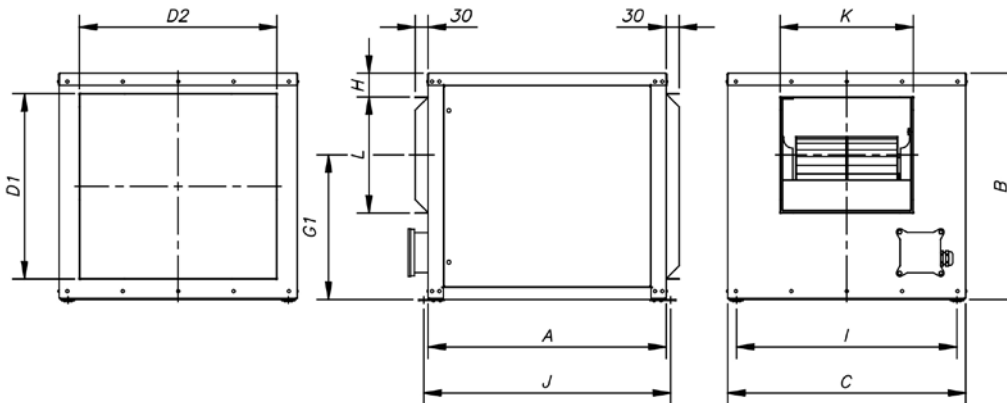

	A	B	C	D1	D2	G1	H	I	J	K	L
CJBDT-9/9	550	522	550	428	456	333,5	54,5	509	570	308	268
CJBDT-10/10	600	575	600	480	505	361,5	65,5	559	620	334	296
CJBDT-12/12	650	650	700	555	605	418	57,5	659	670	395	349
CJBDT-15/15	755	755	800	660	705	485	64	759	775	478	412
CJBDT-18/18	1000	900	1000	804	904	585	69,5	934	1041	550	491

Curvas características

Q= Caudal en m³/h, m³/s y cfm

Pe= Presión estática en mmH₂O, Pa e inwg

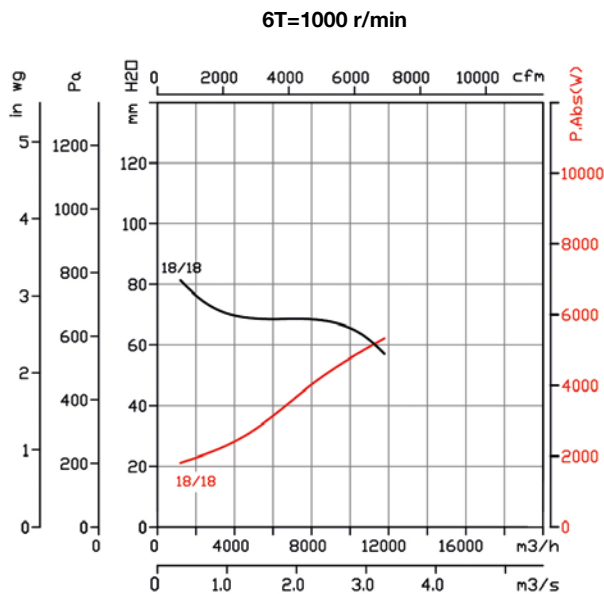
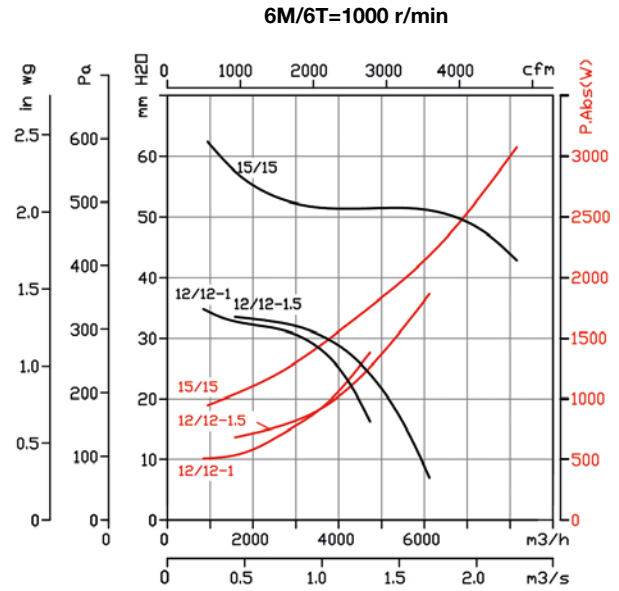
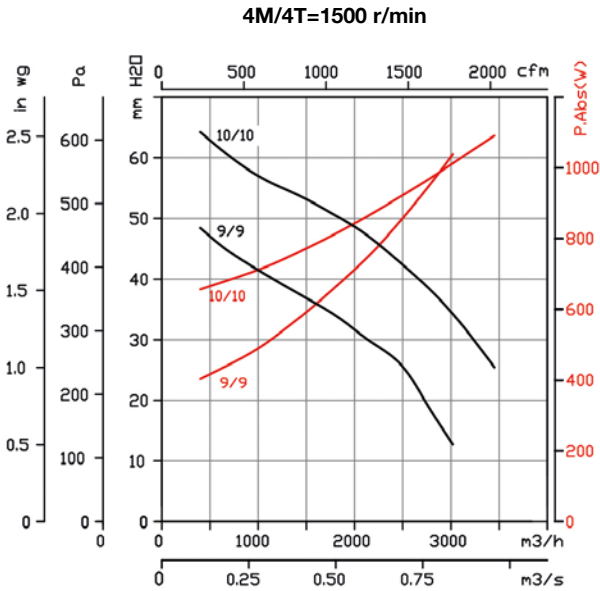

Accesorios



CBDT

Extractores centrífugos de doble aspiración, motor directo, para trabajar inmersos en zonas de riesgo de incendio 400 °C/2h y 300 °C/2h



Extractores centrífugos de doble aspiración con motor directo, para trabajar inmersos en zonas de riesgo de incendio 400 °C/2h, con posibilidad de motor monofásico.

Ventilador:

- Envoltente en chapa de acero galvanizado.
- Turbina a acción en chapa de acero galvanizado.
- Caja de bornes externa.
- Homologación según norma EN 12101-3, con certificación n°: 0370-CPR-0580.

Motor:

- Motores clase H para uso continuo S1 y uso emergencia S2. Con rodamientos a bolas, protección IP55 y 1 o 2 velocidades según modelo.

- Monofásico 230 V 50 Hz y trifásico 230/400 V 50 Hz (hasta 3 kW) y 400/690 V 50 Hz (potencias superiores a 3 kW).
- Temperatura máxima del aire a transportar: Servicio S1 -20 °C +60 °C en continuo. Servicio S2 300 °C/2h, 400 °C/2h.

Acabado:

- Anticorrosivo en chapa de acero galvanizado.

Bajo demanda:

- Extractores con impulsión circular.
- Extractores con salida vertical.

Código de pedido

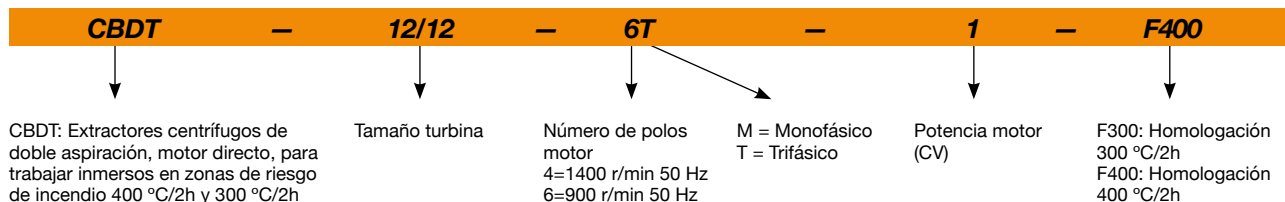

Características técnicas

Modelo	Velocidad (r/min)	Intensidad máxima admisible (A)			Potencia instalada (kW)	Caudal máximo (m³/h)	Nivel presión sonora ¹ dB (A)	Peso aprox. (Kg)
		230V	400V	690V				
CBDT-9/9-4T	1420	2,90	1,70		0,55	3000	59	24
CBDT-9/9-4M	1410	4,10			0,55	3000	59	23
CBDT-10/10-4T	1420	2,90	1,70		0,55	3450	61	26
CBDT-10/10-4M	1410	4,10			0,55	3450	61	25
CBDT-12/12-6T-1	940	4,40	2,60		0,75	4800	58	37
CBDT-12/12-6M-1	920	5,80			0,75	4800	58	37
CBDT-12/12-6T-1.5	945	6,40	3,70		1,10	6200	60	39
CBDT-12/12-6M-1.5	920	8,40			1,10	6200	60	39
CBDT-15/15-6T	950	10,30	5,90		2,20	8250	62	68
CBDT-18/18-6T	970		11,00	6,35	4,00	11800	64	109

¹ Nivel de presión sonora irradiada en dB(A) a 3 m de distancia.



Erp. (Energy Related Products)

Información de la Directiva 2009/125/EC descargable desde la web de SODECA o programa de selección QuickFan.

Características acústicas

Espectro de potencia sonora irradiada Lw(A) en dB(A) por banda de frecuencia en Hz

	63	125	250	500	1000	2000	4000	8000		63	125	250	500	1000	2000	4000	8000
CBDT-9/9-4-0.75	46	56	64	68	73	72	69	61	CBDT-12/12-6-1.5	49	60	65	72	73	73	68	62
CBDT-10/10-4-0.75	48	58	66	70	75	74	71	63	CBDT-15/15-6-3	63	72	74	76	71	70	64	55
CBDT-12/12-6-1	47	58	63	70	71	71	66	60	CBDT-18/18-6-5.5	64	74	76	78	73	72	66	57

Dimensiones mm

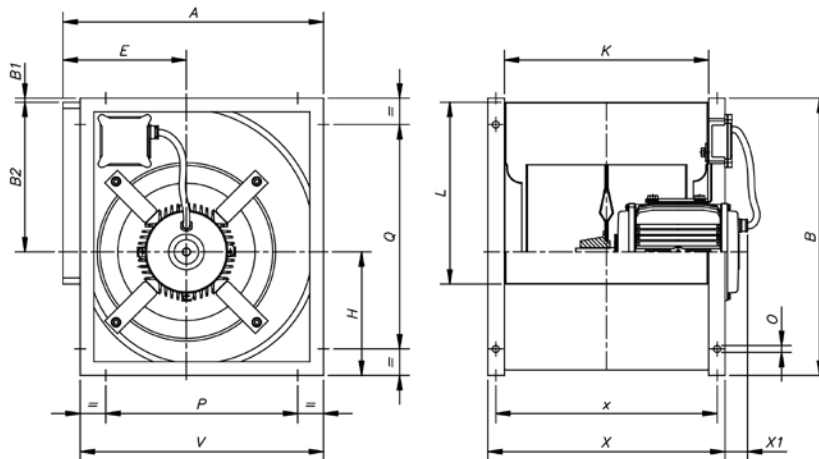

	A	B	B1	B2	E	H	K	L	P	Q	V	X	X1	x	O
CBDT-9/9	390	402	1,5	218	183	181	300	263	280	280	358	360	49	332	9x17
CBDT-10/10	430	448	2	246	202	204	326	292	326	326	398	388	33	360	9x17
CBDT-12/12	501	534	4	290	230	239,5	387	342	384	384	470	448	57	420	9x17
CBDT-15/15	584	630	-	348	265	280	473	405	460	460	550	535	58	507	9x17
CBDT-18/18	694	756	4	415	323	336	540	482	553	608	665	600	85	570	9x17

Situación caja de bornes

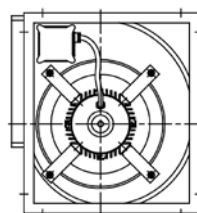

CBDT-9/9
CBDT-10/10
CBDT-12/12
CBDT-15/15

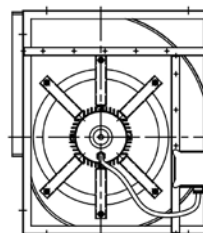

CBDT-18/18

Curvas características

Q= Caudal en m³/h, m³/s y cfm

Pe= Presión estática en mmH₂O, Pa e inwg

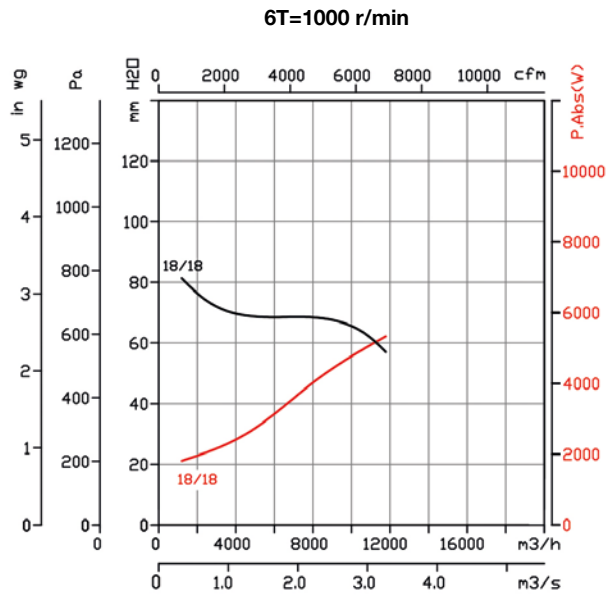
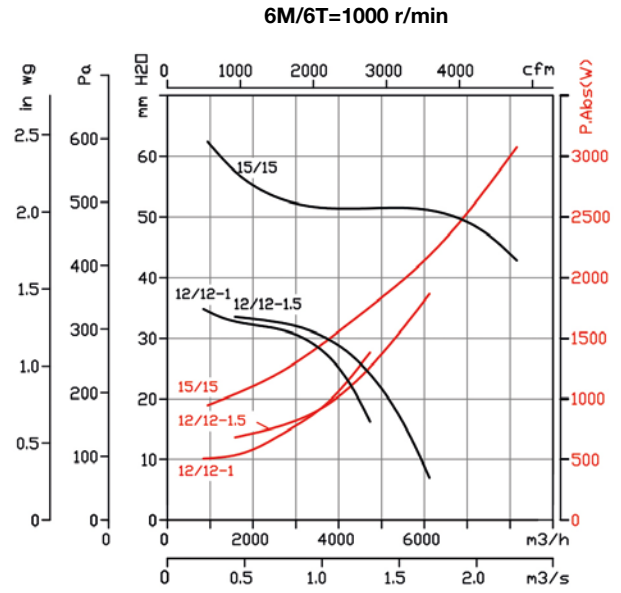
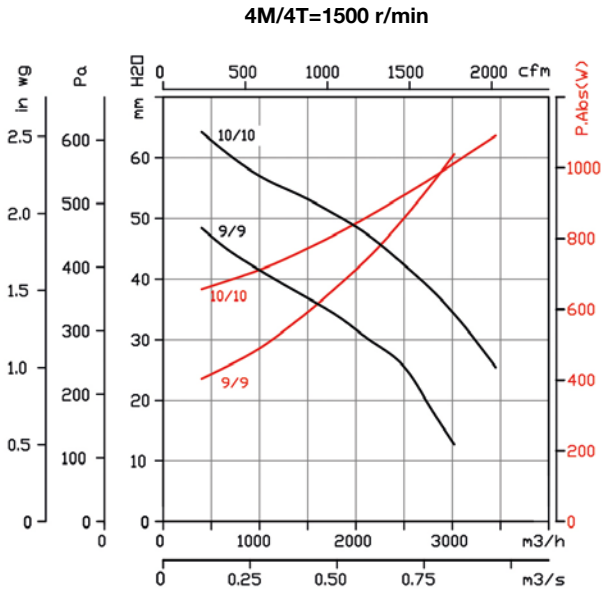

Accesorios



INT



IAT



CABLE BOX



C2V



VSD3/A-RFT
- VSD1/A-RFM



CENTRAL CO



AET



P-400



VIS

CJV/EW



EC TECHNOLOGY CON VSD INTEGRADO



Unidades de extracción de funcionamiento automático, salida de aire vertical, motor EC Technology y control de presión constante para viviendas

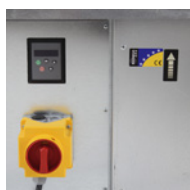

Modelo CJV/EW-1800/T homologado para 400 °C/2h

Ventilador:

- Unidades de extracción con impulsión vertical y dos bocas de extracción circulares.
- Envoltente en chapa de acero galvanizado.
- Turbina a acción en chapa de acero galvanizado.
- Variador electrónico de velocidad (VSD) monofásico, incluido con el ventilador.

Motor:

- Nuevos motores EC síncronos de alta eficiencia (IE4). Equipados con imanes de neodimio de alta intensidad.
- Control sensorless de alta fiabilidad y sin mantenimiento.
- Equipados con rodamientos a bolas de larga duración.
- Protección IP55.
- Temperatura de trabajo ventilador: -25 °C +60 °C.
- CJV/EW-1800/T: Temperatura de trabajo ventilador: Servicio S1 -25 °C +60 °C en continuo. Servicio S2 400 °C/2h.
- Homologación según norma EN 12101-3.

Variador electrónico de velocidad:

- Velocidad ajustada según consigna de presión.
- Control automático PI integrado en el variador y sonda de presión diferencial.
- Parámetros del variador fácilmente configurables mediante Display y Keypad.
- Se suministra con interruptor PARO/MARCHA de seguridad, totalmente cableado y listo para ser instalado.
- Disponibles con entrada monofásica 220-240 V 50/60 Hz.
- Temperatura de trabajo (VSD): -25 °C +50 °C.

Acabado:

- Anticorrosivo en chapa de acero galvanizado preparado para ser instalado en el exterior.

Bajo demanda:

- Ventilador con impulsión horizontal.

Características técnicas

Modelo	Velocidad mín/máx (r/min)	VSD Monofásico 230 V 50/60 Hz Intensidad máxima entrada (A)	Potencia eléctrica máx. (W)	Nivel presión sonora mín/máx Lp dB (A)	Peso aprox. (Kg)
CJV/EW-1800	300/1800	5,2	660	21 / 60	35
CJV/EW-1800/T	300/1800	5,2	660	21 / 60	35



Erp. (Energy Related Products)

Información de la Directiva 2009/125/EC descargable desde la web de SODECA o programa de selección QuickFan

Características acústicas

Espectro de potencia sonora Lw(A) en dB(A) por banda de frecuencia en Hz
Valores irradiados a 1700 m³/h -250 Pa

	63	125	250	500	1000	2000	4000	8000
CJV/EW-1800	44	54	65	72	76	73	71	64
CJV/EW-1800/T	44	54	65	72	76	73	71	64

Dimensiones mm

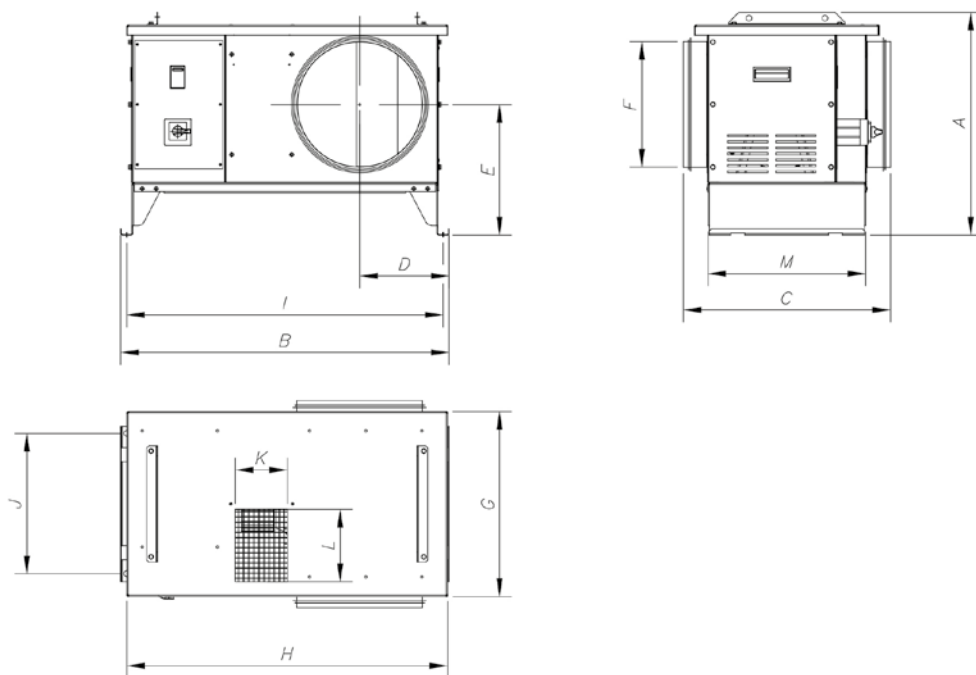

	A	B	C	D	E	F	G	H	I	J	K	L	M
CJV/EW-1800	560	815	520	225	325	315	460	800	780	345	130	180	395
CJV/EW-1800/T	560	815	520	225	325	315	460	800	780	345	130	180	395

Accesorios



Curvas características

Caudal en m³/h. Presión estática en Pa. Potencia eléctrica en W. Presión sonora irradiada a 4 m.

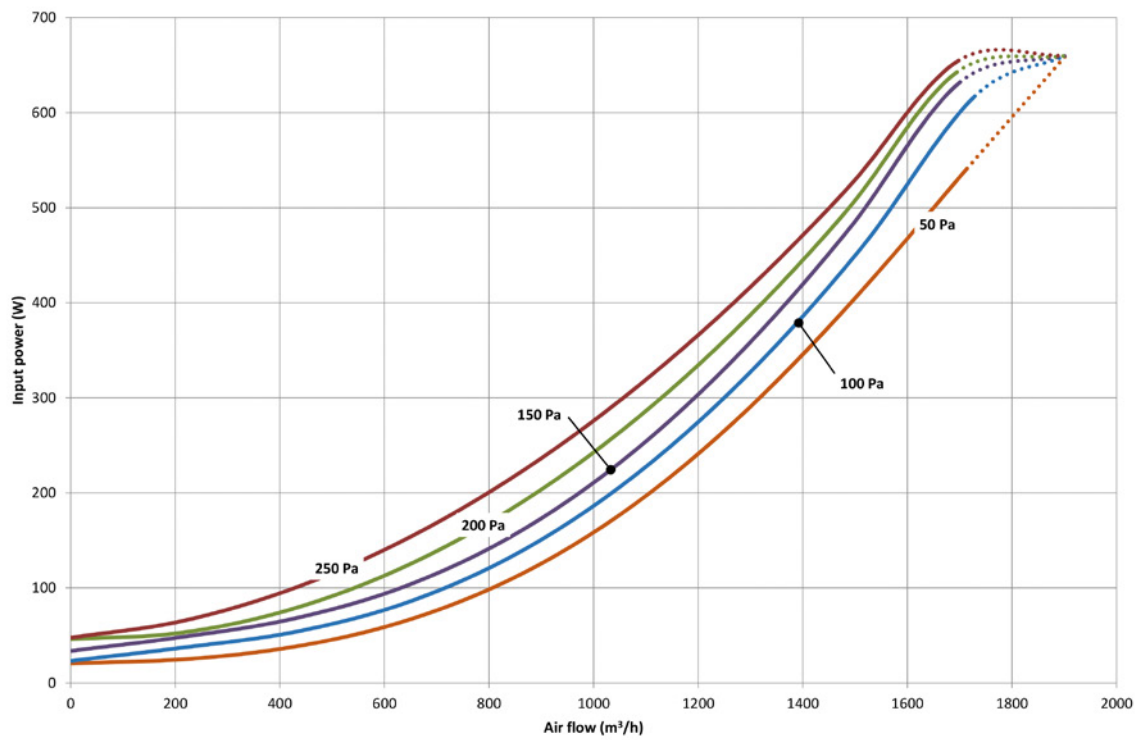
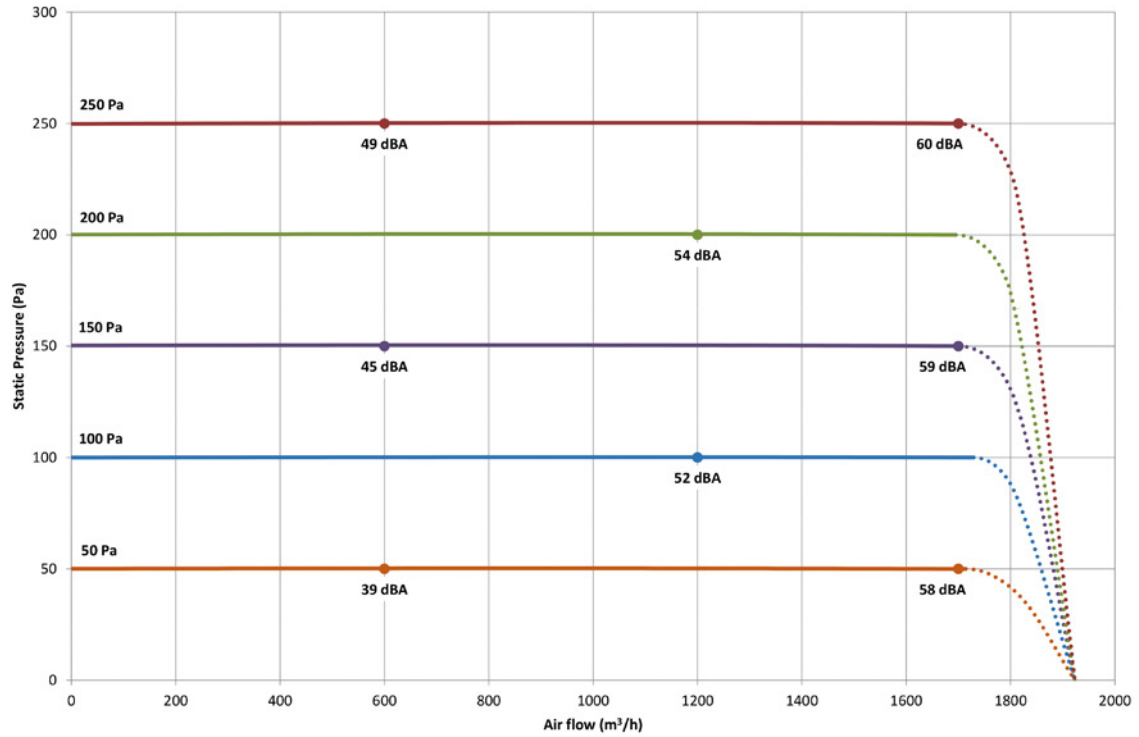

TCR

Extractores centrífugos 400 °C/2h y 300 °C/2h, con turbina a reacción



Extractores centrífugos para trabajar inmersos en zonas de riesgo de incendios 400 °C/2h, de media presión y simple aspiración. De gran robustez. Equipados con turbina a reacción.

Ventilador:

- Envoltente en chapa de acero.
- Turbina a reacción en chapa de acero de gran robustez, con pintura anticorrosiva.
- Homologación según norma EN 12101-3, con certificación n°: 0370-CPR-0384.

Motor:

- Motores con eficiencia IE3 para potencias iguales o superiores a 0,75 kW, excepto monofásicos, 2 velocidades y 8 polos.

- Motores clase H para uso continuo S1 y uso emergencia S2. Con rodamientos a bolas y protección IP55.
- Trifásico 230/400 V 50 Hz (hasta 3 kW) y 400/690 V 50 Hz (potencias superiores a 3 kW).
- Temperatura máxima del aire a transportar: Servicio S1 -25 °C +120 °C en continuo. Servicio S2 300 °C/2h y 400 °C/2h.

Acabado:

- Anticorrosivo en resina de poliéster polimerizada a 190 °C, previo desengrase con tratamiento nanotecnológico libre de fosfatos.

Código de pedido

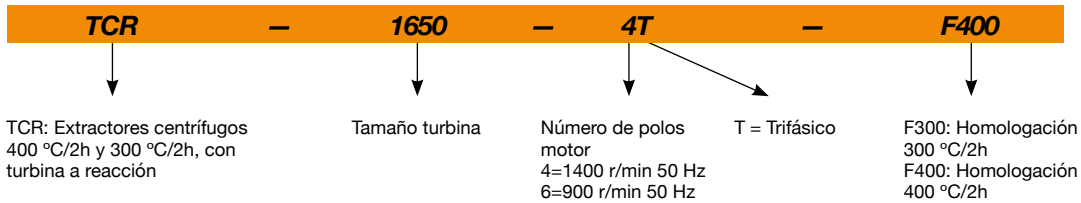

Orientaciones

Suministro standard LG 270

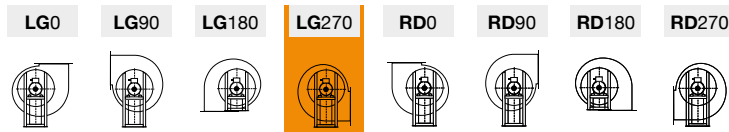

Características técnicas

Modelo	Velocidad (r/min)	Intensidad máxima admisible (A)			Potencia instalada (kW)	Caudal máximo (m³/h)	Nivel presión sonora ¹ dB (A)	Peso aprox. (Kg)
		230V	400V	690V				
TCR-1240-4T IE3	1425	3,08	1,79		0,75	5830	65	76
TCR-1445-4T IE3	1435	4,10	2,37		1,10	8100	68	98
TCR-1650-4T IE3	1140	5,89	3,38		1,50	10600	70	118
TCR-1650-6T IE3	950	3,36	1,93		0,75	7410	60	118
TCR-1856-4T IE3	1455	11,01	6,33		3,00	15240	76	158
TCR-1856-6T IE3	950	4,73	2,72		1,10	10050	68	150
TCR-2063-4T IE3	1465		10,40	6,04	5,50	24490	78	257
TCR-2063-6T IE3	955	6,25	3,62		1,50	16100	68	212
TCR-2271-4T IE3	1480		20,70	11,99	11,00	34760	84	380
TCR-2271-6T IE3	970	12,80	6,36		3,00	23010	75	313

¹ Nivel de presión sonora irradiada en dB(A) a 3 m de distancia.

Características acústicas

Espectro de potencia sonora irradiada Lw(A) en dB(A) por banda de frecuencia en Hz

	63	125	250	500	1000	2000	4000	8000		63	125	250	500	1000	2000	4000	8000
TCR-1240-4T	53	67	73	76	76	77	67	56	TCR-1856-6T	58	66	78	80	77	78	68	57
TCR-1445-4T	56	69	75	80	77	80	75	61	TCR-2063-4T	77	82	88	90	88	85	78	70
TCR-1650-4T	61	71	79	81	80	82	73	63	TCR-2063-6T	66	67	79	79	78	80	70	60
TCR-1650-6T	50	62	69	74	70	66	59	51	TCR-2271-4T	80	81	90	93	95	96	92	79
TCR-1856-4T	66	75	88	84	87	88	82	68	TCR-2271-6T	70	70	84	83	87	87	76	65

Dimensiones mm

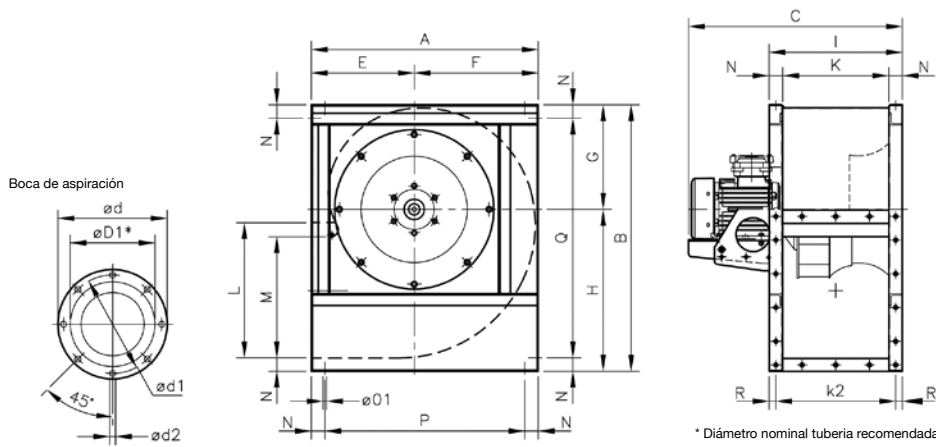

	A	B	C	Ød	Ød1	ØD1*	Ød2	E	F	G	H	M	N	Ø01	P	Q	R
TCR-1240-4T	673	790	634	472	444	400	M8	305	368	310	480	358,5	40	11	593	710	20
TCR-1445-4T	765	880	727	522	494	450	M8	350	415	339	541	407	45	11	675	790	20
TCR-1650-4T	832	970	770,5	582	555	500	M10	375	457	378	592	445	45	13	742	880	20
TCR-1650-6T	832	970	770,5	582	555	500	M10	375	457	378	592	445	45	13	742	880	20
TCR-1856-4T	925	1084	857,5	645	615	560	M10	415	510	424	660	493	50	13	825	984	25
TCR-1856-6T	925	1084	828	645	615	560	M10	415	510	424	660	493	50	13	825	984	25
TCR-2063-4T	1037	1218	955	720	688	630	M10	465	572	477	741	530	60	13	917	1098	30
TCR-2063-6T	1037	1218	932	720	688	630	M10	465	572	477	741	530	60	13	917	1098	30
TCR-2271-4T	1173	1375	1149	800	768	710	M12	525	648	538	837	603,5	65	13	1043	1245	32,5
TCR-2271-6T	1173	1375	1112	800	768	710	M12	525	648	538	837	603,5	65	13	1043	1245	32,5

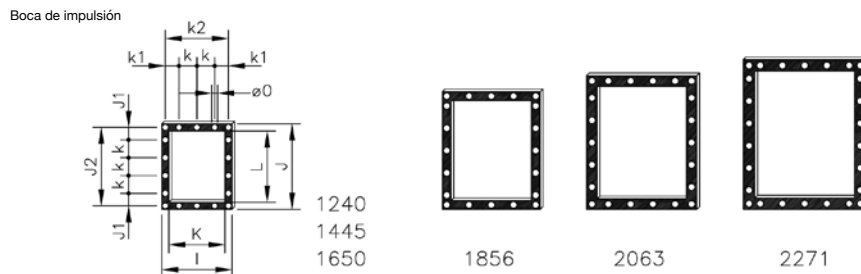

	I	J	J1	J2	K	k	k1	k2	L	Ø0
TCR-1240	395	480	70	440	315	100	77,5	355	400	11
TCR-1445	445	540	99	498	355	100	102,5	405	450	11
TCR-1650	490	590	87,5	550	400	125	100	450	500	13
TCR-1856	550	660	55	610	450	125	125	500	560	13
TCR-2063	620	750	95	690	500	125	92,5	560	630	13
TCR-2271	690	840	75	775	560	125	62,5	625	710	13

Curvas características

Q= Caudal en m³/h, m³/s y cfm

Pe= Presión estática en mmH₂O, Pa e inwg

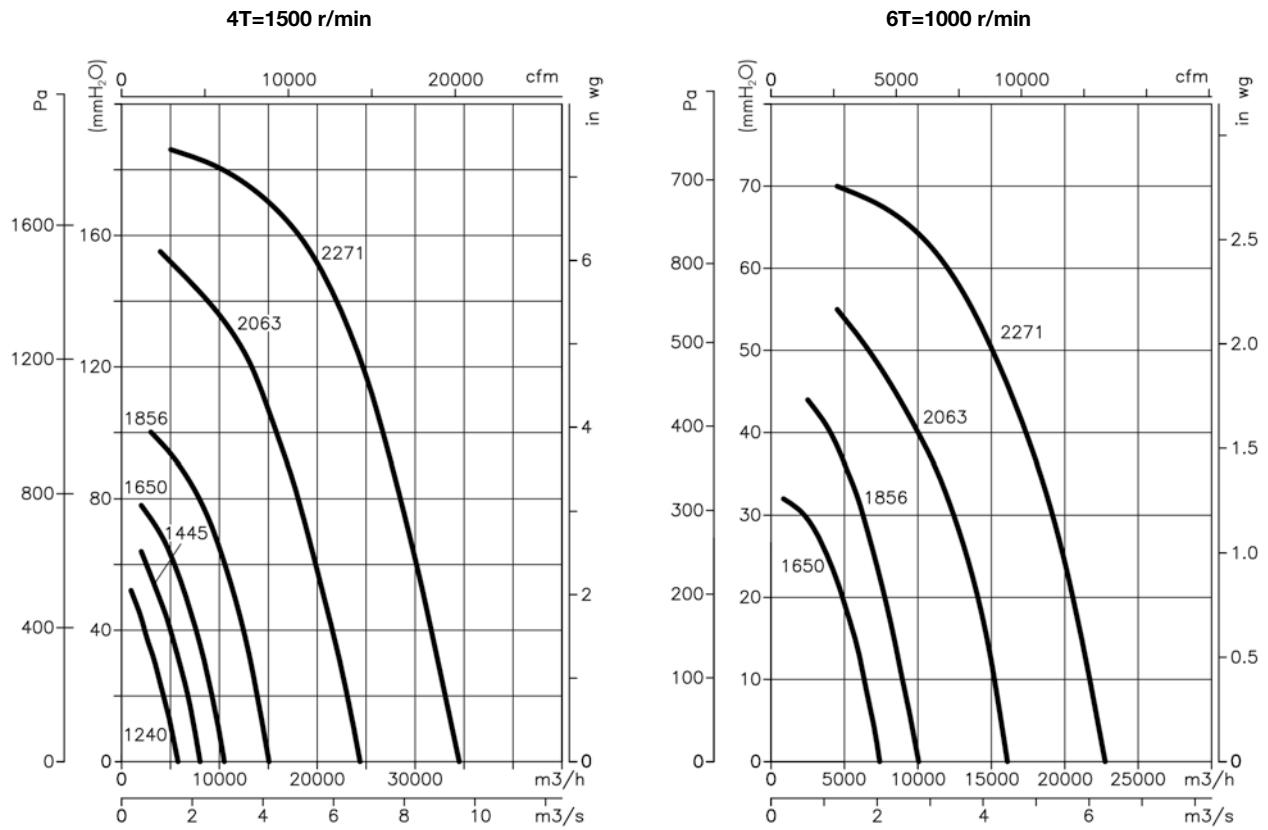

Accesorios



INT



IAT



C2V



RPA



B



BD



BIC



ACE ACE/400



CABLE BOX



AET



CENTRAL CO



VSD3/A-RFT
- VSD1/A-RFM

CJS

Unidades de extracción 400 °C/2h y 300 °C/2h, con tapas intercambiables



Unidades de extracción con caja aislada acústicamente con panel tipo sándwich. Para trabajar inmersas en zonas de riesgo de incendios 400 °C/2h.

Ventilador:

- Estructura en chapa de acero galvanizado, con aislamiento térmico y acústico.
- Turbina a reacción en chapa de acero.
- Tapas intercambiables para tener la impulsión en cualquiera de los laterales.
- De serie se suministra con impulsión rectangular. Con el accesorio TAC puede convertirse la impulsión en circular.
- Homologación según norma EN 12101-3, con certificación n°: 0370-CPR-0398.
- Dirección aire sentido lineal.

Motor:

- Motores clase H para uso continuo S1 y uso emergencia S2. Con rodamientos a bolas, protección IP55 y 1 o 2 velocidades según modelo.

- Motores con eficiencia IE3 para potencias iguales o superiores a 0,75 kW, excepto monofásicos, 2 velocidades y 8 polos.
- Trifásico 230/400 V 50 Hz (hasta 3 kW) y 400/690 V 50 Hz (potencias superiores a 3 kW).
- Temperatura máxima del aire a transportar: Servicio S1 -20 °C +40 °C en continuo, apto también para climas cálidos con temperaturas hasta 50 °C. Servicio S2 300 °C/2h, 400 °C/2h.

Acabado:

- Anticorrosivo en chapa de acero galvanizado.

Bajo demanda:

- Extractores con motor de 2 velocidades.
- Ejecución especial para trabajo vertical.

Código de pedido

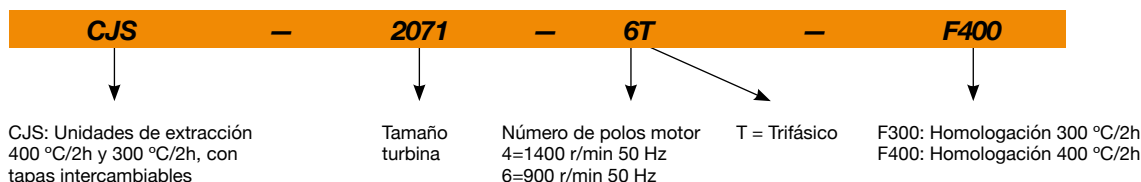

Características técnicas

Modelo	Velocidad (r/min)	Intensidad máxima admisible (A)			Potencia instalada (kW)	Caudal máximo (m³/h)	Nivel presión sonora¹ dB (A)	Peso aprox. (Kg)
		230V	400V	690V				
CJS-1850-4T IE3	1440	5,89	3,38		1,50	6670	68	87
CJS-2056-4T IE3	1465	7,86	4,52		2,20	9460	70	133
CJS-2056-6T IE3	950	3,36	1,93		0,75	6510	55	128
CJS-2071-4T IE3	1480		20,70	11,99	11,00	25000	83	285
CJS-2071-6T-3 IE3	960	9,78	5,62		2,20	12480	70	156
CJS-2071-6T-5.5 IE3	970		8,37	4,82	4,00	16020	68	251
CJS-2263-4T IE3	1465		10,40	6,04	5,50	17400	74	196
CJS-2263-6T IE3	950	4,73	2,72		1,10	8970	59	139
CJS-2880-6T IE3	970		8,37	4,82	4,00	17070	71	249

¹ Nivel de presión sonora irradiada en dB(A) a 3 m de distancia.



Erp. (Energy Related Products)

Información de la Directiva 2009/125/EC descargable desde la web de SODECA o programa de selección QuickFan.

Características acústicas

Espectro de potencia sonora irradiada Lw(A) en dB(A) por banda de frecuencia en Hz

	63	125	250	500	1000	2000	4000	8000
CJS-1850-4T	66	72	77	78	81	80	73	68
CJS-2056-4T	67	73	79	79	83	83	75	68
CJS-2056-6T	52	58	64	64	68	68	60	53
CJS-2071-4T	80	81	89	92	95	96	92	78
CJS-2071-6T-3	66	65	80	79	83	83	72	61
CJS-2071-6T-5.5	65	66	74	77	80	81	77	63
CJS-2263-4T	74	79	85	87	85	82	75	67
CJS-2263-6T	59	64	70	72	70	67	60	52
CJS-2880-6T	68	74	79	80	84	83	76	69

Dimensiones mm

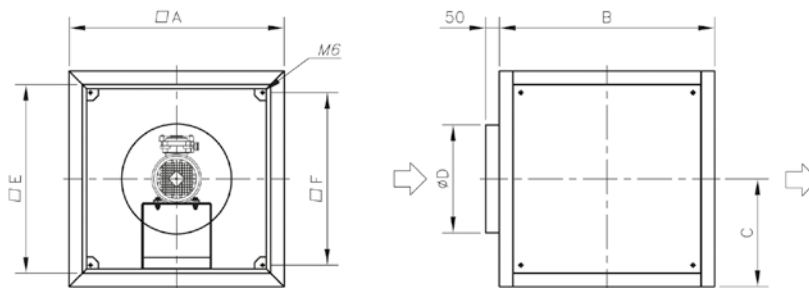

	A	B	C	D	E	F
CJS-1850-4T	800	800	400	400	700	640
CJS-2056-4T	925	925	462,5	450	825	765
CJS-2056-6T	925	925	462,5	450	825	765
CJS-2071-4T	1060	1060	530	710	960	900
CJS-2071-6T-3	1000	1000	500	630	900	840
CJS-2071-6T-5.5	1060	1060	530	710	960	900
CJS-2263-4T	1000	1000	500	630	900	840
CJS-2263-6T	925	925	462,5	560	825	765
CJS-2880-6T	1060	1060	530	710	960	900

Accesorios



INT



IAT



C2V



RPA



TAC



CABLE BOX



AET



CENTRAL CO



VSD3/A-RFT
- VSD1/A-RFM

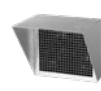

VIS

Curvas características

Q= Caudal en m³/h, m³/s y cfm

Pe= Presión estática en mmH₂O, Pa e inwg

4T=1500 r/min

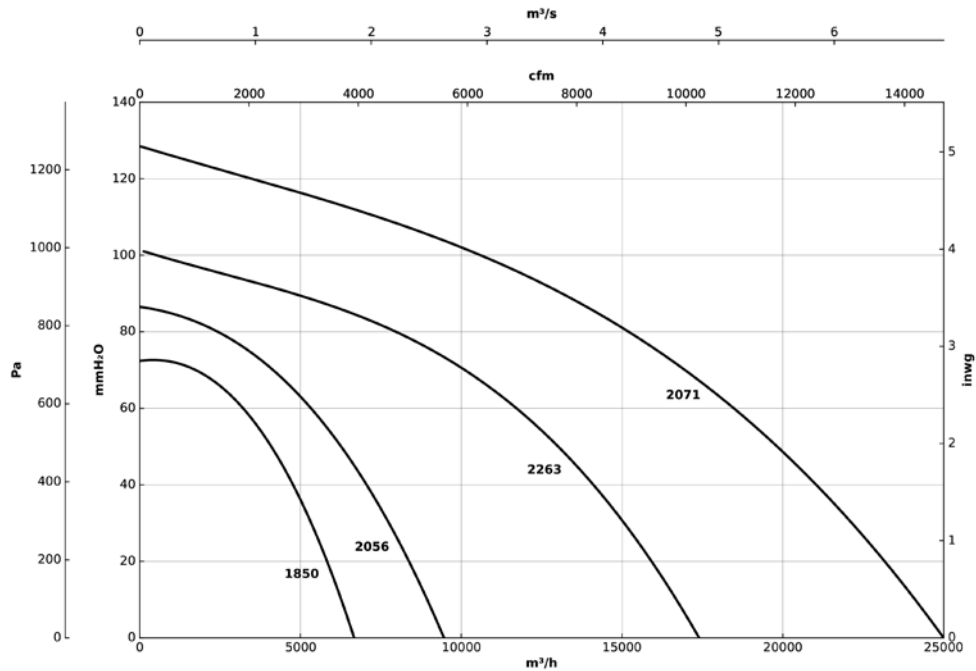

6T=1000 r/min

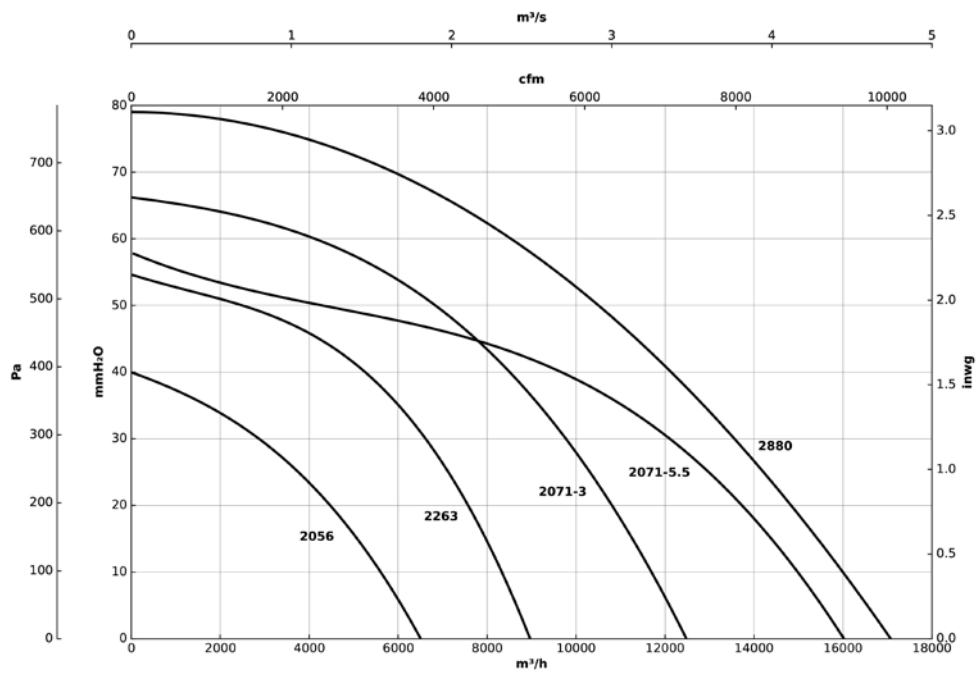

CJMD

Unidades de extracción 400 °C/2h y 300 °C/2h, con entrada y salida lineal



Unidades de extracción con caja aislada acústicamente. Para trabajar inmersas en zonas de riesgo de incendios 400 °C/2h.

Ventilador:

- Estructura en chapa de acero galvanizado, con aislamiento térmico y acústico.
- Turbina en chapa de acero.
- Homologación según norma EN 12101-3, con certificación nº: 0370-CPR-0399.
- Dirección aire sentido lineal.

Motor:

- Motores clase H para uso continuo S1 y uso emergencia S2. Con rodamientos a bolas y protección IP55.

- Motores con eficiencia IE3 para potencias iguales o superiores a 0,75 kW, excepto monofásicos, 2 velocidades y 8 polos.
- Trifásico 230/400 V 50 Hz (hasta 3 kW) y 400/690 V 50 Hz (potencias superiores a 3 kW).
- Temperatura máxima del aire a transportar: Servicio S1 -25 °C +40 °C en continuo, apto también para climas cálidos con temperaturas hasta 50 °C. Servicio S2 300 °C/2h, 400 °C/2h.

Acabado:

- Anticorrosivo en chapa de acero galvanizado.

Bajo demanda:

- Extractores con motor de 2 velocidades.

Código de pedido

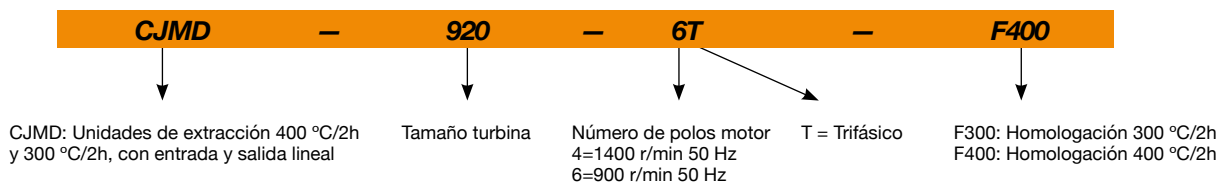

Características técnicas

Modelo	Velocidad (r/min)	Intensidad máxima admisible (A)			Potencia instalada (kW)	Caudal máximo (m³/h)	Nivel presión sonora ¹ dB (A)	Peso aprox. (Kg)
		230V	400V	690V				
CJMD-600-4T IE3	1425	3,08	1,79		0,75	2440	51	68
CJMD-665-4T IE3	1435	4,10	2,37		1,10	3380	55	80
CJMD-730-4T IE3	1465	7,86	4,52		2,20	5000	59	100
CJMD-730-6T IE3	950	3,36	1,93		0,75	3490	45	95
CJMD-800-4T IE3	1450		7,95	4,61	4,00	6850	64	132
CJMD-800-6T IE3	955	6,25	3,62		1,50	5270	51	116
CJMD-825-6T IE3	960	9,78	5,62		2,20	7370	55	146
CJMD-885-6T IE3	960	9,78	5,62		2,20	8100	58	164
CJMD-905-4T IE3	1425	3,08	1,79		0,75	5830	59	133
CJMD-920-6T IE3	960	9,78	5,62		2,20	7270	66	184
CJMD-960-4T IE3	1435	4,10	2,37		1,10	8100	62	185
CJMD-1020-4T IE3	1440	5,89	3,38		1,50	10600	64	198
CJMD-1020-6T IE3	950	3,36	1,93		0,75	7410	54	197
CJMD-1160-6T IE3	970		8,37	4,82	4,00	11050	68	263
CJMD-1225-4T IE3	1455	11,01	6,33		3,00	15240	70	279
CJMD-1225-6T IE3	950	4,73	2,72		1,10	10050	62	274
CJMD-1330-4T IE3	1465		10,40	6,04	5,50	24490	72	409
CJMD-1330-6T IE3	955	6,25	3,62		1,50	16100	62	370
CJMD-1550-4T IE3	1480		20,70	11,99	11,00	34760	78	553
CJMD-1550-6T IE3	970	12,80	6,36		3,00	23010	69	501

¹ Nivel de presión sonora irradiada en dB(A) a 3 m de distancia.

Características acústicas

Espectro de potencia sonora irradiada Lw(A) en dB(A) por banda de frecuencia en Hz

	63	125	250	500	1000	2000	4000	8000		63	125	250	500	1000	2000	4000	8000
CJMD-600-4T	33	43	54	61	65	62	60	53	CJMD-960-4T	51	64	70	75	72	75	70	56
CJMD-665-4T	37	47	58	65	69	66	64	57	CJMD-1020-4T	56	66	74	76	75	77	68	58
CJMD-730-4T	41	51	62	69	73	70	68	61	CJMD-1020-6T	45	57	64	69	65	61	54	46
CJMD-730-6T	27	37	48	55	59	56	54	47	CJMD-1160-6T	50	60	71	78	82	80	78	70
CJMD-800-4T	47	56	67	74	78	76	74	67	CJMD-1225-4T	61	70	83	79	82	83	77	63
CJMD-800-6T	34	43	54	61	65	63	61	54	CJMD-1225-6T	53	61	73	75	72	73	63	52
CJMD-825-6T	38	47	58	65	69	67	65	58	CJMD-1330-4T	72	77	83	85	83	80	73	65
CJMD-885-6T	41	50	61	68	72	70	68	61	CJMD-1330-6T	61	62	74	74	73	75	65	55
CJMD-905-4T	48	62	68	71	71	72	62	51	CJMD-1550-4T	75	76	85	88	90	91	87	74
CJMD-920-6T	48	58	69	76	80	78	76	68	CJMD-1550-6T	65	65	79	78	82	82	71	60

Dimensiones mm

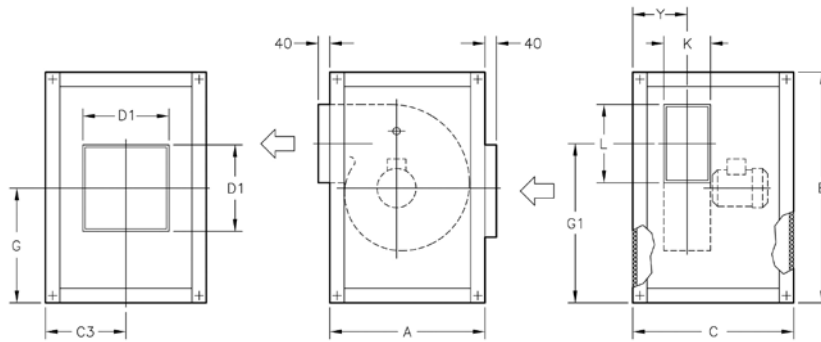

	A	B	C	C3	D1	G	G1	K	L	Y
CJMD-600-4T	735	755	604	302	400	378	500	140	215	190
CJMD-665-4T	790	810	678	339	400	405	540	165	250	215
CJMD-730-4T	855	874	748	374	400	437	577	180	295	237
CJMD-730-6T	855	874	748	374	400	437	577	180	295	237
CJMD-800-4T	941	961	798	399	500	481	653	200	320	264
CJMD-800-6T	941	961	798	399	500	481	653	200	320	264
CJMD-825-6T	1039	1059	892	446	500	530	770	230	280	296
CJMD-885-6T	1148	1168	938	469	500	585	849	250	320	330
CJMD-905-4T	970	990	896	448	500	495	636	315	400	398
CJMD-920-6T	1268	1287	954	477	600	644	945	284	360	372
CJMD-960-4T	1060	1080	966	483	600	540	694	355	450	443
CJMD-1020-4T	1150	1170	1038	519	800	585	756	400	500	490
CJMD-1020-6T	1150	1170	1038	519	800	585	756	400	500	490
CJMD-1160-6T	1375	1395	1098	549	800	698	999	315	450	414
CJMD-1225-4T	1204	1284	1258	629	800	642	836	450	560	545
CJMD-1225-6T	1204	1284	1258	629	800	642	836	450	560	545
CJMD-1330-4T	1338	1418	1474	737	800	709	921	500	630	620
CJMD-1330-6T	1338	1418	1474	737	800	709	921	500	630	620
CJMD-1550-4T	1495	1575	1648	824	1000	788	1032	560	710	675
CJMD-1550-6T	1495	1575	1648	824	1000	788	1032	560	710	675

Curvas características

Q= Caudal en m³/h, m³/s y cfm

Pe= Presión estática en mmH₂O, Pa e inwg

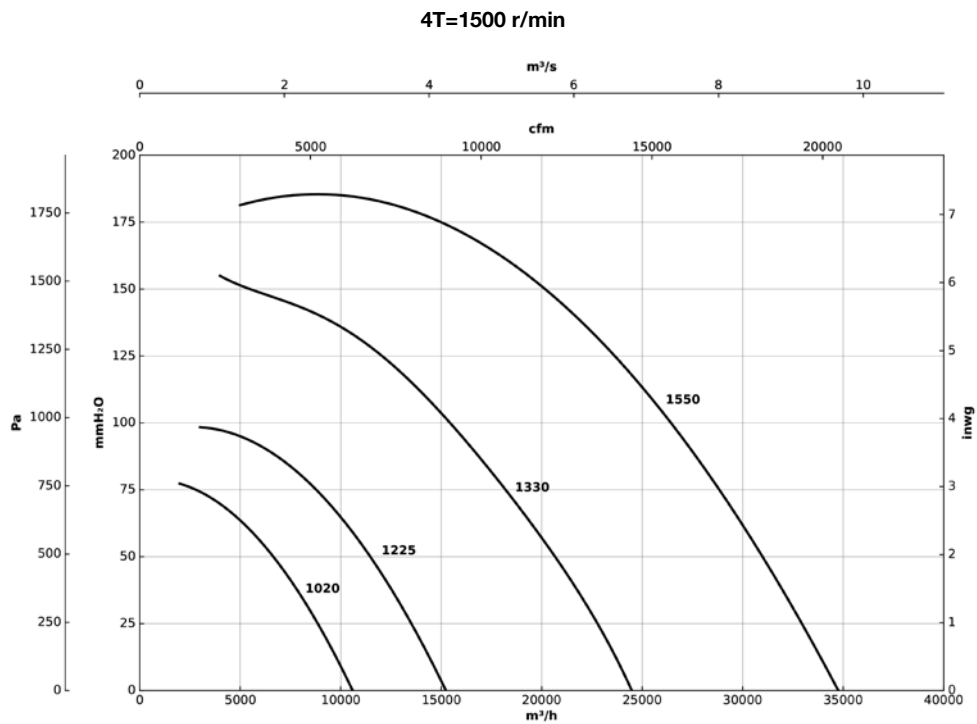
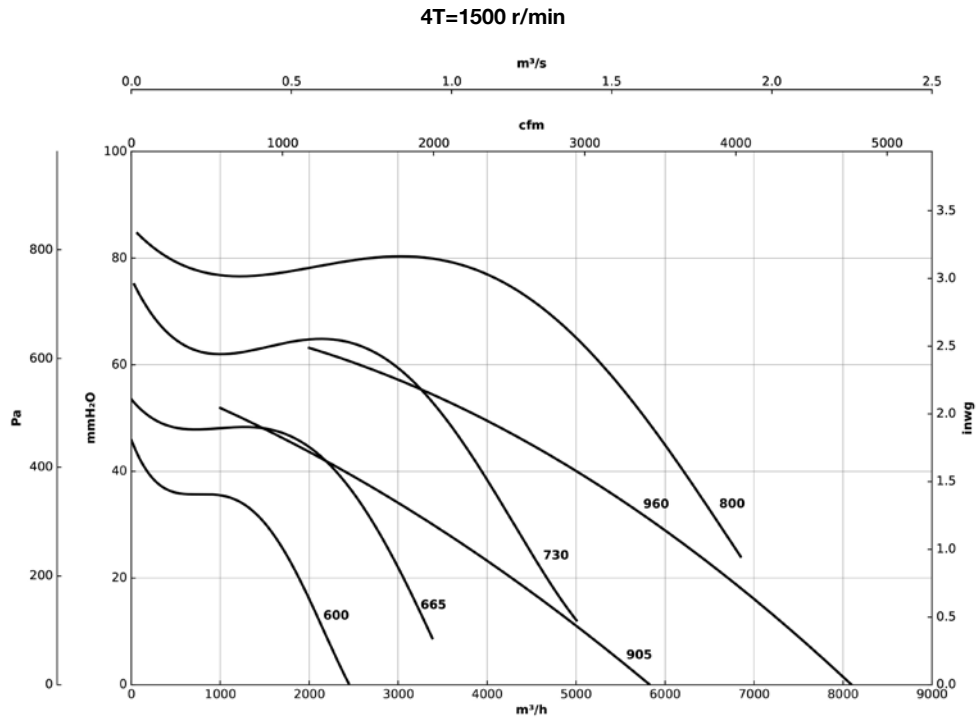

Curvas características

Q= Caudal en m³/h, m³/s y cfm

Pe= Presión estática en mmH₂O, Pa e inwg

6T=1000 r/min

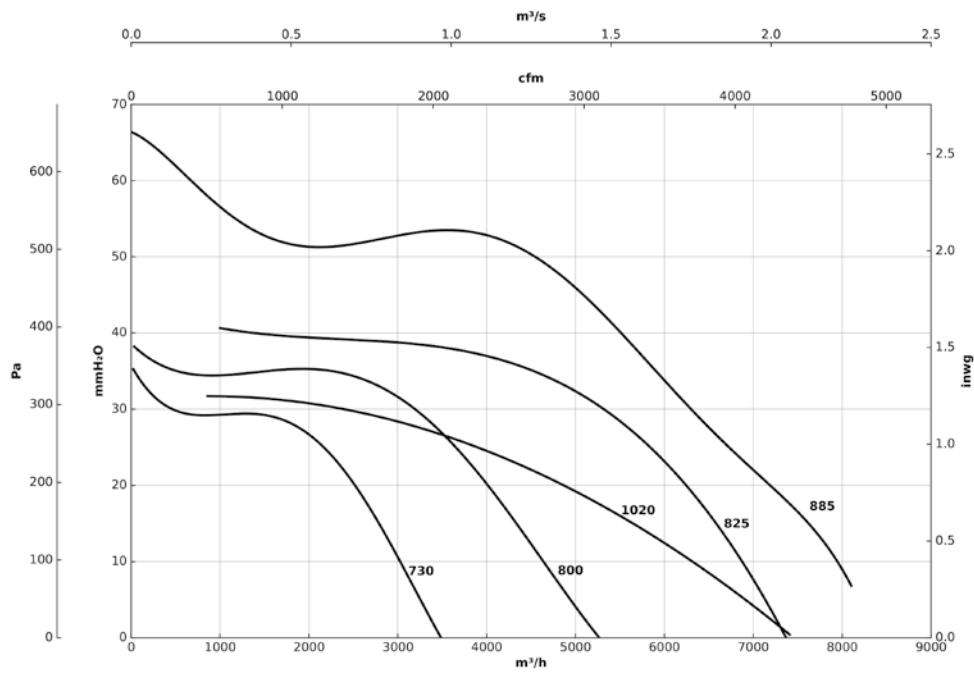

6T=1000 r/min

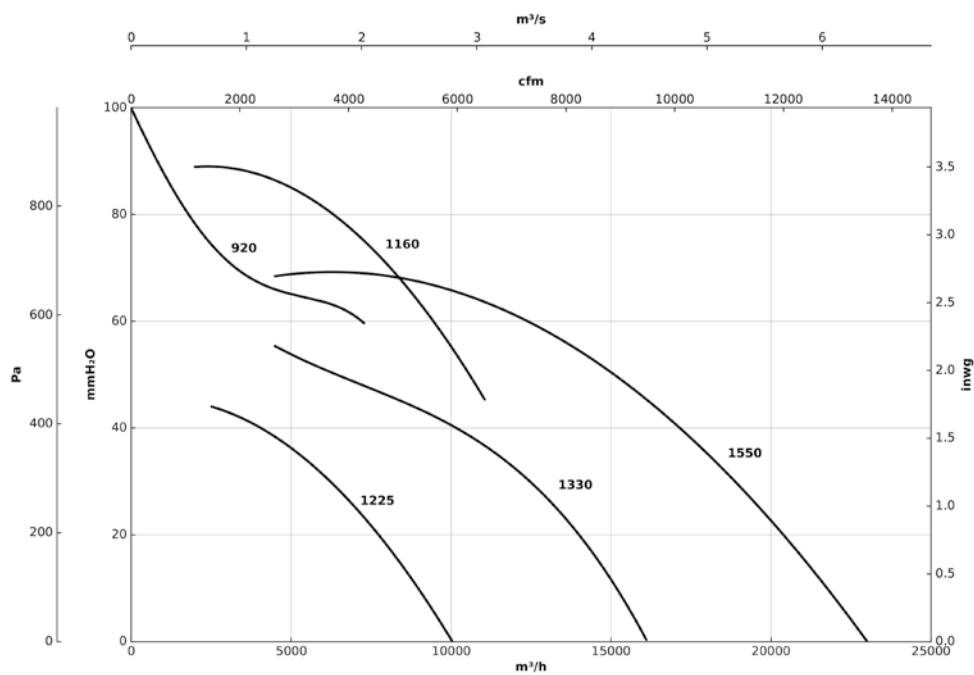

Accesorios



INT



IAT



C2V



RPA



B



BD



BIC



ACE ACE/400



CABLE BOX



AET



CENTRAL CO



VSD3/A-RFT
- VSD1/A-RFM

TCR/R

Extractores centrífugos 400 °C/2h, con turbina a reacción



Turbina a reacción de alto rendimiento, y gran robustez

Extractores centrífugos 400 °C/2h, para trabajar en el exterior de la zona de riesgo de incendios. De simple aspiración y gran robustez. Equipados con turbina a reacción.

Ventilador:

- Envoltente en chapa de acero.
- Turbina a reacción en chapa de acero de gran robustez, con pintura anticorrosiva.
- Homologación según norma EN 12101-3, con certificación n°: 0370-CPR-0400.

Motor:

- Motores clase F con rodamientos a bolas y protección IP55.
- Motores con eficiencia IE3 para potencias iguales o superiores a 0,75 kW, excepto monofásicos, 2 velocidades y 8 polos.

- Trifásico 230/400 V 50 Hz (hasta 4 kW) y 400/690 V 50 Hz (potencias superiores a 4 kW).
- Temperatura máxima del aire a transportar: Servicio S1 -20 °C +250 °C en continuo. Servicio S2 300 °C/2h y 400 °C/2h.

Acabado:

- Anticorrosivo en resina de poliéster polimerizada a 190 °C, previo desengrase con tratamiento nanotecnológico libre de fosfatos.

Bajo demanda:

- Extractores con motor de 2 velocidades.
- Extractores a transmisión.

Código de pedido

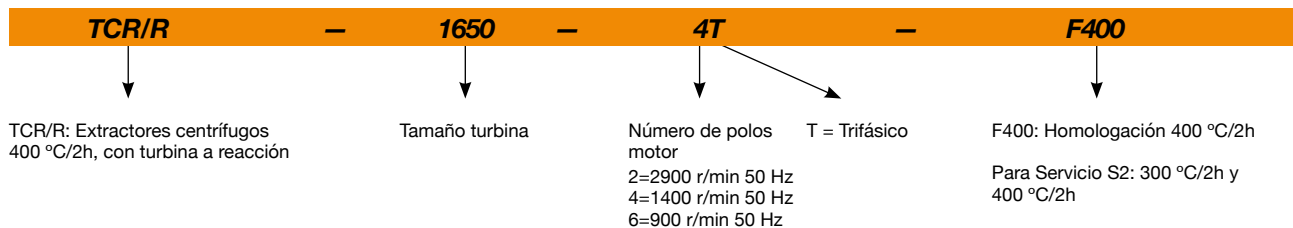

Características técnicas

Modelo	Velocidad (r/min)	Intensidad máxima admisible (A)			Potencia instalada (kW)	Caudal máximo (m³/h)	Nivel presión sonora dB (A)	Peso aprox. (Kg)
		230V	400V	690V				
TCR/R-1240-2T IE3	2900	13,00	7,50		4,00	11110	82	102
TCR/R-1240-4T IE3	1420	2,82	1,62		0,75	5830	67	72
TCR/R-1445-2T IE3	2930		14,10	8,17	7,50	16560	85	122
TCR/R-1445-4T IE3	1455	4,07	2,34		1,10	8100	70	97
TCR/R-1650-4T IE3	1440	5,41	3,11		1,50	10600	72	122
TCR/R-1650-6T IE3	940	3,36	1,93		0,75	7450	62	114
TCR/R-1856-4T IE3	1440	10,70	6,15		3,00	15240	78	157
TCR/R-1856-6T IE3	945	4,68	2,69		1,10	10040	70	151
TCR/R-2063-4T IE3	1465		10,30	5,97	5,50	24490	80	248
TCR/R-2063-6T IE3	950	6,43	3,70		1,50	16140	70	213
TCR/R-2271-4T IE3	1470		20,90	12,10	11,00	34760	82	340
TCR/R-2271-6T IE3	970	12,00	6,91		3,00	23000	77	280



Erp. (Energy Related Products)

Información de la Directiva 2009/125/EC descargable desde la web de SODECA o programa de selección QuickFan

Características acústicas

Los valores indicados, se determinan mediante medidas de nivel de presión y potencia sonora en dB(A) obtenidas en campo libre a una distancia equivalente a dos veces la envergadura del ventilador más el diámetro de la turbina, con un mínimo de 1,5 m.

Espectro de potencia sonora Lw(A) en dB(A) por banda de frecuencia en Hz

	63	125	250	500	1000	2000	4000	8000		63	125	250	500	1000	2000	4000	8000
TCR/R-1240-2T	68	83	81	93	90	94	96	83	TCR/R-1856-4T	69	78	91	87	90	91	85	71
TCR/R-1240-4T	56	40	76	79	79	80	70	59	TCR/R-1856-6T	61	69	81	83	80	81	71	60
TCR/R-1445-2T	73	85	83	95	93	97	99	89	TCR/R-2063-4T	80	85	91	93	91	88	81	73
TCR/R-1445-4T	59	72	78	83	80	83	78	64	TCR/R-2063-6T	69	70	82	82	81	83	73	63
TCR/R-1650-4T	64	74	82	84	83	85	76	66	TCR/R-2271-4T	79	80	89	92	94	95	91	78
TCR/R-1650-6T	53	65	72	77	73	69	62	54	TCR/R-2271-6T	73	73	87	86	90	90	79	68

Orientaciones

Suministro standard LG 270

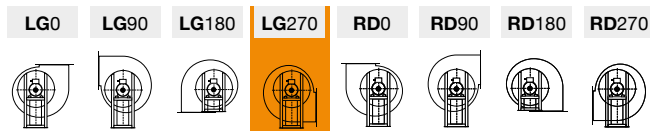

Dimensiones mm

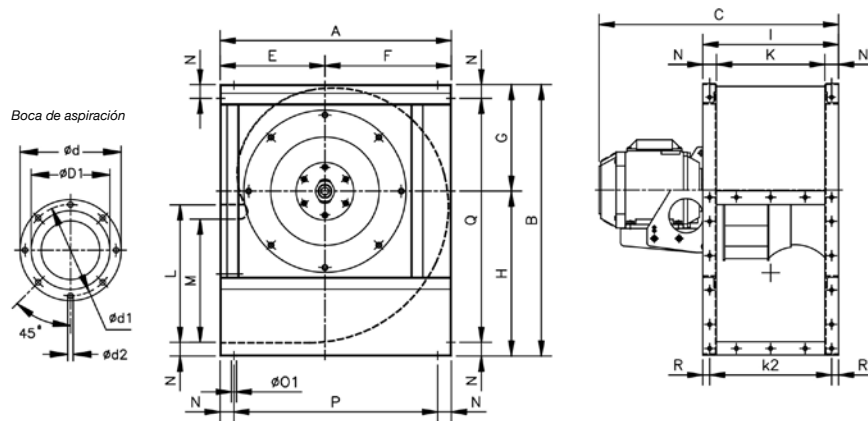

	A	B	C	Ød	Ød1	ØD1*	Ød2	E	F	G	H	M	N	Ø01	P	Q	R
TCR/R-1240-2T	673	790	734	472	444	319	M8	305	368	310	480	358,5	40	11	593	710	20
TCR/R-1240-4T	673	790	634	472	444	319	M8	305	368	310	480	358,5	40	11	593	710	20
TCR/R-1445-2T	765	880	827	524	494	358	M10	350	415	340	540	407	45	11	675	790	20
TCR/R-1445-4T	765	880	699	524	494	358	M10	350	415	340	540	407	45	11	675	790	20
TCR/R-1650-4T	832	970	953	582	555	401	M10	375	457	378	592	446	45	13	742	880	20
TCR/R-1650-6T	832	970	772,5	582	555	401	M10	375	457	378	592	446	45	13	742	880	20
TCR/R-1856-4T	925	1084	880	645	615	457	M10	415	510	426	658	493	50	13	825	984	25
TCR/R-1856-6T	925	1084	825	645	615	457	M10	415	510	426	658	493	50	13	825	984	25
TCR/R-2063-4T	1037	1218	981	720	688	507	M10	465	572	477	741	530	60	13	917	1098	30
TCR/R-2063-6T	1037	1218	932	720	688	507	M10	465	572	477	741	530	60	13	917	1098	30
TCR/R-2271-4T	1173	1375	1197	800	768	575	M10	525	648	538	837	603,5	65	13	1043	1245	32,5
TCR/R-2271-6T	1173	1375	1095	800	768	575	M10	525	648	538	837	603,5	65	13	1043	1245	32,5

* Diámetro nominal tubería recomendada

Dimensiones mm

Boca de impulsión

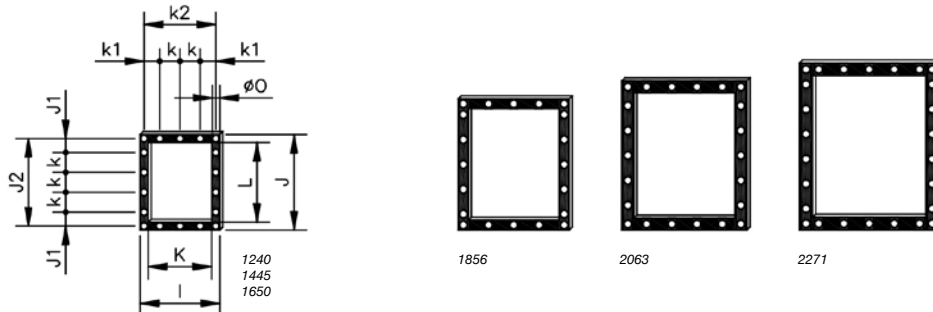

	I	J	J1	J2	K	k	k1	k2	L	Ø0
TCR/R-1240-2T	395	480	70	440	315	100	77,5	355	400	13
TCR/R-1240-4T	395	480	70	440	315	100	77,5	355	400	13
TCR/R-1445-2T	445	540	99	498	355	100	102,5	405	450	11
TCR/R-1445-4T	445	540	99	498	355	100	102,5	405	450	11
TCR/R-1650-4T	490	590	87,5	550	400	125	100	450	500	13
TCR/R-1650-6T	490	590	87,5	550	400	125	100	450	500	13
TCR/R-1856-4T	550	660	55	610	450	125	125	500	560	13
TCR/R-1856-6T	550	660	55	610	450	125	125	500	560	13
TCR/R-2063-4T	620	750	95	690	500	125	92,5	560	630	13
TCR/R-2063-6T	620	750	95	690	500	125	92,5	560	630	13
TCR/R-2271-4T	690	840	75	778	560	125	62,5	625	710	13
TCR/R-2271-6T	690	840	75	778	560	125	62,5	625	710	13

Accesorios



INT



IAT



CABLE BOX



C2V



VSD3/A-RFT
- VSD1/A-RFM



CENTRAL CO



AET



RPA



B



BD



BIC



VIS



ACE ACE/400



TEJ



S

Curvas características

Q= Caudal en m³/h, m³/s y cfm

Pe= Presión estática en mmH₂O, Pa e in wg

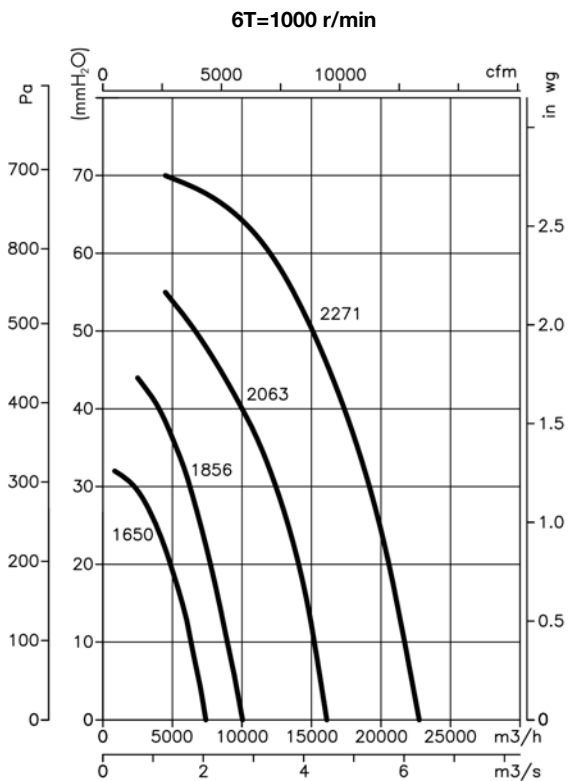
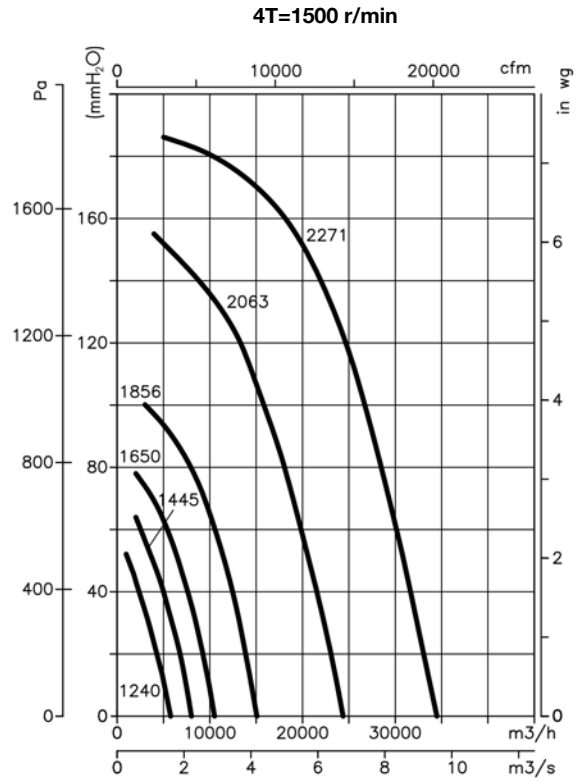
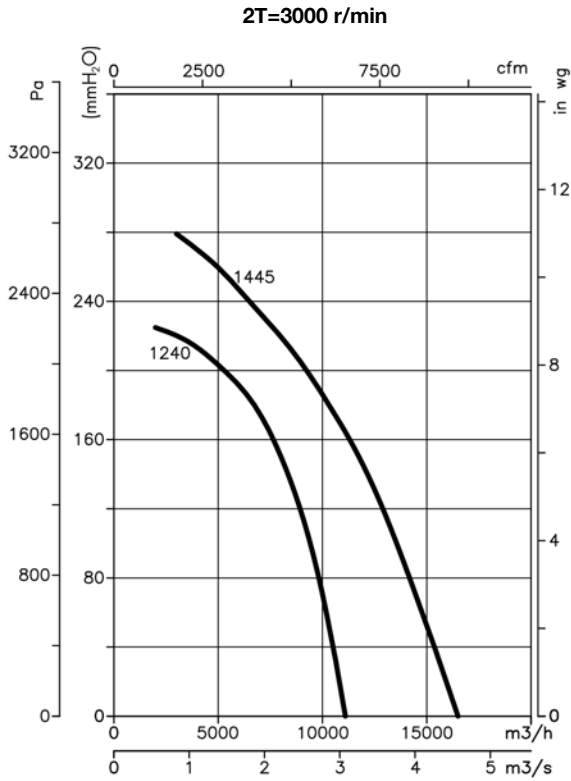

TCR/R/EW



Extractores centrífugos 400 °C/2h, con turbina a reacción equipados con motor asíncrono de alta eficiencia IE3 regulable electrónicamente



VARIADOR VELOCIDAD
VSD: Variador electrónico de velocidad.
VSD1/A-RFM
VSD3/A-RFT
Suministro según pedido

CONTROL
Suministro como accesorio opcional

ALIMENTACIÓN
VSD1/A-RFM:
220-240 V 50/60 Hz
VSD3/A-RFT:
380-415 V 50/60 Hz

Extractores centrífugos 400 °C/2h, para trabajar en el exterior de la zona de riesgo de incendios, de simple aspiración y gran robustez, equipados con turbina a reacción, equipados con motor asíncrono de alta eficiencia IE3 regulable electrónicamente.

Ventilador:

- Envoltorio en chapa de acero.
- Turbina a reacción en chapa de acero de gran robustez, con pintura anticorrosiva.
- Homologación según norma EN 12101-3.

Motor:

- Nuevos motores AC asíncronos de alta eficiencia (IE3).
- Equipados con rodamientos a bolas de larga duración. Protección IP55.
- Trifásico 230/400 V 50 Hz (hasta 4 kW) y 400/690 V 50 Hz (potencias superiores a 4 kW).
- Temperatura máxima del aire a transportar: Servicio S1 -20 °C +250 °C en continuo. Servicio S2 300 °C/2h y 400 °C/2h.

Variador electrónico de velocidad:

- Velocidad ajustable mediante señal 0-10 V o control automático PI integrado en el variador.

- Variador electrónico altamente configurable con 2 entradas analógicas, 2 entradas digitales, 1 salida de relé y 1 salida analógica o digital a seleccionar.
- Posibilidad de conexión a buses de campo MODBUS y CAN Open.
- Variador electrónico de fácil instalación fuera de la zona de trabajo. Gracias a su carril DIN puede montarse en cuadros de control minimizando las conexiones.
- Se suministra precableado con cable apantallado de acuerdo con la directiva EMC 2014/30/UE.
- Disponibles con entrada monofásica 220-240 V 50/60 Hz hasta 3 CV (Tipo VSD1/A-RFM) o trifásica 380-415 V 50/60 Hz (Tipo VSD3/A-RFT). Protección estándar IP20. Protección IP66 hasta 10 CV bajo pedido.
- Temperatura de trabajo (VSD): -25 °C +50 °C.

Acabado:

- Anticorrosivo en resina de poliéster polimerizada a 190 °C, previo desengrase con tratamiento nanotecnológico libre de fosfatos.

Código de pedido ventilador

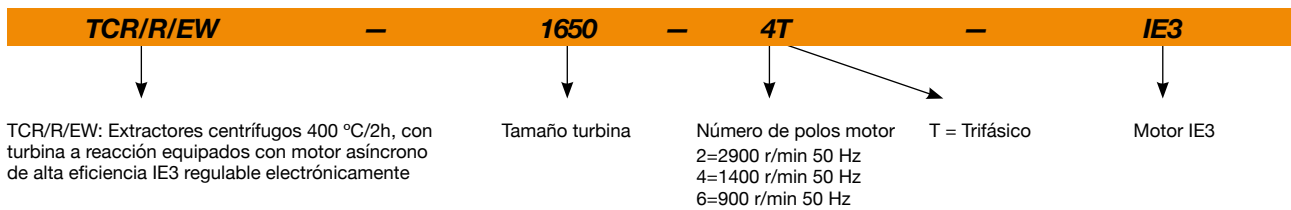

Código de pedido con suministro de variador electrónico (VSD) incluido

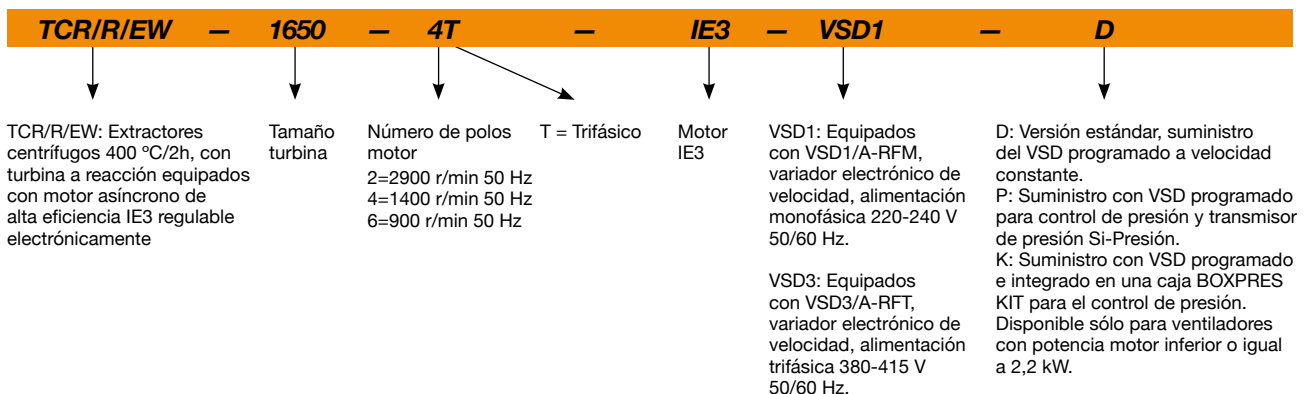

Características técnicas

Modelo	Velocidad mín/máx (r/min)	VSD Monofásico 230 V 50/60 Hz		VSD Trifásico 400 V 50/60 Hz		Intensidad máxima motor 50 Hz (A)			Potencia instalada (kW)	Caudal mín/máx (m³/h)	Nivel presión sonora mín/máx dB (A)	Peso aprox. (Kg)
		Intensidad máxima entrada (A)	Modelo VSD	Intensidad máxima entrada (A)	Modelo VSD	230V	400V	690V				
TCR/R/EW-1240-2T-IE3	1160/2900	-	-	9,44	VSD3/A-RFT-5.5	13,00	7,50	-	4,00	4440 / 11110	62/82	93
TCR/R/EW-1240-4T-IE3	570/1420	8,32	VSD1/A-RFM-1	2,31	VSD3/A-RFT-1	2,82	1,62	-	0,75	2330 / 5830	47/67	71
TCR/R/EW-1445-2T-IE3	1170/2935	-	-	17,45	VSD3/A-RFT-10	-	13,90	8,06	7,50	6620 / 16560	65/85	126
TCR/R/EW-1445-4T-IE3	580/1455	11,87	VSD1/A-RFM-2	3,30	VSD3/A-RFT-2	4,07	2,34	-	1,10	3240 / 8100	50/70	93
TCR/R/EW-1650-4T-IE3	580/1440	15,78	VSD1/A-RFM-1	4,38	VSD3/A-RFT-2	5,41	3,11	-	1,50	4240 / 10600	52/72	114
TCR/R/EW-1650-6T-IE3	380/940	8,69	VSD1/A-RFM-1	2,41	VSD3/A-RFT-1	3,36	1,93	-	0,75	2980 / 7450	42/62	111
TCR/R/EW-1856-4T-IE3	580/1440	-	-	7,20	VSD3/A-RFT-5.5	10,70	6,15	-	3,00	6100 / 15240	58/78	152
TCR/R/EW-1856-6T-IE3	380/945	12,43	VSD1/A-RFM-2	3,45	VSD3/A-RFT-2	4,68	2,69	-	1,10	4020 / 10040	50/70	145
TCR/R/EW-2063-4T-IE3	590/1465	-	-	12,81	VSD3/A-RFT-7.5	-	10,30	5,97	5,50	9800 / 24490	60/80	225
TCR/R/EW-2063-6T-IE3	380/950	16,64	VSD1/A-RFM-2	4,62	VSD3/A-RFT-2	6,43	3,70	-	1,50	6460 / 16140	50/70	209
TCR/R/EW-2271-4T-IE3	590/1470	-	-	25,10	VSD3/A-RFT-15	-	21,40	12,40	11,00	13900 / 34760	62/82	315
TCR/R/EW-2271-6T-IE3	390/970	-	-	7,39	VSD3/A-RFT-5.5	12,00	6,91	-	3,00	9200 / 23000	57/77	280



Erp. (Energy Related Products)

Información de la Directiva 2009/125/EC descargable desde la web de SODECA o programa de selección QuickFan

Características acústicas

Los valores indicados, se determinan mediante medidas de nivel de presión y potencia sonora en dB(A) obtenidas en campo libre a una distancia equivalente a dos veces la envergadura del ventilador más el diámetro de la turbina, con un mínimo de 1,5 m.

Espectro de potencia sonora Lw(A) en dB(A) por banda de frecuencia en Hz

	63	125	250	500	1000	2000	4000	8000		63	125	250	500	1000	2000	4000	8000
TCR/R/EW-1240-2T	68	83	81	93	90	94	96	83	TCR/R/EW-1856-4T	69	78	91	87	90	91	85	71
TCR/R/EW-1240-4T	56	40	76	79	79	80	70	59	TCR/R/EW-1856-6T	61	69	81	83	80	81	71	60
TCR/R/EW-1445-2T	73	85	83	95	93	97	99	89	TCR/R/EW-2063-4T	80	85	91	93	91	88	81	73
TCR/R/EW-1445-4T	59	72	78	83	80	83	78	64	TCR/R/EW-2063-6T	69	70	82	82	81	83	73	63
TCR/R/EW-1650-4T	64	74	82	84	83	85	76	66	TCR/R/EW-2271-4T	79	80	89	92	94	95	91	78
TCR/R/EW-1650-6T	53	65	72	77	73	69	62	54	TCR/R/EW-2271-6T	73	73	87	86	90	90	79	68

Orientaciones

Suministro standard LG 270

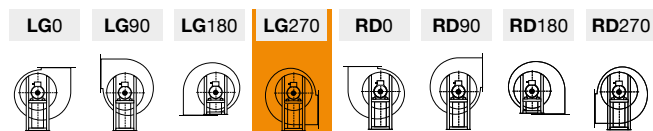

Dimensiones mm

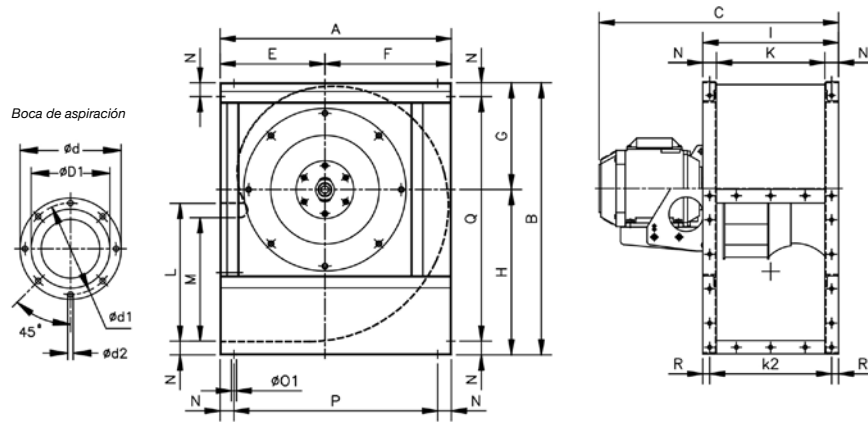

	A	B	C	Ød	Ød1	ØD1*	Ød2	E	F	G	H	I	K	k2	L	M	N	Ø01	P	Q	R
TCR/R/EW-1240-2T	673	790	734	472	444	319	M8	305	368	310	480	395	315	355	400	358,5	40	11	593	710	20
TCR/R/EW-1240-4T	673	790	634	472	444	319	M8	305	368	310	480	395	315	355	400	358,5	40	11	593	710	20
TCR/R/EW-1445-2T	765	880	827	524	494	358	M10	350	415	340	540	445	355	405	450	407	45	11	675	790	20
TCR/R/EW-1445-4T	765	880	699	524	494	358	M10	350	415	340	540	445	355	405	450	407	45	11	675	790	20
TCR/R/EW-1650-4T	832	970	953	582	555	401	M10	375	457	378	592	490	400	450	500	446	45	13	742	880	20
TCR/R/EW-1650-6T	832	970	772,5	582	555	401	M10	375	457	378	592	490	400	450	500	446	45	13	742	880	20
TCR/R/EW-1856-4T	925	1084	880	645	615	457	M10	415	510	426	658	550	450	500	560	493	50	13	825	984	25
TCR/R/EW-1856-6T	925	1084	825	645	615	457	M10	415	510	426	658	550	450	500	560	493	50	13	825	984	25
TCR/R/EW-2063-4T	1037	1218	981	720	688	507	M10	465	572	477	741	620	500	560	630	530	60	13	917	1098	30
TCR/R/EW-2063-6T	1037	1218	932	720	688	507	M10	465	572	477	741	620	500	560	630	530	60	13	917	1098	30
TCR/R/EW-2271-4T	1173	1375	1197	800	768	575	M10	525	648	538	837	690	560	625	710	603,5	65	13	1043	1245	32,5
TCR/R/EW-2271-6T	1173	1375	1095	800	768	575	M10	525	648	538	837	690	560	625	710	603,5	65	13	1043	1245	32,5

* Diámetro nominal tubería recomendada

Boca de impulsión

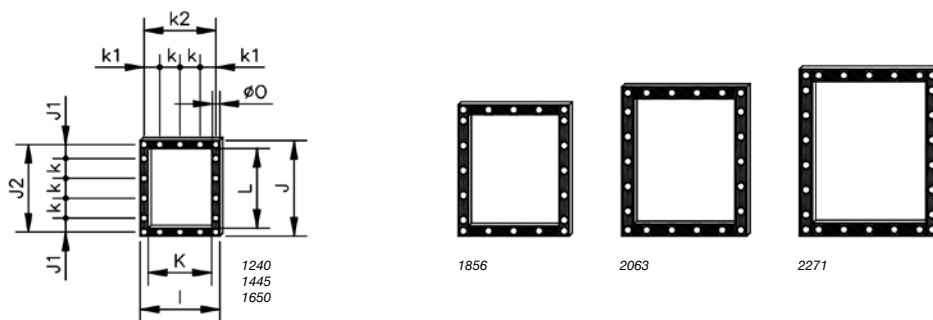

	I	J	J1	J2	K	k3	k1	k2	L	Ø0
TCR/R/EW-1240	395	480	70	440	315	100	77,5	355	400	13
TCR/R/EW-1445	445	540	99	498	355	100	102,5	405	450	11
TCR/R/EW-1650	490	590	87,5	550	400	125	100	450	500	13
TCR/R/EW-1856	550	660	55	610	450	125	125	500	560	13
TCR/R/EW-2063	620	750	95	690	500	125	92,5	560	630	13
TCR/R/EW-2271	690	840	75	778	560	125	62,5	625	710	13

Curvas características

Q= Caudal en m³/h, m³/s y cfm

Pe= Presión estática en mmH₂O, Pa e inwg

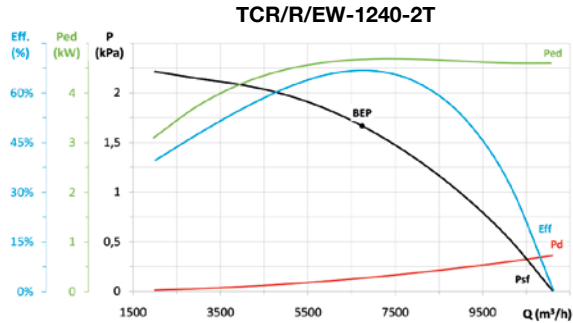

MC	EC	SR	Cc	η_e (%)*	N	[kW]	[m ³ /h]	[Pa]	[rpm]	VSD
A	S	1,02	1,04	69,6%	73,1	4,675	6744	1667,2	2901	NECESSARY

* η_e (%) = Eff. (%) x Cc

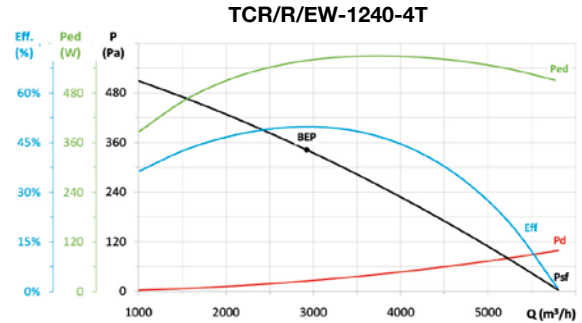

MC	EC	SR	Cc	η_e (%)*	N	[kW]	[m ³ /h]	[Pa]	[rpm]	VSD
A	S	1,00	1,11	55,1%	68,2	0,558	2924	342,3	1453	NECESSARY

* η_e (%) = Eff. (%) x Cc

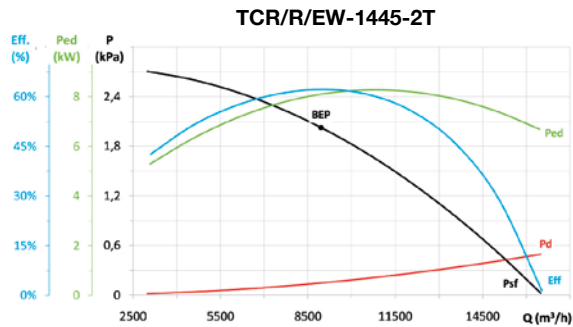

MC	EC	SR	Cc	η_e (%)*	N	[kW]	[m ³ /h]	[Pa]	[rpm]	VSD
A	S	1,02	1,04	64,6%	65,6	8,103	8951	2025,7	2939	NECESSARY

* η_e (%) = Eff. (%) x Cc

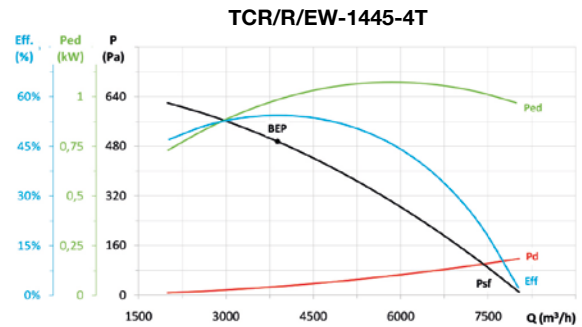

MC	EC	SR	Cc	η_e (%)*	N	[kW]	[m ³ /h]	[Pa]	[rpm]	VSD
A	S	1,01	1,09	59,1%	69,7	0,983	3883	495,3	1468	NECESSARY

* η_e (%) = Eff. (%) x Cc

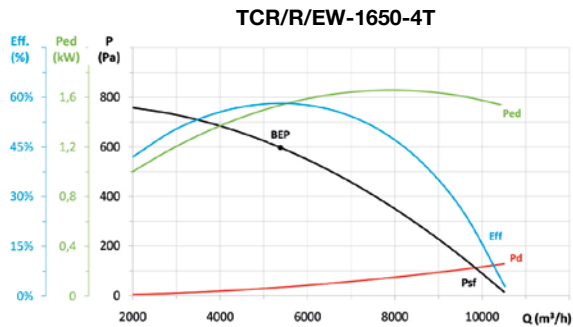

MC	EC	SR	Cc	η_e (%)*	N	[kW]	[m ³ /h]	[Pa]	[rpm]	VSD
A	S	1,01	1,08	62,5%	71,1	1,535	5378	597,4	1449	NECESSARY

* η_e (%) = Eff. (%) x Cc

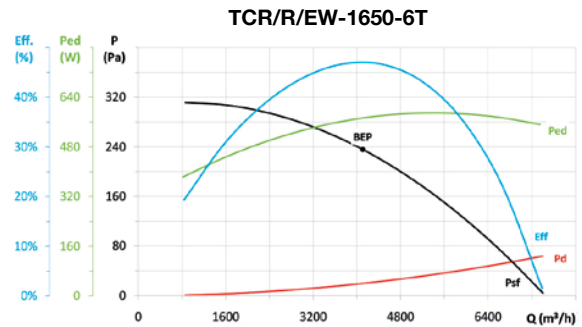

MC	EC	SR	Cc	η_e (%)*	N	[kW]	[m ³ /h]	[Pa]	[rpm]	VSD
A	S	1,00	1,10	52,0%	65,0	0,572	4109	235,7	966	NECESSARY

* η_e (%) = Eff. (%) x Cc

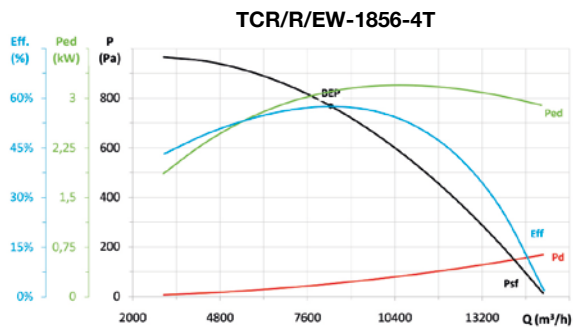

MC	EC	SR	Cc	η_e (%)*	N	[kW]	[m ³ /h]	[Pa]	[rpm]	VSD
A	S	1,01	1,05	60,6%	65,9	3,096	8342	768,0	1448	NECESSARY

* η_e (%) = Eff. (%) x Cc

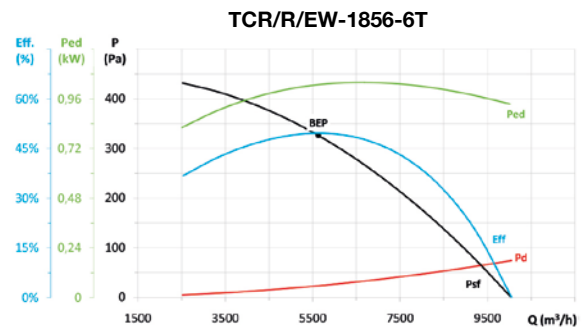

MC	EC	SR	Cc	η_e (%)*	N	[kW]	[m ³ /h]	[Pa]	[rpm]	VSD
A	S	1,00	1,09	53,9%	64,3	1,028	5632	326,1	960	NECESSARY

* η_e (%) = Eff. (%) x Cc

Curvas características

Q= Caudal en m³/h, m³/s y cfm

Pe= Presión estática en mmH₂O, Pa e inwg

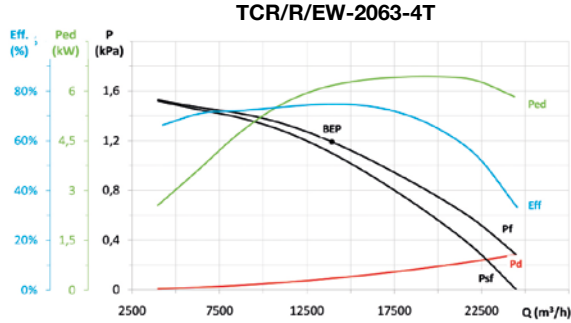

MC	EC	SR	Cc	η_e (%)*	N	[kW]	[m³/h]	[Pa]	[rpm]	VSD
B	T	1,01	1,04	77,8%	80,0	6,161	13932	1390,7	1466	NECESSARY

* η_e (%) = Eff. (%) x Cc

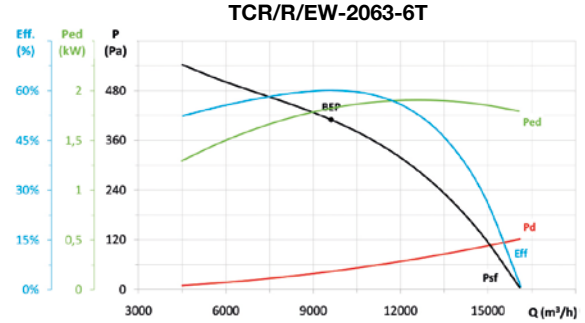

MC	EC	SR	Cc	η_e (%)*	N	[kW]	[m³/h]	[Pa]	[rpm]	VSD
A	S	1,00	1,07	64,3%	72,1	1,822	9620	409,7	952	NECESSARY

* η_e (%) = Eff. (%) x Cc

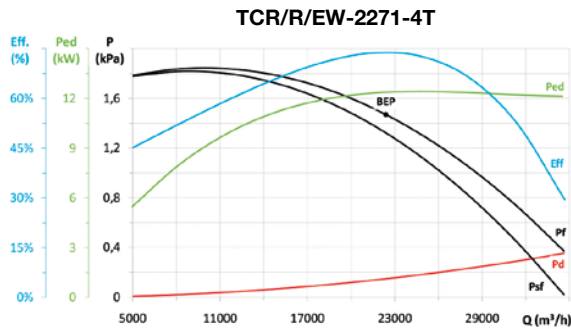

MC	EC	SR	Cc	η_e (%)*	N	[kW]	[m³/h]	[Pa]	[rpm]	VSD
B	T	1,01	1,04	76,8%	76,7	12,369	22380	1469,6	1470	NECESSARY

* η_e (%) = Eff. (%) x Cc

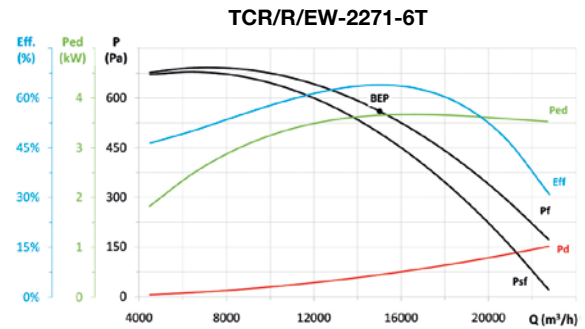

MC	EC	SR	Cc	η_e (%)*	N	[kW]	[m³/h]	[Pa]	[rpm]	VSD
B	T	1,01	1,05	67,1%	71,7	3,654	15016	560,2	970	NECESSARY

* η_e (%) = Eff. (%) x Cc

Accesorios



CJTCR/R

Unidades de extracción 400 °C/2h, con turbina a reacción



Turbina a reacción de alto rendimiento, y gran robustez

Unidades de extracción 400 °C/2h con caja aislada acústicamente, para trabajar en el exterior de la zona de riesgo de incendios, de simple aspiración y gran robustez.

Ventilador:

- Envoltente en chapa de acero.
- Turbina a reacción en chapa de acero de gran robustez, con pintura anticorrosiva.
- Homologación según norma EN 12101-3, con certificación n°: 0370-CPR-0401.

Motor:

- Motores clase F con rodamientos a bolas y protección IP55.
- Motores con eficiencia IE3 para potencias iguales o superiores a 0,75 kW, excepto monofásicos, 2 velocidades y 8 polos.

- Trifásico 230/400 V 50 Hz (hasta 4 kW) y 400/690 V 50 Hz (potencias superiores a 4 kW).
- Temperatura máxima del aire a transportar: Servicio S1 -20 °C +250 °C en continuo. Servicio S2 300 °C/2h y 400 °C/2h.

Acabado:

- Anticorrosivo en chapa de acero galvanizado.

Bajo demanda:

- Extractores con motor de 2 velocidades.
- Extractores a transmisión.

Código de pedido

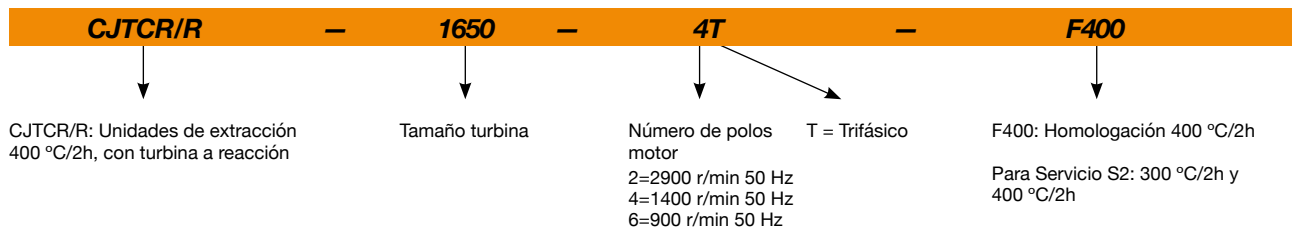

Características técnicas

Modelo	Velocidad (r/min)	Intensidad máxima admisible (A)			Potencia instalada (kW)	Caudal máximo (m³/h)	Nivel presión sonora dB (A)	Peso aprox. (Kg)
		230V	400V	690V				
CJTCR/R-1240-2T IE3	2900	13,00	7,50		4,00	11110	77	156
CJTCR/R-1240-4T IE3	1420	2,82	1,62		0,75	5830	62	126
CJTCR/R-1445-2T IE3	2930		14,10	8,17	7,50	16560	80	206
CJTCR/R-1445-4T IE3	1455	4,07	2,34		1,10	8100	65	181
CJTCR/R-1650-4T IE3	1440	5,41	3,11		1,50	10600	66	197
CJTCR/R-1650-6T IE3	940	3,36	1,93		0,75	7450	57	189
CJTCR/R-1856-4T IE3	1440	10,70	6,15		3,00	15240	73	278
CJTCR/R-1856-6T IE3	945	4,68	2,69		1,10	10040	65	272
CJTCR/R-2063-4T IE3	1465		10,30	5,97	5,50	24490	75	403
CJTCR/R-2063-6T IE3	950	6,43	3,70		1,50	16140	65	368
CJTCR/R-2271-4T IE3	1470		20,90	12,10	11,00	34760	82	533
CJTCR/R-2271-6T IE3	970	12,00	6,91		3,00	23000	72	473

Características acústicas

Los valores indicados, se determinan mediante medidas de nivel de presión y potencia sonora en dB(A) obtenidas en campo libre a una distancia equivalente a dos veces la envergadura del ventilador más el diámetro de la turbina, con un mínimo de 1,5 m.

Espectro de potencia sonora Lw(A) en dB(A) por banda de frecuencia en Hz

	63	125	250	500	1000	2000	4000	8000		63	125	250	500	1000	2000	4000	8000
CJTCR/R-1240-2T	63	78	76	88	85	89	91	78	CJTCR/R-1856-4T	64	73	86	82	85	86	80	66
CJTCR/R-1240-4T	51	65	71	74	74	75	65	54	CJTCR/R-1856-6T	56	64	76	78	75	76	66	55
CJTCR/R-1445-2T	68	80	78	90	88	92	94	84	CJTCR/R-2063-4T	75	80	86	88	86	83	76	68
CJTCR/R-1445-4T	54	67	73	78	75	78	73	59	CJTCR/R-2063-6T	64	65	77	77	76	78	68	58
CJTCR/R-1650-4T	58	68	76	78	77	79	70	60	CJTCR/R-2271-4T	79	80	89	92	94	95	91	78
CJTCR/R-1650-6T	48	60	67	72	68	64	57	49	CJTCR/R-2271-6T	68	68	82	81	85	85	74	63

Orientaciones

Suministro standard LG 270

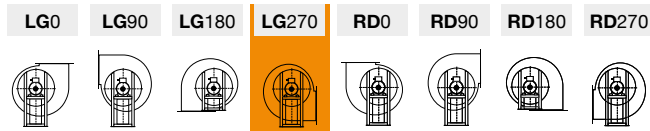

Dimensiones mm

Suministro standard: LG 270

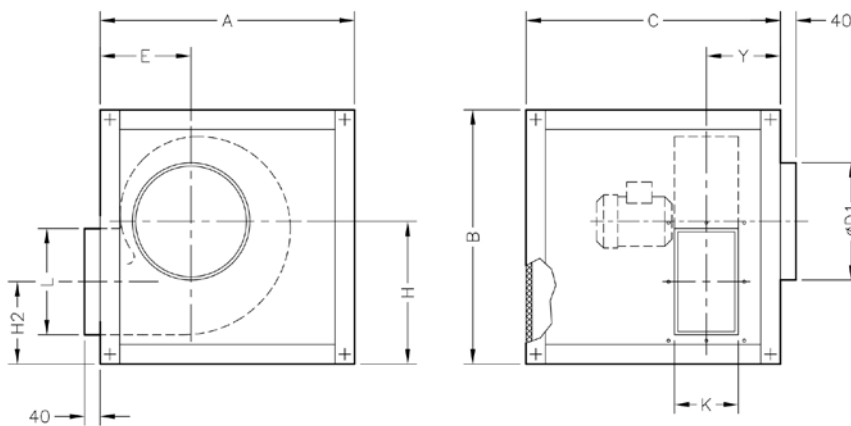

	A	B	C	ØD1	E	H	H2	K	L	Y
CJTCR/R-1240	970	970	970	400	312	549	308	315	400	307,5
CJTCR/R-1445	1070	1070	1070	450	357	610	339	355	450	333,5
CJTCR/R-1650	1160	1160	1160	500	382	660	365	400	500	355
CJTCR/R-1856	1260	1260	1050	560	422	727	399	450	560	360
CJTCR/R-2063	1400	1400	1200	630	472	810	444	500	630	395
CJTCR/R-2271	1555	1555	1355	710	532	906	489	560	715	430

Dimensiones mm

Suministro bajo demanda: LG 90

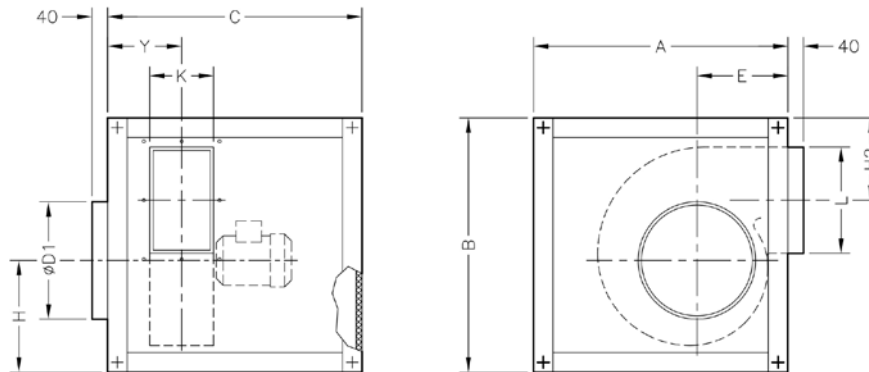

	A	B	C	ØD1	E	H	H2	K	L	Y
CJTCR/R-1240	970	970	970	400	312	379	350	315	400	307,5
CJTCR/R-1445	1070	1070	1070	450	357	408	391	355	450	333,5
CJTCR/R-1650	1160	1160	1160	500	382	447	419	400	500	355
CJTCR/R-1856	1260	1260	1050	560	422	495	438	450	560	360
CJTCR/R-2063	1400	1400	1200	630	472	546	488	500	630	395
CJTCR/R-2271	1555	1555	1355	710	532	607	532	560	715	430

Suministro bajo demanda: LG 0

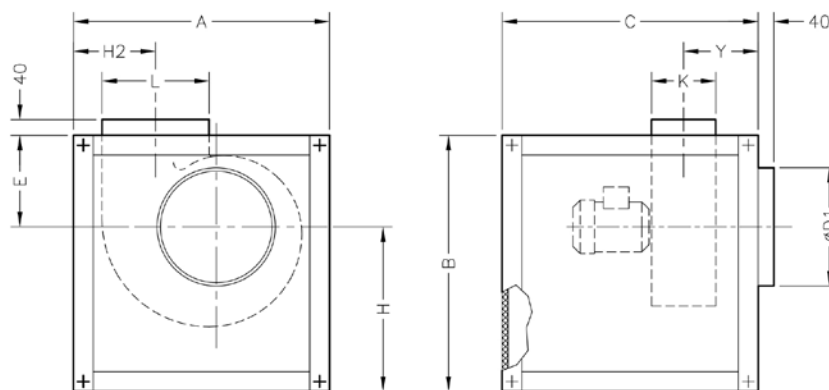

	A	B	C	ØD1	E	H	H2	K	L	Y
CJTCR/R-1240	970	970	970	400	533	437	322	315	400	307,5
CJTCR/R-1445	1070	1070	1070	450	586	484	367	355	450	333,5
CJTCR/R-1650	1160	1160	1160	500	634,5	525,5	391,5	400	500	355
CJTCR/R-1856	1260	1260	1050	560	681,5	578,5	442,5	450	560	360
CJTCR/R-2063	1400	1400	1200	630	759	641	482	500	630	395
CJTCR/R-2271	1555	1555	1355	710	838	717	518,5	560	715	430

Dimensiones mm

Boca de impulsión

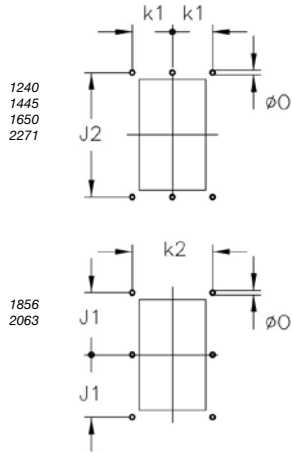

	k1	k2	J1	J2	ØO
CJTCR/R-1240	177,5	-	-	440	11
CJTCR/R-1445	202,5	-	-	498	11
CJTCR/R-1650	225	-	-	550	13
CJTCR/R-1856	-	500	305	-	13
CJTCR/R-2063	-	560	345	-	13
CJTCR/R-2271	312,5	-	-	775	13

Accesorios



INT



IAT



CABLE BOX



C2V



VSD3/A-RFT
- VSD1/A-RFM



CENTRAL CO



AET



RPA



B



BD



BIC



VIS



ACE ACE/400



TEJ

Curvas características

Q= Caudal en m³/h, m³/s y cfm

Pe= Presión estática en mmH₂O, Pa e in wg

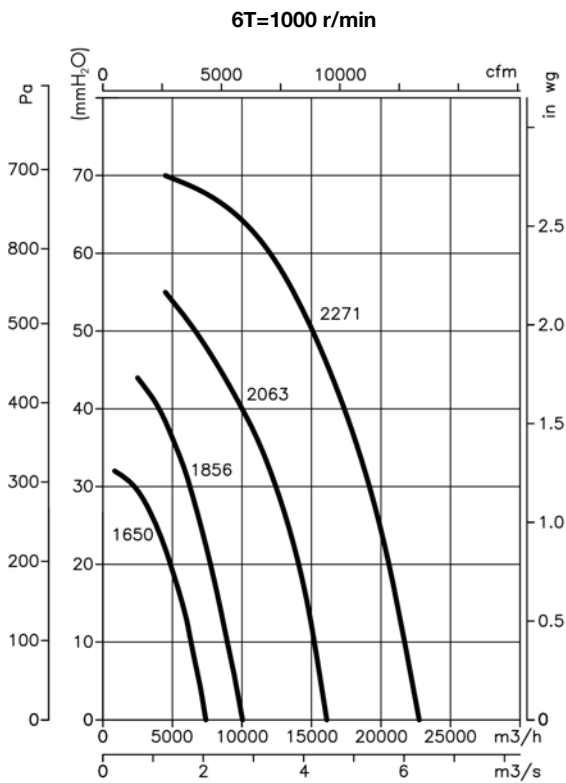
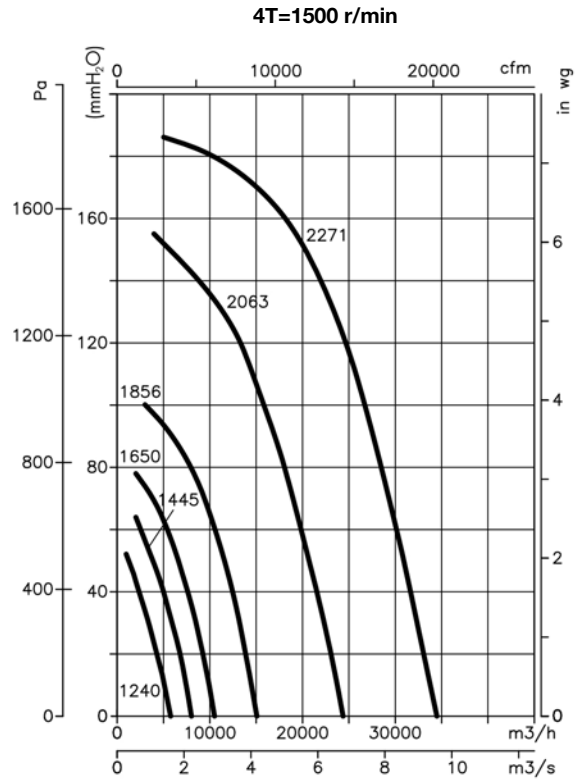
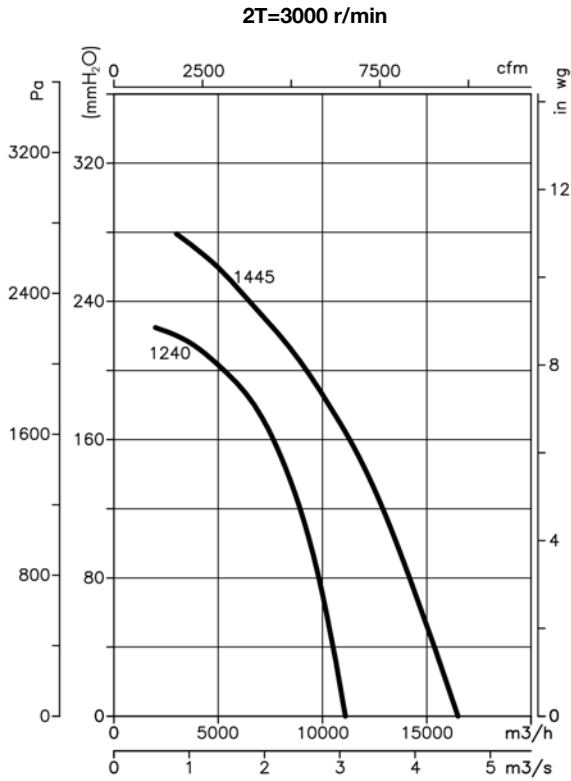

CJTCR/R/EW



Unidades de extracción 400 °C/2h, con turbina a reacción equipados con motor asíncrono de alta eficiencia IE3 regulable electrónicamente



VARIADOR VELOCIDAD
VSD: Variador electrónico de velocidad.
· VSD1/A-RFM
· VSD3/A-RFT
Suministro según pedido

CONTROL
Suministro como accesorio opcional

ALIMENTACIÓN
VSD1/A-RFM:
220-240 V 50/60 Hz
VSD3/A-RFT:
380-415 V 50/60 Hz

Unidades de extracción 400 °C/2h con caja aislada acústicamente, para trabajar en el exterior de la zona de riesgo de incendios, de simple aspiración y gran robustez. Equipados con motor asíncrono de alta eficiencia IE3 regulable electrónicamente.

Ventilador:

- Envoltorio en chapa de acero.
- Turbina a reacción en chapa de acero de gran robustez, con pintura anticorrosiva.
- Homologación según norma EN 12101-3.

Motor:

- Nuevos motores AC asíncronos de alta eficiencia (IE3).
- Equipados con rodamientos a bolas de larga duración. Protección IP55.
- Trifásico 230/400 V 50 Hz (hasta 4 kW) y 400/690 V 50 Hz (potencias superiores a 4 kW).
- Temperatura máxima del aire a transportar: Servicio S1 -20 °C +250 °C en continuo. Servicio S2 300 °C/2h y 400 °C/2h.

Variador electrónico de velocidad:

- Velocidad ajustable mediante señal 0-10 V o control automático PI integrado en el variador.
- Variador electrónico altamente configurable con 2 entradas analógicas, 2 entradas digitales, 1 salida de relé y 1 salida analógica o digital a seleccionar.
- Posibilidad de conexión a buses de campo MODBUS y CAN Open.
- Variador electrónico de fácil instalación fuera de la zona de trabajo. Gracias a su carril DIN puede montarse en cuadros de control minimizando las conexiones.
- Se suministra precableado con cable apantallado de acuerdo con la directiva EMC 2014/30/UE.
- Disponibles con entrada monofásica 220-240 V 50/60 Hz hasta 3 CV (Tipo VSD1/A-RFM) o trifásica 380-415 V 50/60 Hz (Tipo VSD3/A-RFT). Protección estándar IP20. Protección IP66 hasta 10 CV bajo pedido.
- Temperatura de trabajo (VSD): -25 °C +50 °C.

Acabado:

- Anticorrosivo en chapa de acero galvanizado.

Código de pedido ventilador

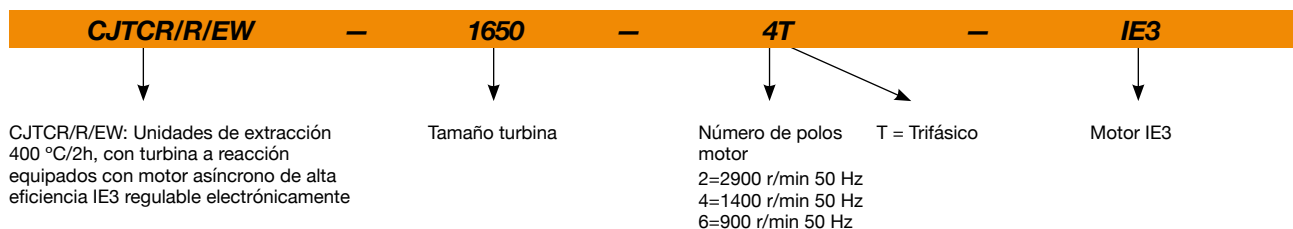

Código de pedido con suministro de variador electrónico (VSD) incluido

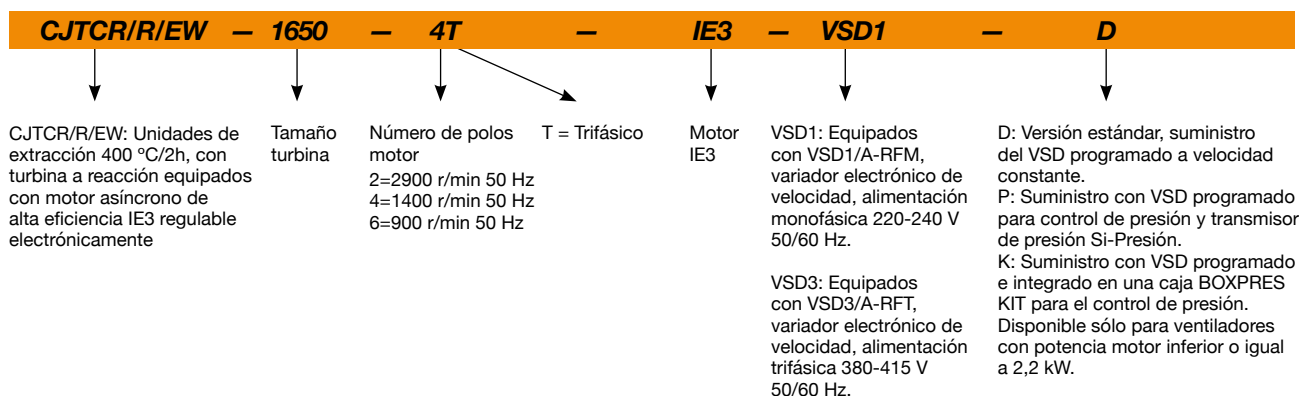

Características técnicas

Modelo	Velocidad mín/máx (r/min)	VSD Monofásico 230 V 50/60 Hz		VSD Trifásico 400 V 50/60 Hz		Intensidad máxima motor 50 Hz (A)			Potencia instalada (kW)	Caudal mín/máx (m³/h)	Nivel presión sonora mín/máx dB (A)	Peso aprox. (Kg)
		Intensidad máxima entrada (A)	Modelo VSD	Intensidad máxima entrada (A)	Modelo VSD	230V	400V	690V				
CJTCR/R/EW-1240-2T-IE3	1160/2900	-	-	9,44	VSD3/A-RFT-5.5	13,00	7,50	-	4,00	4440 / 11110	57/77	147
CJTCR/R/EW-1240-4T-IE3	570/1420	8,32	VSD1/A-RFM-1	2,31	VSD3/A-RFT-1	2,82	1,62	-	0,75	2330 / 5830	42/62	125
CJTCR/R/EW-1445-2T-IE3	1170/2935	-	-	17,45	VSD3/A-RFT-10	-	13,90	8,06	7,50	6620 / 16560	60/80	210
CJTCR/R/EW-1445-4T-IE3	580/1455	11,87	VSD1/A-RFM-2	3,30	VSD3/A-RFT-2	4,07	2,34	-	1,10	3240 / 8100	45/65	177
CJTCR/R/EW-1650-4T-IE3	580/1440	15,78	VSD1/A-RFM-2	4,38	VSD3/A-RFT-2	5,41	3,11	-	1,50	4240 / 10600	46/66	189
CJTCR/R/EW-1650-6T-IE3	380/940	8,69	VSD1/A-RFM-1	2,41	VSD3/A-RFT-1	3,36	1,93	-	0,75	2980 / 7450	37/57	186
CJTCR/R/EW-1856-4T-IE3	580/1440	-	-	7,20	VSD3/A-RFT-5.5	10,70	6,15	-	3,00	6100 / 15240	53/73	273
CJTCR/R/EW-1856-6T-IE3	380/945	12,43	VSD1/A-RFM-2	3,45	VSD3/A-RFT-2	4,68	2,69	-	1,10	4020 / 10040	45/65	266
CJTCR/R/EW-2063-4T-IE3	590/1465	-	-	12,81	VSD3/A-RFT-7.5	-	10,30	5,97	5,50	9800 / 24490	55/75	380
CJTCR/R/EW-2063-6T-IE3	380/950	16,64	VSD1/A-RFM-2	4,62	VSD3/A-RFT-2	6,43	3,70	-	1,50	6460 / 16140	45/65	364
CJTCR/R/EW-2271-4T-IE3	590/1470	-	-	25,10	VSD3/A-RFT-15	-	21,40	12,40	11,00	13900 / 34760	62/82	508
CJTCR/R/EW-2271-6T-IE3	390/970	-	-	7,39	VSD3/A-RFT-5.5	12,00	6,91	-	3,00	9200 / 23000	52/72	473



Erp. (Energy Related Products)

Información de la Directiva 2009/125/EC descargable desde la web de SODECA o programa de selección QuickFan

Características acústicas

Los valores indicados, se determinan mediante medidas de nivel de presión y potencia sonora en dB(A) obtenidas en campo libre a una distancia equivalente a dos veces la envergadura del ventilador más el diámetro de la turbina, con un mínimo de 1,5 m.

Espectro de potencia sonora Lw(A) en dB(A) por banda de frecuencia en Hz

	63	125	250	500	1000	2000	4000	8000		63	125	250	500	1000	2000	4000	8000
CJTCR/R/EW-1240-2T	63	78	76	88	85	89	91	78	CJTCR/R/EW-1856-4T	64	73	86	82	85	86	80	66
CJTCR/R/EW-1240-4T	51	65	71	74	74	75	65	54	CJTCR/R/EW-1856-6T	56	64	76	78	75	76	66	55
CJTCR/R/EW-1445-2T	68	80	78	90	88	92	94	84	CJTCR/R/EW-2063-4T	75	80	86	88	86	83	76	68
CJTCR/R/EW-1445-4T	54	67	73	78	75	78	73	59	CJTCR/R/EW-2063-6T	64	65	77	77	76	78	68	58
CJTCR/R/EW-1650-4T	58	68	76	78	77	79	70	60	CJTCR/R/EW-2271-4T	79	80	89	92	94	95	91	78
CJTCR/R/EW-1650-6T	48	60	67	72	68	64	57	49	CJTCR/R/EW-2271-6T	68	68	82	81	85	85	74	63

Orientaciones

Suministro standard LG 270

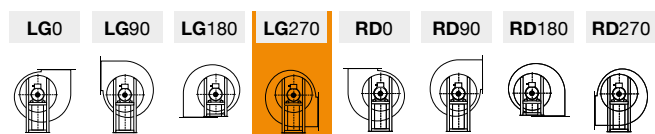

Dimensiones mm

Suministro standard: LG 270

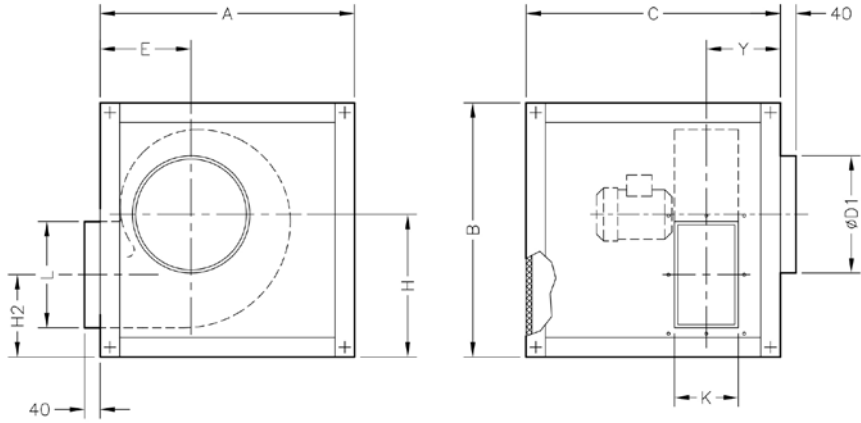

	A	B	C	ØD1	E	H	H2	K	L	Y
CJTCR/R/EW-1240	970	970	970	400	312	549	308	315	400	307,5
CJTCR/R/EW-1445	1070	1070	1070	450	357	610	339	355	450	333,5
CJTCR/R/EW-1650	1160	1160	1160	500	382	660	365	400	500	355
CJTCR/R/EW-1856	1260	1260	1050	560	422	727	399	450	560	360
CJTCR/R/EW-2063	1400	1400	1200	630	472	810	444	500	630	395
CJTCR/R/EW-2271	1555	1555	1355	710	532	906	489	560	715	430

Suministro bajo demanda: LG 90

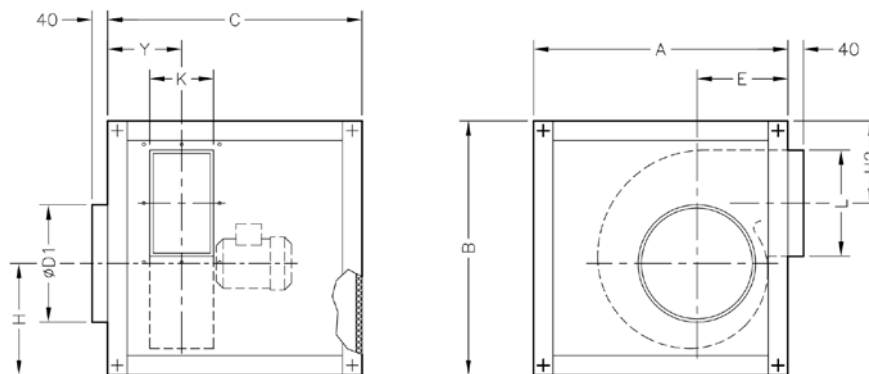

	A	B	C	ØD1	E	H	H2	K	L	Y
CJTCR/R/EW-1240	970	970	970	400	312	379	350	315	400	307,5
CJTCR/R/EW-1445	1070	1070	1070	450	357	408	391	355	450	333,5
CJTCR/R/EW-1650	1160	1160	1160	500	382	447	419	400	500	355
CJTCR/R/EW-1856	1260	1260	1050	560	422	495	438	450	560	360
CJTCR/R/EW-2063	1400	1400	1200	630	472	546	488	500	630	395
CJTCR/R/EW-2271	1555	1555	1355	710	532	607	532	560	715	430

Dimensiones mm

Suministro bajo demanda: LG 0

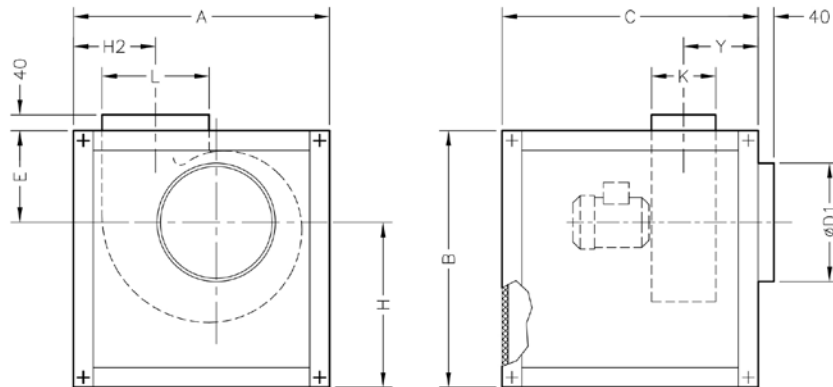

	A	B	C	ØD1	E	H	H2	K	L	Y
CJTCR/R/EW-1240	970	970	970	400	533	437	322	315	400	307,5
CJTCR/R/EW-1445	1070	1070	1070	450	586	484	367	355	450	333,5
CJTCR/R/EW-1650	1160	1160	1160	500	634,5	525,5	391,5	400	500	355
CJTCR/R/EW-1856	1260	1260	1050	560	681,5	578,5	442,5	450	560	360
CJTCR/R/EW-2063	1400	1400	1200	630	759	641	482	500	630	395
CJTCR/R/EW-2271	1555	1555	1355	710	838	717	518,5	560	715	430

Boca de impulsión

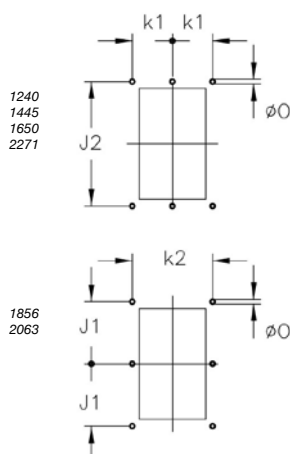

	k1	k2	J1	J2	ØO
CJTCR/R/EW-1240	177,5	-	-	440	11
CJTCR/R/EW-1445	202,5	-	-	498	11
CJTCR/R/EW-1650	225	-	-	550	13
CJTCR/R/EW-1856	-	500	305	-	13
CJTCR/R/EW-2063	-	560	345	-	13
CJTCR/R/EW-2271	312,5	-	-	775	13

Curvas características

Q= Caudal en m³/h, m³/s y cfm

Pe= Presión estática en mmH₂O, Pa e inwg

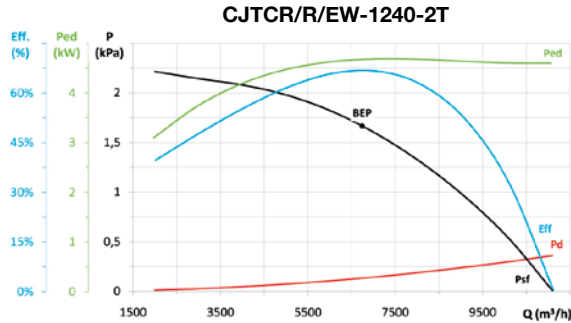

MC	EC	SR	Cc	η_e (%)*	N	[kW]	[m³/h]	[Pa]	[rpm]	VSD
A	S	1,02	1,04	69,6%	73,1	4,675	6744	1667,2	2901	NECESSARY

* η_e (%) = Eff. (%) x Cc

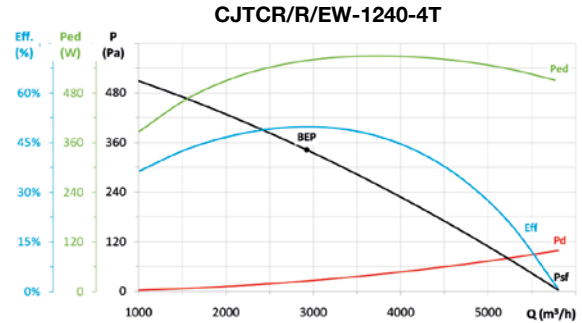

MC	EC	SR	Cc	η_e (%)*	N	[kW]	[m³/h]	[Pa]	[rpm]	VSD
A	S	1,00	1,11	55,1%	68,2	0,558	2924	342,3	1453	NECESSARY

* η_e (%) = Eff. (%) x Cc

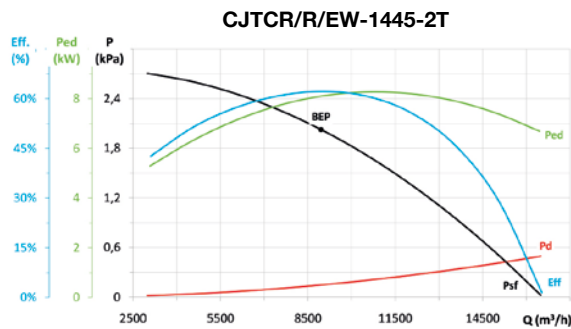

MC	EC	SR	Cc	η_e (%)*	N	[kW]	[m³/h]	[Pa]	[rpm]	VSD
A	S	1,02	1,04	64,6%	65,6	8,103	8951	2025,7	2939	NECESSARY

* η_e (%) = Eff. (%) x Cc

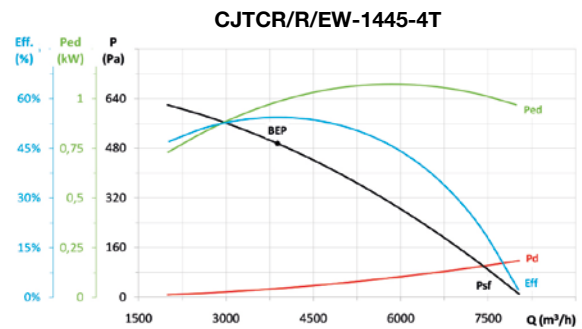

MC	EC	SR	Cc	η_e (%)*	N	[kW]	[m³/h]	[Pa]	[rpm]	VSD
A	S	1,01	1,09	59,1%	69,7	0,983	3883	495,3	1468	NECESSARY

* η_e (%) = Eff. (%) x Cc

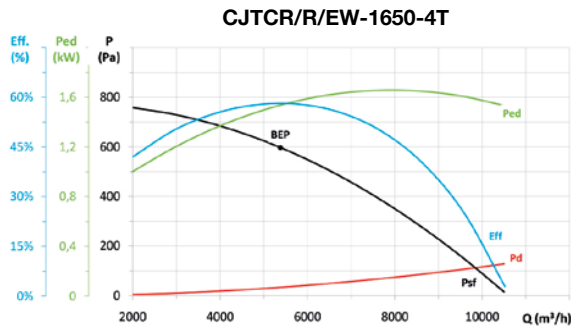

MC	EC	SR	Cc	η_e (%)*	N	[kW]	[m³/h]	[Pa]	[rpm]	VSD
A	S	1,01	1,08	62,5%	71,1	1,535	5378	597,4	1449	NECESSARY

* η_e (%) = Eff. (%) x Cc

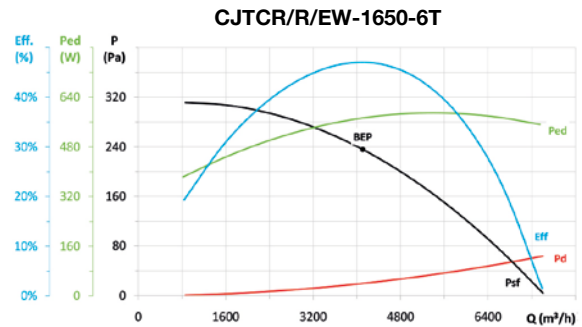

MC	EC	SR	Cc	η_e (%)*	N	[kW]	[m³/h]	[Pa]	[rpm]	VSD
A	S	1,00	1,10	52,0%	65,0	0,572	4109	235,7	966	NECESSARY

* η_e (%) = Eff. (%) x Cc

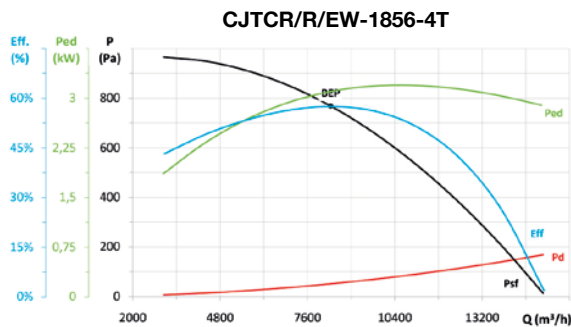

MC	EC	SR	Cc	η_e (%)*	N	[kW]	[m³/h]	[Pa]	[rpm]	VSD
A	S	1,01	1,05	60,6%	65,9	3,096	8342	768,0	1448	NECESSARY

* η_e (%) = Eff. (%) x Cc

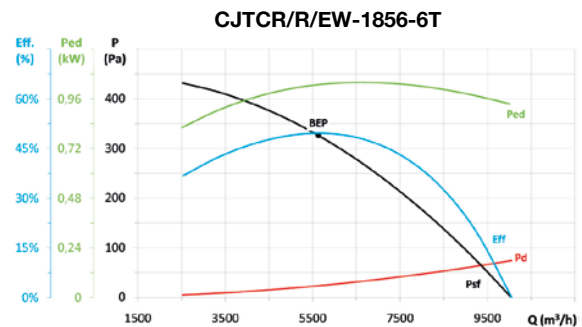

MC	EC	SR	Cc	η_e (%)*	N	[kW]	[m³/h]	[Pa]	[rpm]	VSD
A	S	1,00	1,09	53,9%	64,3	1,028	5632	326,1	960	NECESSARY

* η_e (%) = Eff. (%) x Cc

Curvas características

Q= Caudal en m³/h, m³/s y cfm

Pe= Presión estática en mmH₂O, Pa e inwg

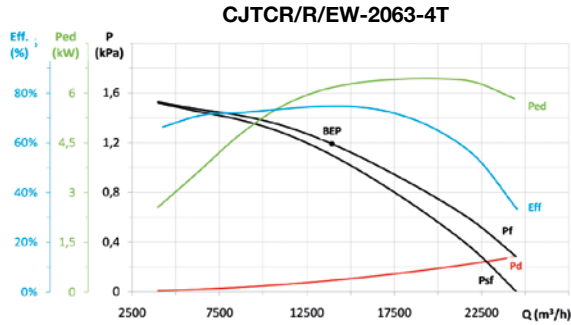

MC	EC	SR	Cc	η_e (%)*	N	[kW]	[m³/h]	[Pa]	[rpm]	VSD
B	T	1,01	1,04	77,8%	80,0	6,161	13932	1190,7	1466	NECESSARY

* η_e (%) = Eff. (%) x Cc

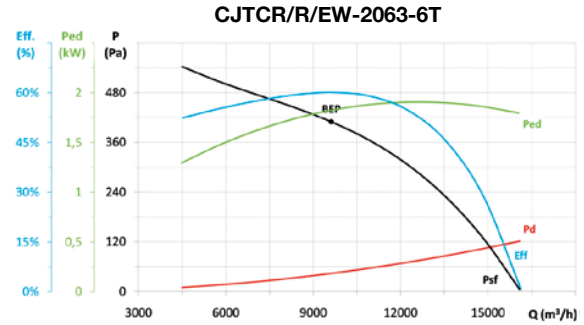

MC	EC	SR	Cc	η_e (%)*	N	[kW]	[m³/h]	[Pa]	[rpm]	VSD
A	S	1,00	1,07	64,3%	72,1	1,822	9620	409,7	952	NECESSARY

* η_e (%) = Eff. (%) x Cc

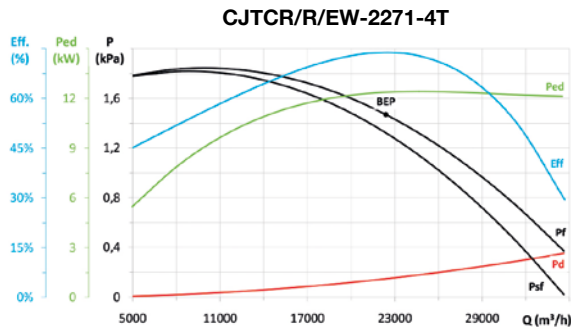

MC	EC	SR	Cc	η_e (%)*	N	[kW]	[m³/h]	[Pa]	[rpm]	VSD
B	T	1,01	1,04	76,8%	76,7	12,369	22380	1469,6	1470	NECESSARY

* η_e (%) = Eff. (%) x Cc

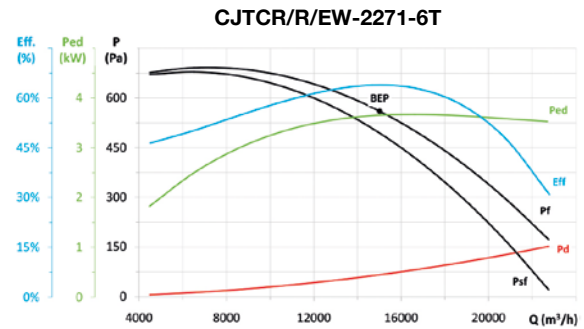

MC	EC	SR	Cc	η_e (%)*	N	[kW]	[m³/h]	[Pa]	[rpm]	VSD
B	T	1,01	1,05	67,1%	71,7	3,654	15016	560,2	970	NECESSARY

* η_e (%) = Eff. (%) x Cc

Accesorios



TCMP

Extractores centrífugos 400 °C/2h, con turbina a acción



Extractores centrífugos 400 °C/2h, para trabajar en el exterior de la zona de riesgo de incendios, de simple aspiración.

Ventilador:

- Envoltente en chapa de acero.
- Turbina a acción en chapa de acero galvanizado.
- Homologación según norma EN 12101-3, con certificación n°: 0370-CPR-0313.

Motor:

- Motores clase F con rodamientos a bolas y protección IP55.
- Motores con eficiencia IE3 para potencias iguales o superiores a 0,75 kW, excepto monofásicos, 2 velocidades y 8 polos.

- Trifásico 230/400 V 50 Hz (hasta 4 kW) y 400/690 V 50 Hz (potencias superiores a 4 kW).
- Temperatura máxima del aire a transportar: Servicio S1 -20 °C +250 °C en continuo. Servicio S2 300 °C/2h y 400 °C/2h.

Acabado:

- Anticorrosivo en resina de poliéster polimerizada a 190 °C, previo desengrase con tratamiento nanotecnológico libre de fosfatos.

Bajo demanda:

- Extractores con motor de 2 velocidades.
- Extractores a transmisión.

Código de pedido

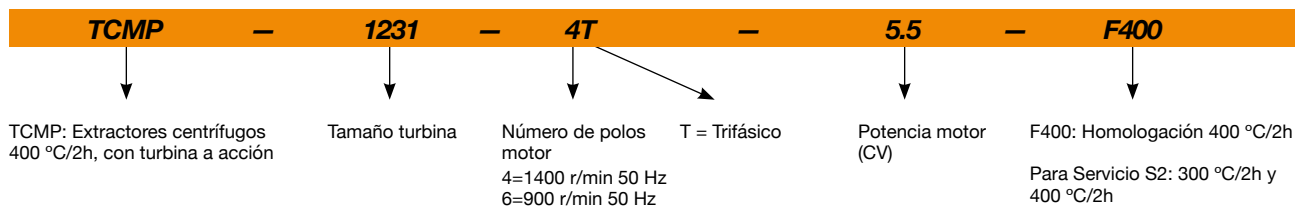

Características técnicas

Modelo	Velocidad (r/min)	Intensidad máxima admisible (A)			Potencia instalada (kW)	Caudal máximo (m³/h)	Nivel presión sonora dB (A)	Peso aprox. (Kg)
		230V	400V	690V				
TCMP-820-4T	1350	1,66	0,96		0,25	1670	58	11
TCMP-922-4T	1380	2,92	1,69		0,55	2450	59	20
TCMP-1025-4T-1.5 IE3	1455	4,07	2,34		1,10	3400	63	28
TCMP-1025-4T-2 IE3	1440	5,41	3,11		1,50	3650	65	31
TCMP-1128-4T-3 IE3	1435	7,93	4,56		2,20	5000	67	38
TCMP-1128-4T-4 IE3	1440	10,70	6,15		3,00	5450	68	41
TCMP-1128-6T IE3	940	3,36	1,93		0,75	3300	53	30
TCMP-1231-4T-3 IE3	1435	7,93	4,56		2,20	4740	68	45
TCMP-1231-4T-4 IE3	1440	10,70	6,15		3,00	5910	70	48
TCMP-1231-4T-5.5 IE3	1450	13,90	8,00		4,00	6850	72	55
TCMP-1231-6T IE3	950	6,43	3,70		1,50	5120	59	45
TCMP-1435-4T-4 IE3	1440	10,70	6,15		3,00	5400	71	55
TCMP-1435-4T-5.5 IE3	1450	13,90	8,00		4,00	6260	73	62
TCMP-1435-4T-7.5 IE3	1465		10,30	5,97	5,50	7210	75	72
TCMP-1435-4T-10 IE3	1465		13,90	8,06	7,50	9380	74	80
TCMP-1435-6T IE3	950	9,08	5,22		2,20	6400	63	57

Características técnicas

Modelo	Velocidad (r/min)	Intensidad máxima admisible (A)			Potencia instalada (kW)	Caudal máximo (m³/h)	Nivel presión sonora dB (A)	Peso aprox. (Kg)
		230V	400V	690V				
TCMP-1640-4T-5.5 IE3	1450	13,90	8,00		4,00	7000	72	81
TCMP-1640-4T-7.5 IE3	1465		10,30	5,97	5,50	8040	75	91
TCMP-1640-4T-10 IE3	1465		13,90	8,06	7,50	9710	74	99
TCMP-1640-6T IE3	950	9,08	5,22		2,20	8100	66	76
TCMP-1845-4T-7.5 IE3	1465		10,30	5,97	5,50	8000	79	100
TCMP-1845-4T-10 IE3	1465		13,90	8,06	7,50	10000	79	108
TCMP-1845-6T IE3	950	9,08	5,22		2,20	7500	74	85
TCMP-2050-4T-10 IE3	1465		13,90	8,06	7,50	9000	77	130
TCMP-2050-4T-15 IE3	1470		20,90	12,10	11,00	12520	81	154
TCMP-2050-4T-20 IE3	1465		27,90	16,20	15,00	16500	83	166
TCMP-2050-6T IE3	960	15,60	8,99		4,00	11000	76	125



Erp. (Energy Related Products)

Información de la Directiva 2009/125/EC descargable desde la web de SODECA o programa de selección QuickFan

Características acústicas

Los valores indicados, se determinan mediante medidas de nivel de presión y potencia sonora en dB(A) obtenidas en campo libre a una distancia equivalente a dos veces la envergadura del ventilador más el diámetro de la turbina, con un mínimo de 1,5 m.

Espectro de potencia sonora Lw(A) en dB(A) por banda de frecuencia en Hz

	63	125	250	500	1000	2000	4000	8000		63	125	250	500	1000	2000	4000	8000
TCMP-820-4T	40	50	61	68	72	69	67	60	TCMP-1435-4T-10	57	66	77	84	88	86	84	77
TCMP-922-4T	41	51	62	69	73	70	68	61	TCMP-1435-6T	46	55	66	73	77	75	73	66
TCMP-1025-4T-1.5	45	55	66	73	77	74	72	65	TCMP-1640-4T-5.5	55	64	75	82	86	84	82	75
TCMP-1025-4T-2	47	57	68	75	79	76	74	67	TCMP-1640-4T-7.5	58	67	78	85	89	87	85	78
TCMP-1128-4T-3	49	59	70	77	81	78	76	69	TCMP-1640-4T-10	57	66	77	84	88	86	84	77
TCMP-1128-4T-4	50	60	71	78	82	79	77	70	TCMP-1640-6T	49	58	69	76	80	78	76	69
TCMP-1128-6T	35	45	56	63	67	64	62	55	TCMP-1845-4T-7.5	61	71	82	89	93	91	89	81
TCMP-1231-4T-3	51	60	71	78	82	80	78	71	TCMP-1845-4T-10	61	71	82	89	93	91	89	81
TCMP-1231-4T-4	53	62	73	80	84	82	80	73	TCMP-1845-6T	56	66	77	84	88	86	84	76
TCMP-1231-4T-5.5	55	64	75	82	86	84	82	75	TCMP-2050-4T-10	59	69	80	87	91	89	87	79
TCMP-1231-6T	42	51	62	69	73	71	69	62	TCMP-2050-4T-15	63	73	84	91	95	93	91	83
TCMP-1435-4T-4	54	63	74	81	85	83	81	74	TCMP-2050-4T-20	65	75	86	93	97	95	93	85
TCMP-1435-4T-5.5	56	65	76	83	87	85	83	76	TCMP-2050-6T	58	68	79	86	90	88	86	78
TCMP-1435-4T-7.5	58	67	78	85	89	87	85	78									

Orientaciones

Suministro standard LG 270

Posiciones LG 180 y RD 180 bajo demanda y con medidas de anclaje especiales.

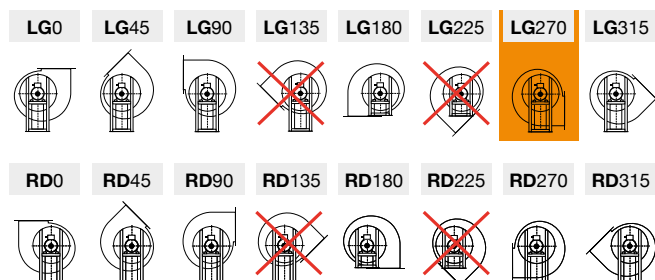

Dimensiones mm

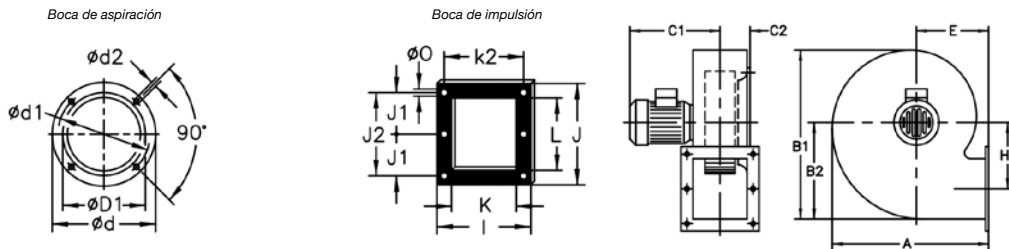

	A	B1	B2	C1	C2	ØD1*	Ød	Ød1	Ød2	E	H1	I	J	J1	J2	K	k2	L	Ø0
TCMP- 820-4T	322	377	223	300	68	203	245	230	M6	137	137	184	213	95	189	134	160	158	9

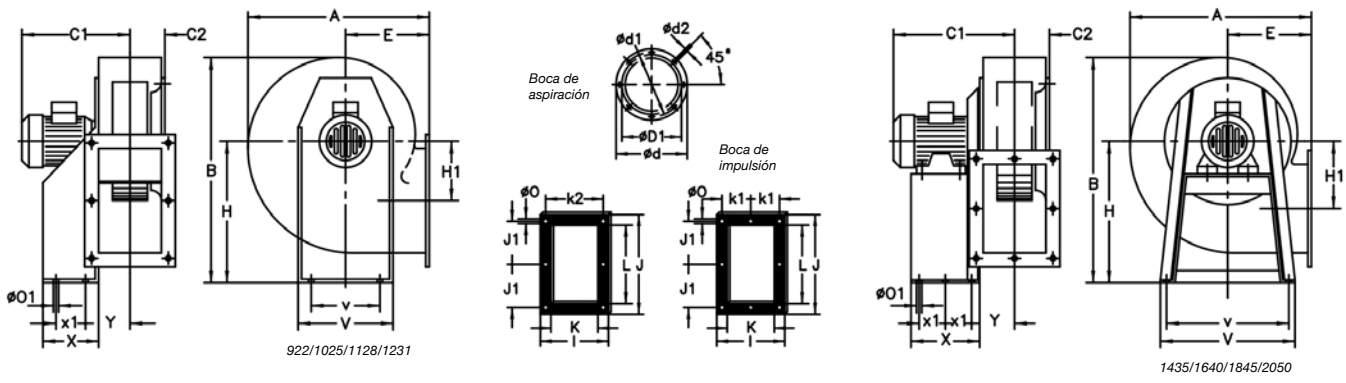

	A	B	C1	C2	ØD1*	Ød	Ød1	Ød2	E	H	H1	I	J	J1	K	k1	k2	L	Ø0	Ø01	V	v	X	x1	Y
TCMP-922	388	455	346	73	230	284	256	M8	180	280	134	204	282	128	140	-	180	217	9,5	10,5	290	220	114	50	104
TCMP-1025	427	503	384	86	261	308	282	M8	197	310	144	229	312	145	165	-	205	252	9,5	12,5	315	228	134	74	115
TCMP-1128-4T	472	553	444	94	287	348	320	M8	216	340	152	244	364	170	180	-	220	299	10	12,5	348	245	144	95	122
TCMP-1128-6T	472	553	359	93	287	348	320	M8	216	340	152	244	364	170	180	-	220	299	10	12,5	348	245	144	95	122
TCMP-1231-3	526	631	432	103	315	382	354	M8	238	390	179	264	382	180	200	-	240	322	12	13	382	322	183	140	125
TCMP-1231-4	526	631	432	103	315	382	354	M8	238	390	179	264	382	180	200	-	240	322	12	13	382	322	183	140	125
TCMP-1231-5.5	526	631	455	103	315	382	354	M8	238	390	179	264	382	180	200	-	240	322	12	13	382	322	183	140	125
TCMP-1231-6T	526	631	432	103	315	382	354	M8	238	390	179	264	382	180	200	-	240	322	12	13	382	322	183	140	125
TCMP-1435-4	573	715	453	118	355	422	394	M8	250	445	242	292	342	159	228	133	-	282	11,5	12	456	420	333	136,5	149,5
TCMP-1435-5.5	573	715	469	118	355	422	394	M8	250	445	242	292	342	159	228	133	-	282	11,5	12	456	420	333	136,5	149,5
TCMP-1435-7.5	573,5	715	512	118	355	422	394	M8	250	445	242	292	342	159	228	133	-	280	11,5	12	456	420	333	136,5	149,5
TCMP-1435-10	573,5	715	512	118	355	422	394	M8	250	445	242	292	342	159	228	133	-	280	11,5	12	456	420	333	136,5	149,5
TCMP-1435-6T	573	715	469	118	355	422	394	M8	250	445	242	292	342	159	228	133	-	282	11,5	12	456	420	333	136,5	149,5
TCMP-1640-5.5	634	799	480	130	402	464	438	M8	270	495	271	336	404	185	250	150	-	324	11,5	12	500	460	327	134	161
TCMP-1640-7.5	634	799	553	130	402	464	438	M8	270	495	271	336	404	185	250	150	-	324	11,5	12	500	460	327	134	161
TCMP-1640-10	634	799	553	130	402	464	438	M8	270	495	271	336	404	185	250	150	-	324	11,5	12	500	460	327	134	161
TCMP-1640-6T	634	799	480	130	402	464	438	M8	270	495	271	336	404	185	250	150	-	324	11,5	12	500	460	327	134	161
TCMP-1845-4T	710	901	570	147	453	515	485	M8	302	560	305	370	444	202	284	164	-	364	11,5	12	538	502	340	140	178
TCMP-1845-6T	710	901	497	147	453	515	485	M8	302	560	305	370	444	202	284	164	-	364	11,5	12	538	502	340	140	178
TCMP-2050-10	797	987	600	162	500	565	535	M8	345	610	313	411	544	250	315	182,5	-	454	11,5	12	653	615	435	187,5	194,5
TCMP-2050-15	797	987	694	162	500	565	535	M8	345	610	313	411	544	250	315	182,5	-	454	11,5	12	653	615	435	187,5	194,5
TCMP-2050-20	797	987	694	162	500	565	535	M8	345	610	313	411	544	250	315	182,5	-	454	11,5	12	653	615	435	187,5	194,5
TCMP-2050-6T	797	987	600	162	500	565	535	M8	345	610	313	411	544	250	315	182,5	-	454	11,5	12	653	615	435	187,5	194,5

* Diámetro nominal tubería recomendada

Curvas características

Q= Caudal en m³/h, m³/s y cfm

Pe= Presión estática en mmH₂O, Pa e inwg

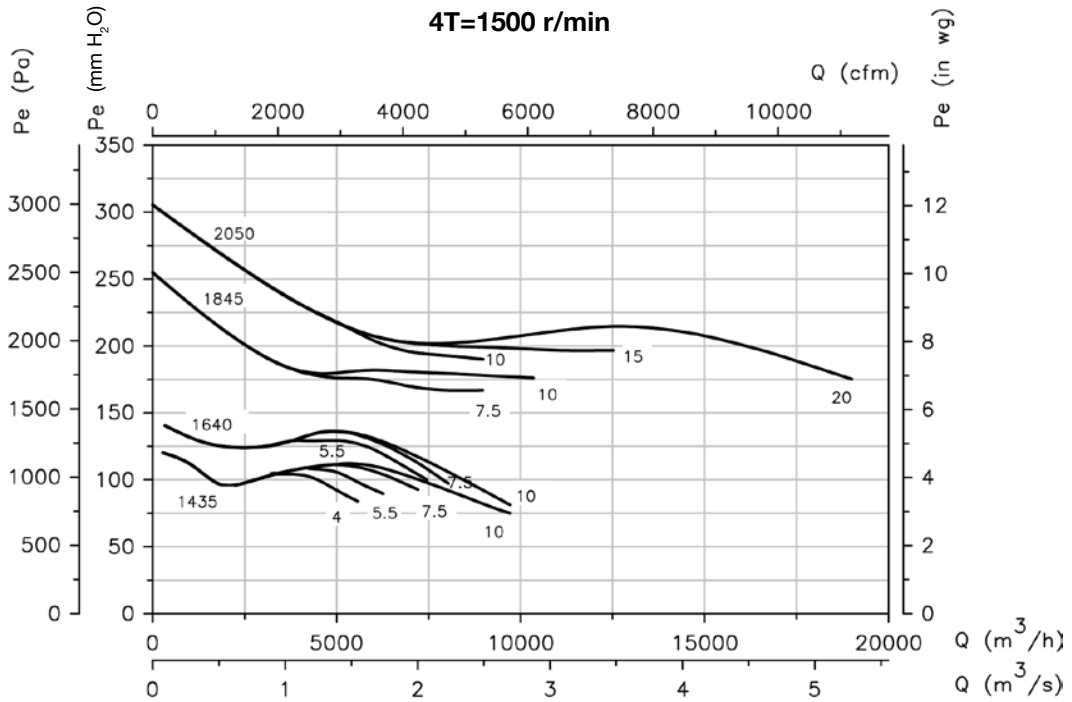
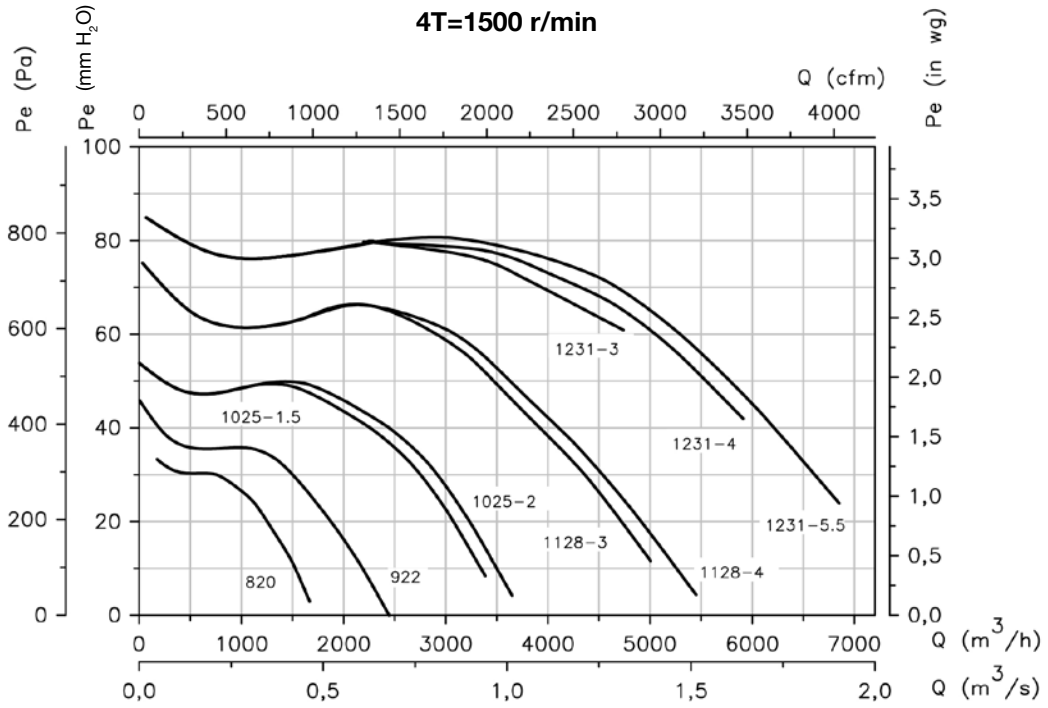

Curvas características

Q= Caudal en m³/h, m³/s y cfm

Pe= Presión estática en mmH₂O, Pa e inwg

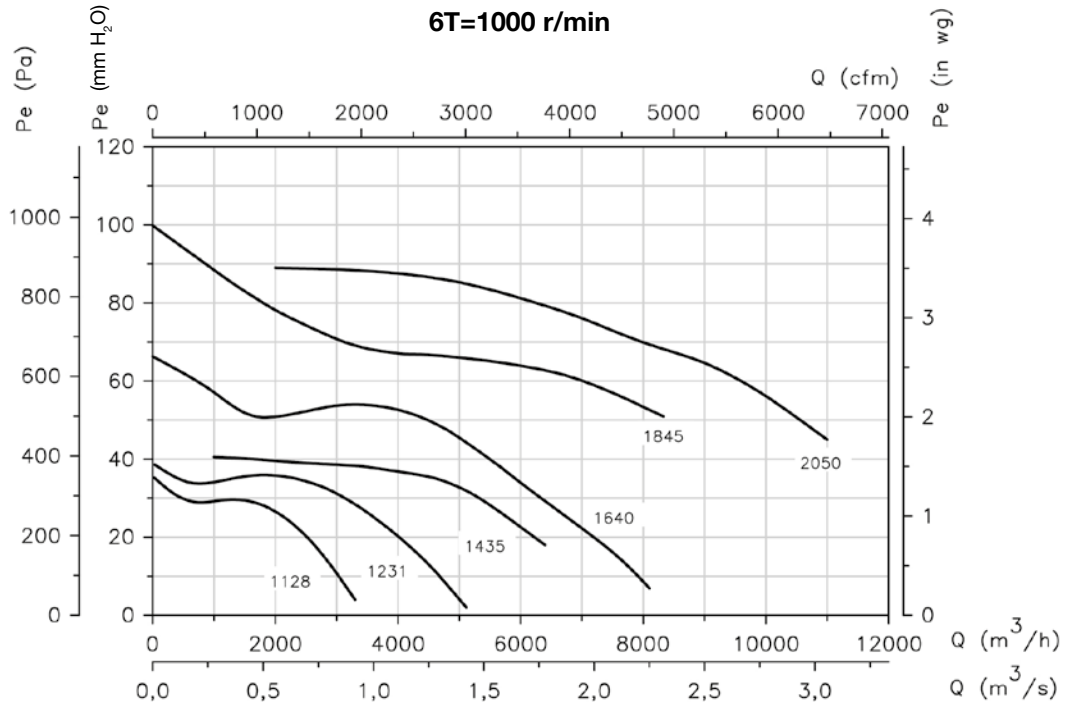

Accesorios



INT



IAT



CABLE BOX



C2V



VSD3/A-RFT
- VSD1/A-RFM



CENTRAL CO



AET



RPA



B



BD



BIC



VIS



ACE ACE/400



TEJ



S

CJMP

Unidades de extracción 400 °C/2h, con turbina a acción



Unidades de extracción 400 °C/2h con caja aislada acústicamente, para trabajar en el exterior de la zona de riesgo de incendios. De simple aspiración.

Ventilador:

- Envoltente en chapa de acero.
- Turbina a acción en chapa de acero galvanizado.
- Homologación según norma EN 12101-3, con certificación n°: 0370-CPR-0402.

Motor:

- Motores clase F con rodamientos a bolas y protección IP55.
- Motores con eficiencia IE3 para potencias iguales o superiores a 0,75 kW, excepto monofásicos, 2 velocidades y 8 polos.

- Trifásico 230/400 V 50 Hz (hasta 4 kW) y 400/690 V 50 Hz (potencias superiores a 4 kW).
- Temperatura máxima del aire a transportar: Servicio S1 -20 °C +250 °C en continuo. Servicio S2 300 °C/2h y 400 °C/2h.

Acabado:

- Anticorrosivo en chapa de acero galvanizado.

Bajo demanda:

- Extractores con motor de 2 velocidades.
- Extractores a transmisión.

Código de pedido

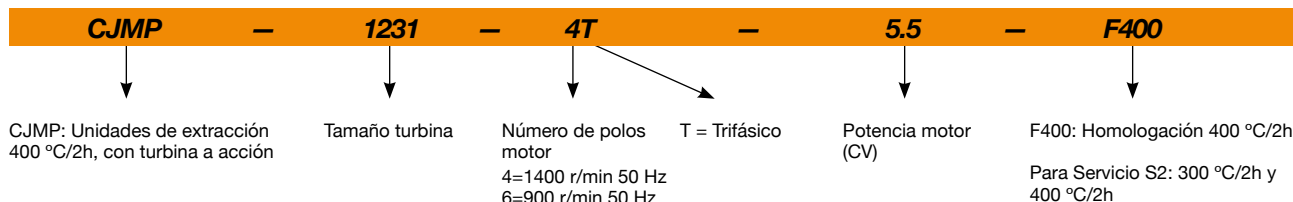

Características técnicas

Modelo	Velocidad (r/min)	Intensidad máxima admisible (A)			Potencia instalada (kW)	Caudal máximo (m³/h)	Nivel presión sonora dB (A)	Peso aprox. (Kg)
		230V	400V	690V				
CJMP-820-4T	1350	1,66	0,96		0,25	1670	52	25
CJMP-922-4T	1380	2,92	1,69		0,55	2450	53	55
CJMP-1025-4T-1.5 IE3	1455	4,07	2,34		1,10	3400	57	69
CJMP-1025-4T-2 IE3	1440	5,41	3,11		1,50	3650	59	72
CJMP-1128-4T-3 IE3	1435	7,93	4,56		2,20	5000	61	87
CJMP-1128-4T-4 IE3	1440	10,70	6,15		3,00	5450	62	90
CJMP-1128-6T IE3	940	3,36	1,93		0,75	3300	48	79
CJMP-1231-4T-3 IE3	1435	7,93	4,56		2,20	4740	62	103
CJMP-1231-4T-4 IE3	1440	10,70	6,15		3,00	5910	64	106
CJMP-1231-4T-5.5 IE3	1450	13,90	8,00		4,00	6850	66	113
CJMP-1231-6T IE3	950	6,43	3,70		1,50	5120	54	103
CJMP-1435-4T-4 IE3	1440	10,70	6,15		3,00	5400	65	126
CJMP-1435-4T-5.5 IE3	1450	13,90	8,00		4,00	6260	67	133
CJMP-1435-4T-7.5 IE3	1465		10,30	5,97	5,50	7210	69	143
CJMP-1435-4T-10 IE3	1465		13,90	8,06	7,50	9380	74	151
CJMP-1435-6T IE3	950	9,08	5,22		2,20	6400	58	128

Características técnicas

Modelo	Velocidad (r/min)	Intensidad máxima admisible (A)			Potencia instalada (kW)	Caudal máximo (m³/h)	Nivel presión sonora dB (A)	Peso aprox. (Kg)
		230V	400V	690V				
CJMP-1640-4T-5.5 IE3	1450	13,90	8,00		4,00	7000	66	151
CJMP-1640-4T-7.5 IE3	1465		10,30	5,97	5,50	8040	69	161
CJMP-1640-4T-10 IE3	1465		13,90	8,06	7,50	9710	74	169
CJMP-1640-6T IE3	950	9,08	5,22		2,20	8100	61	146
CJMP-1845-4T-7.5 IE3	1465		10,30	5,97	5,50	8000	73	181
CJMP-1845-4T-10 IE3	1465		13,90	8,06	7,50	10000	79	189
CJMP-1845-6T IE3	950	9,08	5,22		2,20	7500	69	166
CJMP-2050-4T-10 IE3	1465		13,90	8,06	7,50	9000	77	233
CJMP-2050-4T-15 IE3	1470		20,90	12,10	11,00	12520	81	257
CJMP-2050-4T-20 IE3	1465		27,90	16,20	15,00	16500	83	269
CJMP-2050-6T IE3	960	15,60	8,99		4,00	11000	71	228



Erp. (Energy Related Products)

Información de la Directiva 2009/125/EC descargable desde la web de SODECA o programa de selección QuickFan

Características acústicas

Los valores indicados, se determinan mediante medidas de nivel de presión y potencia sonora en dB(A) obtenidas en campo libre a una distancia equivalente a dos veces la envergadura del ventilador más el diámetro de la turbina, con un mínimo de 1,5 m.

Espectro de potencia sonora Lw(A) en dB(A) por banda de frecuencia en Hz

	63	125	250	500	1000	2000	4000	8000		63	125	250	500	1000	2000	4000	8000
CJMP-820-4T	34	44	55	62	66	63	61	54	CJMP-1435-4T-10	57	66	77	84	88	86	84	77
CJMP-922-4T	35	45	56	63	67	64	62	55	CJMP-1435-6T	41	50	61	68	72	70	68	61
CJMP-1025-4T-1.5	39	49	60	67	71	68	66	59	CJMP-1640-4T-5.5	49	58	69	76	80	78	76	69
CJMP-1025-4T-2	41	51	62	69	73	70	68	61	CJMP-1640-4T-7.5	52	61	72	79	83	81	79	72
CJMP-1128-4T-3	43	53	64	71	75	72	70	63	CJMP-1640-4T-10	57	66	77	84	88	86	84	77
CJMP-1128-4T-4	44	54	65	72	76	73	71	64	CJMP-1640-6T	44	53	64	71	75	73	71	64
CJMP-1128-6T	30	40	51	58	62	59	57	50	CJMP-1845-4T-7.5	55	65	76	83	87	85	83	75
CJMP-1231-4T-3	45	54	65	72	76	74	72	65	CJMP-1845-4T-10	61	71	82	89	93	91	89	81
CJMP-1231-4T-4	47	56	67	74	78	76	74	67	CJMP-1845-6T	51	61	72	79	83	81	79	71
CJMP-1231-4T-5.5	49	58	69	76	80	78	76	69	CJMP-2050-4T-10	59	69	80	87	91	89	87	79
CJMP-1231-6T	37	46	57	64	68	66	64	57	CJMP-2050-4T-15	63	73	84	91	95	93	91	83
CJMP-1435-4T-4	48	57	68	75	79	77	75	68	CJMP-2050-4T-20	65	75	86	93	97	95	93	85
CJMP-1435-4T-5.5	50	59	70	77	81	79	77	70	CJMP-2050-6T	53	63	74	81	85	83	81	73
CJMP-1435-4T-7.5	52	61	72	79	83	81	79	72									

Orientaciones

Suministro standard LG 270

Posiciones LG 180 y RD 180 bajo demanda y con medidas de anclaje especiales.



Dimensiones mm

Suministro standard: LG-270

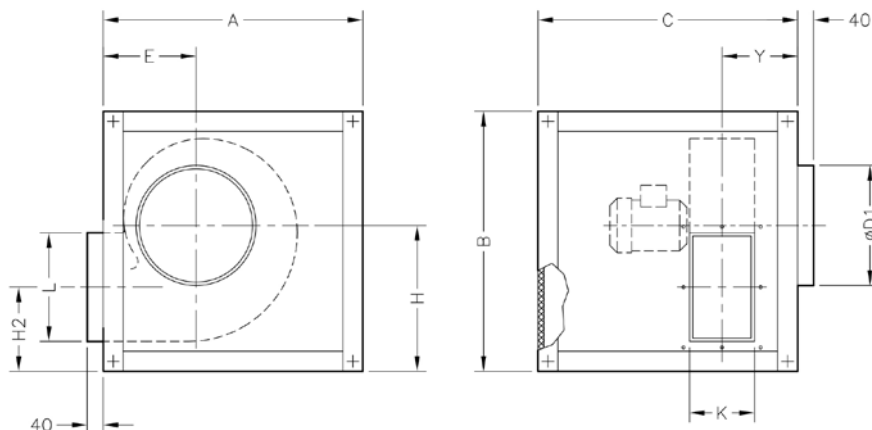

	A	B	C	ØD1	E	H	H2	K	L	Y
CJMP-820	400	450	450	200	142	263	126	130	156	112
CJMP-922	610	610	610	224	187	349	215	140	215	176
CJMP-1025	660	660	660	250	204	379	235	165	250	178,5
CJMP-1128	720	720	720	280	223	409	257	180	295	191
CJMP-1231	800	800	800	315	245	459	279,5	200	320	205
CJMP-1435	880	880	880	355	257	514	271,5	230	280	291
CJMP-1640	970	970	970	400	277	564	293	250	320	324
CJMP-1845	1070	1070	1070	450	309	629	324	284	360	357
CJMP-2050	1160	1160	1160	500	352	679	366	315	450	385,5

Suministro bajo demanda: LG-90

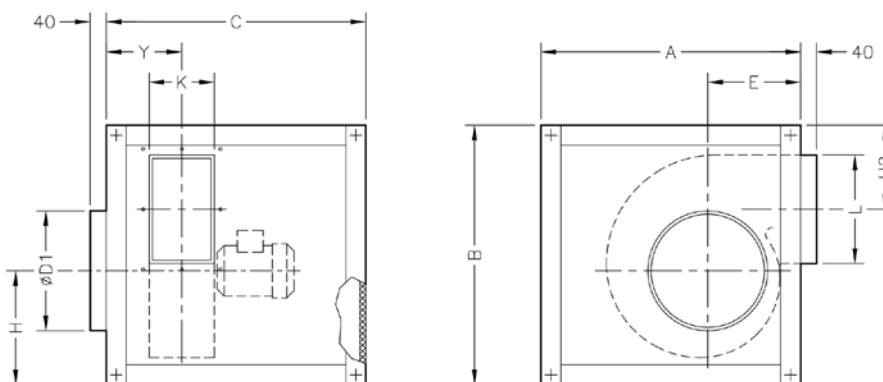

	A	B	C	ØD1	E	H	H2	K	L	Y
CJMP-922	720	720	720	224	187	349	237	140	215	176
CJMP-1025	800	800	800	250	204	379	277	165	250	178
CJMP-1128	880	880	880	280	223	409	319	180	295	191
CJMP-1231	970	970	970	315	245	459	332	200	320	205
CJMP-1435	1070	1070	1070	355	257	514	314	230	280	291
CJMP-1640	1160	1160	1160	400	277	564	325	250	320	325
CJMP-1845	865	1260	1050	450	309	629	326	284	360	357
CJMP-2050	965	1400	1200	500	352	679	408	315	450	383,5

Dimensiones mm

Suministro bajo demanda: LG-0

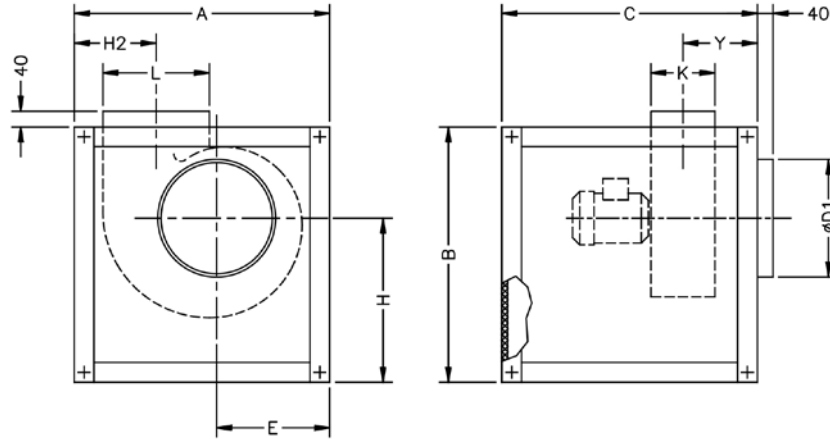

	A	B	C	ØD1	E	H	H2	K	L	Y
CJMP-922	610	610	610	224	279	349	197	140	215	176
CJMP-1025	660	660	660	250	302	379	214	165	250	178,5
CJMP-1128	720	720	720	280	335	409	233	180	295	191
CJMP-1231	800	800	800	315	366	459	255	200	320	205
CJMP-1435	880	880	880	355	385	514	253	230	280	291
CJMP-1640	970	970	970	400	412	564	287	250	320	324
CJMP-1845	1070	1070	1070	450	446	629	319	284	360	357
CJMP-2050	1160	1160	1160	500	485	679	362	315	450	383,5

Boca de impulsión

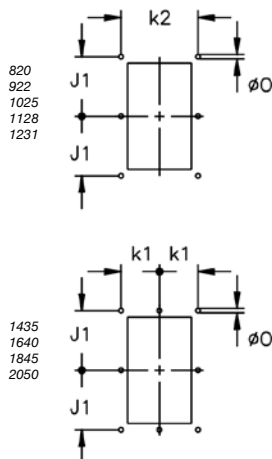

	k1	k2	J1	ØO
CJMP-820	-	160	94,5	9
CJMP-922	-	180	128	9,5
CJMP-1025	-	205	145	9,5
CJMP-1128	-	220	170	9,5
CJMP-1231	-	240	180	11,5
CJMP-1435	133	-	159	11,5
CJMP-1640	150	-	185	11,5
CJMP-1845	164	-	202	11,5
CJMP-2050	182,5	-	250	11,5

Curvas características

Q= Caudal en m³/h, m³/s y cfm

Pe= Presión estática en mmH₂O, Pa e inwg

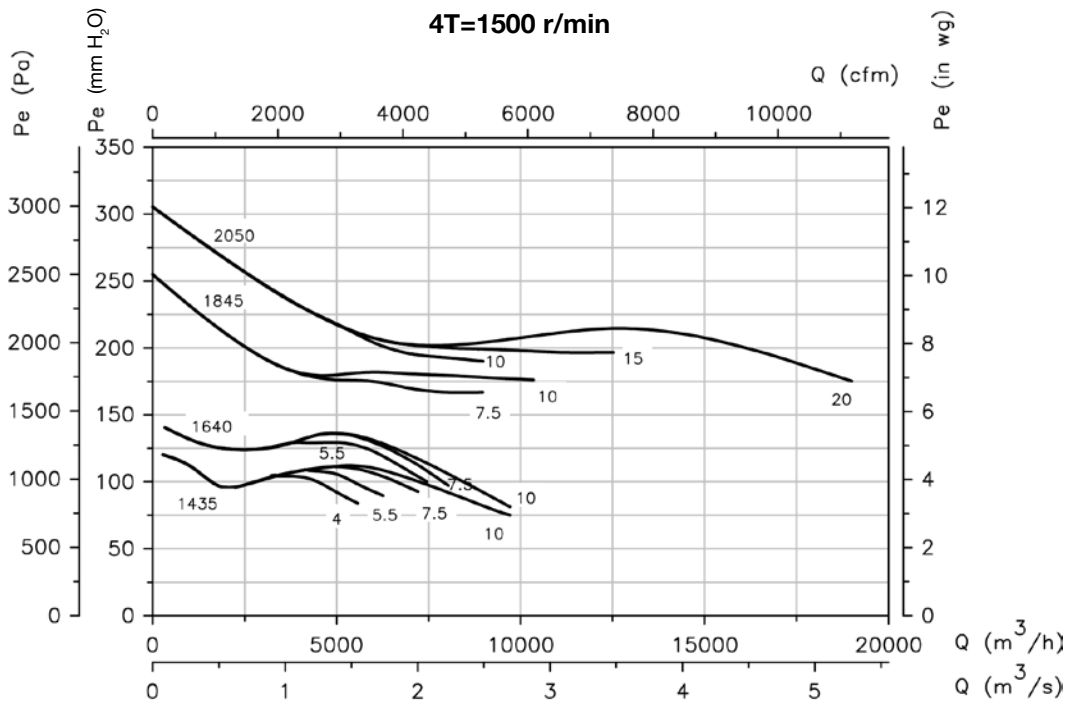
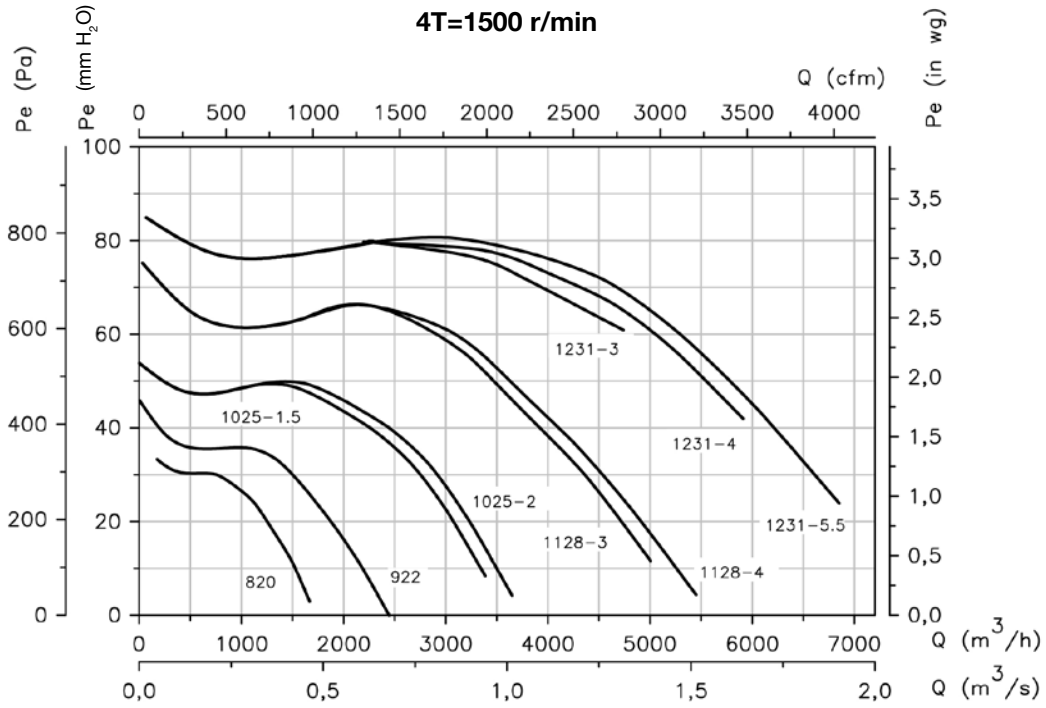

Curvas características

Q= Caudal en m³/h, m³/s y cfm

Pe= Presión estática en mmH₂O, Pa e inwg

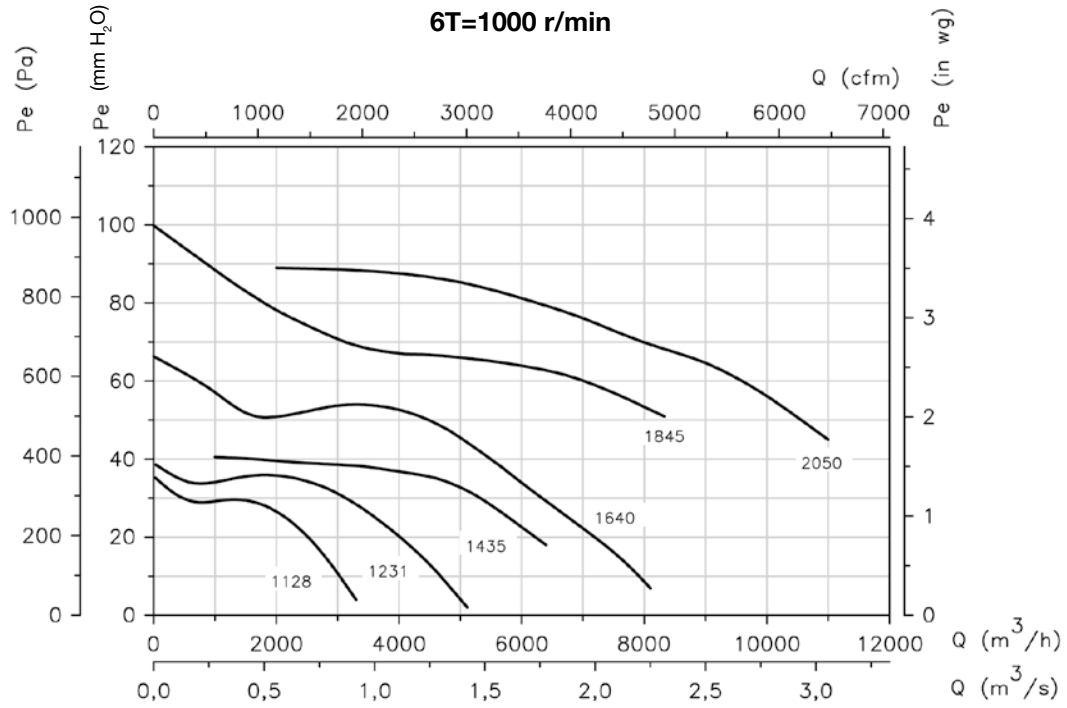

Accesorios



INT



IAT



CABLE BOX



C2V



VSD3/A-RFT
- VSD1/A-RFM



CENTRAL CO



AET



RPA



B



BD



BIC



VIS



ACE ACE/400



TEJ

CJTX-C

Unidades de extracción 400 °C/2h, a transmisión con ventilador de doble aspiración



Unidades de extracción 400 °C/2h, con motor y transmisión en el interior de la caja, para trabajar en el exterior de la zona de riesgo de incendios.

Ventilador:

- Estructura en chapa de acero galvanizado.
- Turbina a acción en chapa de acero galvanizado.
- Homologación según norma EN 12101-3, con certificación n°: 0370-CPR-0468.
- Dirección aire sentido lineal.

Motor:

- Motores clase F con rodamientos a bolas, protección IP55, de 1 o 2 velocidades según modelo.

- Motores con eficiencia IE3 para potencias iguales o superiores a 0,75 kW, excepto monofásicos, 2 velocidades y 8 polos.
- Trifásico 230/400 V 50 Hz (hasta 4 kW) y 400/690 V 50 Hz (potencias superiores a 4 kW).
- Temperatura máxima del aire a transportar: Servicio S1 -25 °C +120 °C en continuo. Servicio S2 300 °C/2h y 400 °C/2h.

Acabado:

- Anticorrosivo en chapa de acero galvanizado.

Bajo demanda:

- Extractores con salida vertical.

Código de pedido

CJTX-C	—	15/15	—	10	—	2V	—	F400
↓		↓		↓		↓		↓
CJTX-C: Unidades de extracción 400 °C/2h, a transmisión con ventilador de doble aspiración		Tamaño turbina		Potencia motor (CV)		Referencia con 2V: Ventilador con 2 velocidades		F400: Homologación 400 °C/2h Para Servicio S2: 300 °C/2h y 400 °C/2h

Características técnicas

Modelo	Velocidad (r/min)	Intensidad máxima admisible (A)			Potencia instalada (kW)	Caudal máximo (m³/h)	Nivel presión sonora dB (A)	Peso aprox. (Kg)
		230V	400V	690V				
CJTX-C-7/7-0.75	1400	2,92	1,69		0,55	2450	57	58
CJTX-C-7/7-0.75-2V	1400 / 695		1,70 / 0,80		0,55 / 0,19	2450 / 1220	57 / 41	58
CJTX-C-7/7-1 IE3	1600	2,82	1,62		0,75	2800	61	63
CJTX-C-7/7-1-2V	1600 / 795		2,00 / 0,90		0,75 / 0,20	2800 / 1390	61 / 46	61
CJTX-C-9/9-0.33-2V	850 / 425		0,70 / 0,30		0,25 / 0,10	2900 / 1450	48 / 32	65
CJTX-C-9/9-0.5	960	2,02	1,17		0,37	3300	51	66
CJTX-C-9/9-0.5-2V	960 / 470		1,05 / 0,50		0,37 / 0,11	3300 / 1600	51 / 36	67
CJTX-C-9/9-0.75	1060	2,92	1,69		0,55	3800	55	69
CJTX-C-9/9-1 IE3	1200	2,82	1,62		0,75	4250	58	74
CJTX-C-9/9-1.5 IE3	1340	4,07	2,34		1,10	4800	61	84
CJTX-C-9/9-2 IE3	1500	5,41	3,11		1,50	5350	65	92
CJTX-C-10/10-0.33	660	1,66	0,96		0,25	3000	44	77
CJTX-C-10/10-0.33-2V	660 / 330		0,70 / 0,30		0,25 / 0,10	3000 / 1500	44 / 29	77
CJTX-C-10/10-0.5	800	2,02	1,17		0,37	3400	49	77
CJTX-C-10/10-0.5-2V	800 / 390		1,05 / 0,50		0,37 / 0,11	3400 / 1650	49 / 34	79
CJTX-C-10/10-0.75	880	2,92	1,69		0,55	4000	54	81

Características técnicas

Modelo	Velocidad (r/min)	Intensidad máxima admisible (A)			Potencia instalada (kW)	Caudal máximo (m³/h)	Nivel presión sonora dB (A)	Peso aprox. (Kg)
		230V	400V	690V				
CJTX-C-10/10-0.75-2V	880 / 440		1,70 / 0,80		0,55 / 0,19	4000 / 1990	54 / 38	81
CJTX-C-10/10-1 IE3	1000	2,82	1,62		0,75	4350	58	86
CJTX-C-10/10-1-2V	1000 / 500		2 / 0,9		0,75 / 0,20	4350 / 2160	58 / 43	84
CJTX-C-10/10-1.5 IE3	1130	4,07	2,34		1,10	5000	61	96
CJTX-C-10/10-2 IE3	1270	5,41	3,11		1,50	5450	63	102
CJTX-C-10/10-3 IE3	1450	7,93	4,56		2,20	6200	67	90
CJTX-C-12/12-0.5	600	2,02	1,17		0,37	4300	54	96
CJTX-C-12/12-0.5-2V	600 / 295		1,05 / 0,50		0,37 / 0,11	4300 / 2090	54 / 38	98
CJTX-C-12/12-0.75	700	2,92	1,69		0,55	4850	57	99
CJTX-C-12/12-0.75-2V	700 / 350		1,70 / 0,80		0,55 / 0,19	4850 / 2410	57 / 42	100
CJTX-C-12/12-1 IE3	800	2,82	1,62		0,75	5250	60	105
CJTX-C-12/12-1-2V	800 / 400		2,00 / 0,90		0,75 / 0,20	5250 / 2610	60 / 45	103
CJTX-C-12/12-1.5 IE3	880	4,07	2,34		1,10	6150	63	115
CJTX-C-12/12-1.5-2V	880 / 435		2,90 / 1,30		1,10 / 0,25	6150 / 3030	63 / 48	104
CJTX-C-12/12-2 IE3	1020	5,41	3,11		1,50	6600	67	121
CJTX-C-12/12-3 IE3	1140	7,93	4,56		2,20	7600	69	108
CJTX-C-12/12-4 IE3	1250	10,70	6,15		3,00	8550	71	120
CJTX-C-15/15-0.75	530	2,92	1,69		0,55	6000	47	126
CJTX-C-15/15-0.75-2V	530 / 260		1,60 / 0,65		0,55 / 0,09	6000 / 2900	47 / 31	126
CJTX-C-15/15-1 IE3	560	2,82	1,62		0,75	7000	50	131
CJTX-C-15/15-1.5 IE3	630	4,07	2,34		1,10	8050	54	142
CJTX-C-15/15-2 IE3	700	5,41	3,11		1,50	8900	58	149
CJTX-C-15/15-3 IE3	800	7,93	4,56		2,20	10100	64	136
CJTX-C-15/15-4 IE3	880	10,70	6,15		3,00	11350	65	149
CJTX-C-15/15-5.5 IE3	970	13,90	8,00		4,00	12600	68	147
CJTX-C-18/18-1 IE3	460	2,82	1,62		0,75	10100	48	164
CJTX-C-18/18-1-2V	460 / 215		2,20 / 0,87		0,75 / 0,15	10100 / 4700	48 / 31	163
CJTX-C-18/18-1.5 IE3	510	4,07	2,34		1,10	11800	52	175
CJTX-C-18/18-1.5-2V	510 / 255		3,00 / 1,15		1,10 / 0,18	11800 / 5840	52 / 36	165
CJTX-C-18/18-2 IE3	540	5,41	3,11		1,50	13800	55	183
CJTX-C-18/18-2-2V	540 / 265		4,60 / 1,90		1,50 / 0,25	13800 / 6690	55 / 39	167
CJTX-C-18/18-3 IE3	610	7,93	4,56		2,20	15850	60	171
CJTX-C-18/18-3-2V	610 / 305		5,60 / 2,20		2,20 / 0,37	15850 / 7920	60 / 45	173
CJTX-C-18/18-4 IE3	680	10,70	6,15		3,00	17600	64	182
CJTX-C-18/18-4-2V	680 / 340		9,00 / 3,50		3,00 / 0,55	17600 / 8800	64 / 49	180
CJTX-C-18/18-5.5 IE3	750	13,90	8,00		4,00	19450	68	180
CJTX-C-18/18-5.5-2V	750 / 375		11,00 / 4,00		4,00 / 0,65	19450 / 9620	68 / 52	184
CJTX-C-18/18-7.5 IE3	850		10,30	5,97	5,50	21350	72	211
CJTX-C-18/18-7.5-2V	850 / 425		13,20 / 5,30		5,50 / 1,00	21350 / 10560	72 / 57	204
CJTX-C-18/18-10 IE3	930		13,90	8,06	7,50	24000	75	218
CJTX-C-20/20-2 IE3	450	5,41	3,11		1,50	14000	53	284
CJTX-C-20/20-3 IE3	530	7,93	4,56		2,20	15800	59	271
CJTX-C-20/20-4 IE3	580	10,70	6,15		3,00	17950	63	282
CJTX-C-20/20-5.5 IE3	660	13,90	8,00		4,00	19050	67	281
CJTX-C-20/20-7.5 IE3	740		10,30	5,97	5,50	21150	68	312
CJTX-C-20/20-10 IE3	815		13,90	8,06	7,50	23650	70	320
CJTX-C-22/22-2 IE3	380	5,41	3,11		1,50	16000	52	326
CJTX-C-22/22-2-2V	380 / 185		4,60 / 1,90		1,50 / 0,25	16000 / 7750	52 / 37	310
CJTX-C-22/22-3 IE3	430	7,93	4,56		2,20	18400	56	313
CJTX-C-22/22-3-2V	430 / 215		5,60 / 2,20		2,20 / 0,37	18400 / 9200	56 / 41	316
CJTX-C-22/22-4 IE3	480	10,70	6,15		3,00	20350	60	325
CJTX-C-22/22-5.5 IE3	520	13,90	8,00		4,00	23250	64	325
CJTX-C-22/22-7.5 IE3	580		10,30	5,97	5,50	25950	68	356
CJTX-C-22/22-10 IE3	650		13,90	8,06	7,50	28250	71	362

Características técnicas

Modelo	Velocidad (r/min)	Intensidad máxima admisible (A)			Potencia instalada (kW)	Caudal máximo (m³/h)	Nivel presión sonora dB (A)	Peso aprox. (Kg)
		230V	400V	690V				
CJTX-C-22/22-15 IE3	740		20,90	12,10	11,00	31950	73	383
CJTX-C-22/22-20 IE3	780		27,90	16,20	15,00	34000	75	441
CJTX-C-25/25-3 IE3	340	7,93	4,56		2,20	21550	60	370
CJTX-C-25/25-3-2V	340 / 170		5,60 / 2,20		2,20 / 0,37	21550 / 10780	60 / 45	372
CJTX-C-25/25-4 IE3	380	10,70	6,15		3,00	23850	64	381
CJTX-C-25/25-4-2V	380 / 190		9,00 / 3,50		3,00 / 0,55	23850 / 11920	64 / 49	379
CJTX-C-25/25-5.5 IE3	420	13,90	8,00		4,00	26300	69	379
CJTX-C-25/25-5.5-2V	420 / 210		11,00 / 4,00		4,00 / 0,65	26300 / 13010	69 / 53	383
CJTX-C-25/25-7.5 IE3	470		10,30	5,97	5,50	29250	69	416
CJTX-C-25/25-7.5-2V	470 / 235		13,20 / 5,30		5,50 / 1,00	29250 / 14470	69 / 53	409
CJTX-C-25/25-10 IE3	510		13,90	8,06	7,50	33150	71	417
CJTX-C-25/25-10-2V	510 / 255		16,90 / 5,50		7,50 / 1,30	33150 / 16490	71 / 56	412
CJTX-C-25/25-15 IE3	570		20,90	12,10	11,00	38300	74	444
CJTX-C-25/25-15-2V	570 / 285		23,20 / 8,70		11,00 / 2,80	38300 / 19050	74 / 59	450
CJTX-C-25/25-20 IE3	630		27,90	16,20	15,00	38750	77	499
CJTX-C-30/28-3 IE3	250	7,93	4,56		2,20	25550	55	503
CJTX-C-30/28-3-2V	250 / 125		5,60 / 2,20		2,20 / 0,37	25550 / 12780	55 / 40	507
CJTX-C-30/28-4 IE3	280	10,70	6,15		3,00	28250	60	521
CJTX-C-30/28-4-2V	280 / 140		9,00 / 3,50		3,00 / 0,55	28250 / 14120	60 / 45	519
CJTX-C-30/28-5.5 IE3	340	13,90	8,00		4,00	28750	64	519
CJTX-C-30/28-5.5-2V	340 / 170		11,00 / 4,00		4,00 / 0,65	28750 / 14230	64 / 49	523
CJTX-C-30/28-7.5 IE3	360		10,30	5,97	5,50	33600	69	553
CJTX-C-30/28-7.5-2V	360 / 180		13,20 / 5,30		5,50 / 1,00	33600 / 16630	69 / 54	546
CJTX-C-30/28-10 IE3	410		13,90	8,06	7,50	36400	74	561
CJTX-C-30/28-10-2V	410 / 205		16,90 / 5,50		7,50 / 1,30	36400 / 18110	74 / 59	556
CJTX-C-30/28-15 IE3	480		20,90	12,10	11,00	40250	74	582
CJTX-C-30/28-15-2V	480 / 240		23,20 / 8,70		11,00 / 2,80	40250 / 20020	74 / 59	588
CJTX-C-30/28-20 IE3	520		27,90	16,20	15,00	45600	77	644
CJTX-C-30/28-20-2V	520 / 260		31,72 / 11,75		15,00 / 3,80	45600 / 22680	77 / 62	616
CJTX-C-30/28-25 IE3	550		35,10	20,30	18,50	49500	79	641
CJTX-C-30/28-25-2V	550 / 275		33,00 / 11,00		17,00 / 3,40	49500 / 24620	79 / 64	643



Erp. (Energy Related Products)

Información de la Directiva 2009/125/EC descargable desde la web de SODECA o programa de selección QuickFan

Accesorios



INT



IAT



C2V



RPA



B



BD



BIC



ACE ACE/400



CABLE BOX



AET



CENTRAL CO



VSD3/A-RFT
- VSD1/A-RFM



TEJ



VIS

Dimensiones mm

Suministro standard impulsión horizontal (H) LG 90

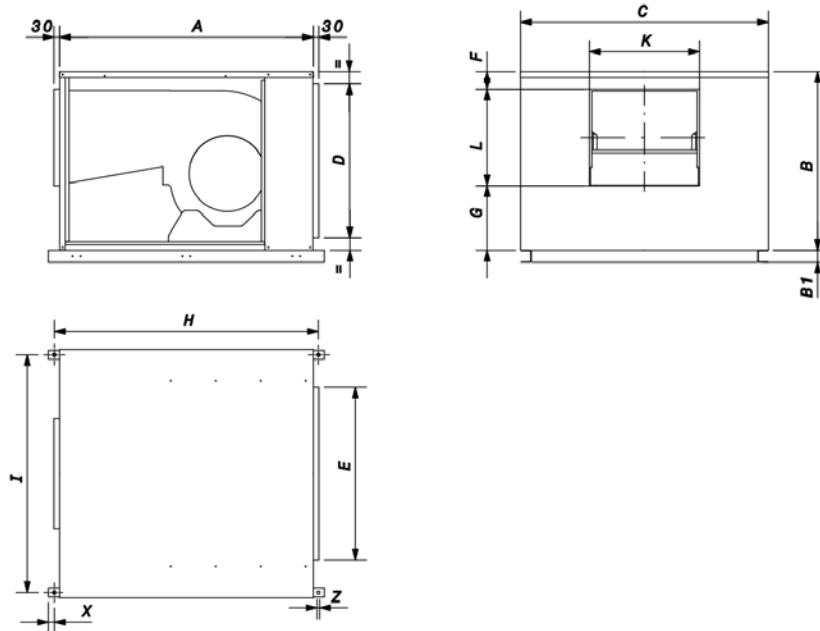

	A	B	B1	C	D	E	F	G	H	I	K	L	X	Z
CJTX-C-7/7	700	480	-	730	354	470	62	202	724	690	239	216	12	9
CJTX-C-9/9	785	592	-	759	466	490	92	226	812	721	310	270	12	9
CJTX-C-10/10	860	618	-	825	492	520	87	235	884	787	334	296	12	9
CJTX-C-12/12	970	680	-	945	554	620	80	250	995	896	395	350	12	9
CJTX-C-15/15	1100	776	-	1100	650	720	80	285	1124	1062	483	411	12	9
CJTX-C-18/18	1278	900	60	1250	774	870	90	325	1328	1197	552	486	30,3	13
CJTX-C-20/20	1495	1050	60	1474	954	1100	100	336	1555	1419	618	615	32,5	13
CJTX-C-22/22	1640	1180	60	1625	954	1100	125	350	1711	1570	665	705	22	13
CJTX-C-25/25	1800	1300	60	1825	1174	1450	125	369	1871	1770	780	806	22	13
CJTX-C-30/28	2000	1525	60	2134	1399	1760	118	465	2060	2085	900	942	20	13

Dimensiones mm

Bajo demanda impulsión vertical
(V) LG 0

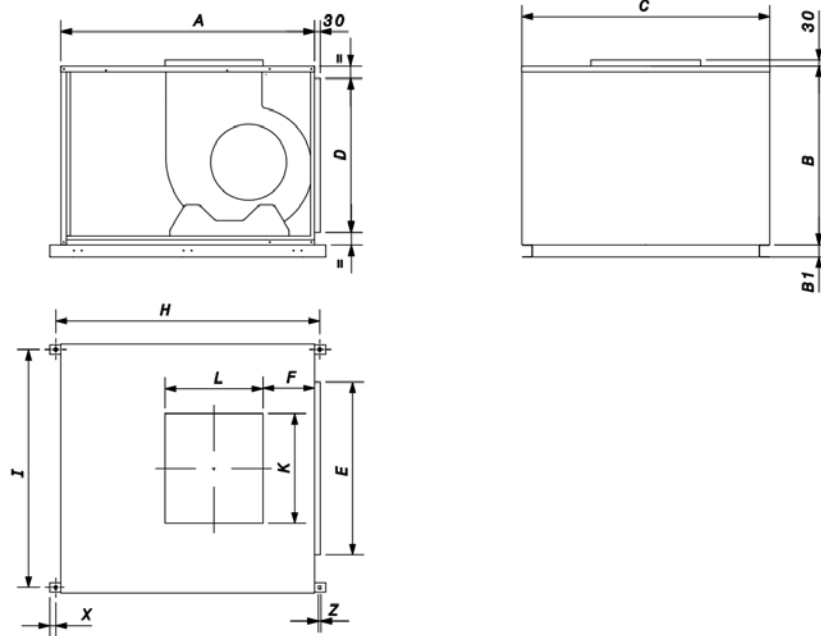

	A	B	B1	C	D	E	F	H	I	K	L	X	Z
CJTX-C-7/7	700	480	-	730	354	470	186	724	690	239	219	12	9
CJTX-C-9/9	785	592	-	759	466	490	170	812	721	305	272	12	9
CJTX-C-10/10	860	618	-	825	492	520	161	884	787	333	300	12	9
CJTX-C-12/12	970	680	-	945	554	620	202	995	896	397	355	12	9
CJTX-C-15/15	1100	776	-	1100	650	720	220	1124	1062	485	415	12	9
CJTX-C-18/18	1278	900	60	1250	774	870	259	1328	1197	550	495	30,3	13
CJTX-C-20/20	1495	1050	60	1474	954	1100	312	1555	1419	617	611	32,5	13
CJTX-C-22/22	1640	1180	60	1625	954	1100	307	1711	1570	666	705	22	13
CJTX-C-25/25	1800	1300	60	1825	1174	1450	334	1871	1770	775	808	22	13
CJTX-C-30/28	2000	1525	60	2134	1399	1760	417	2060	2085	900	947	20	13

Curvas características

Q= Caudal en m³/h, m³/s y cfm

Pe= Presión estática en mmH₂O, Pa e inwg

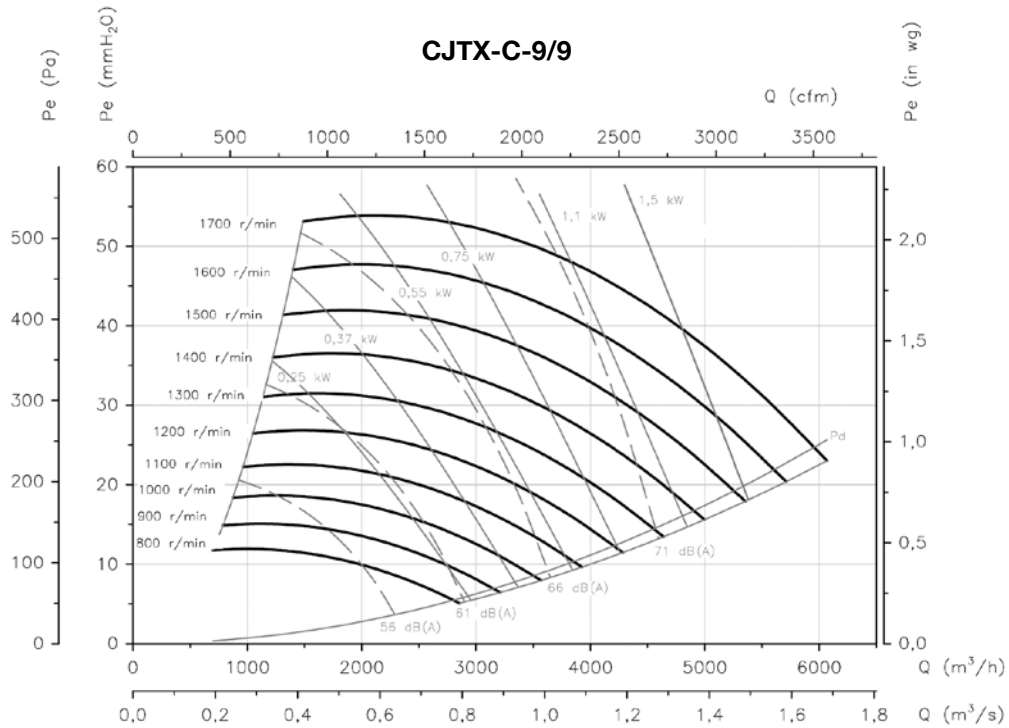
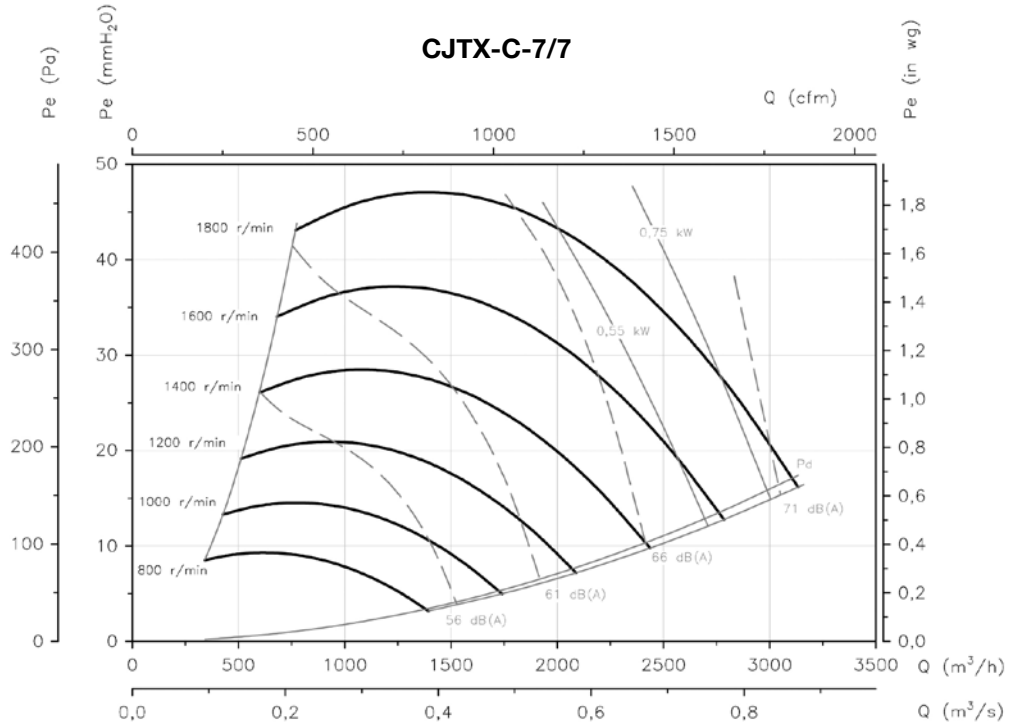

Curvas características

Q= Caudal en m³/h, m³/s y cfm

Pe= Presión estática en mmH₂O, Pa e inwg

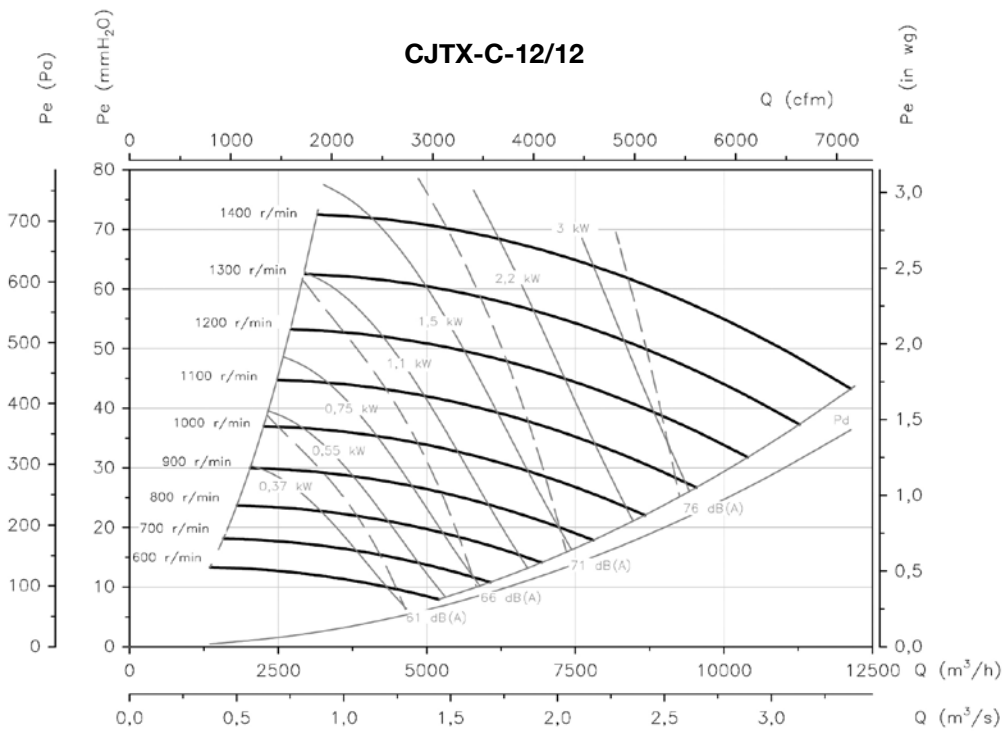
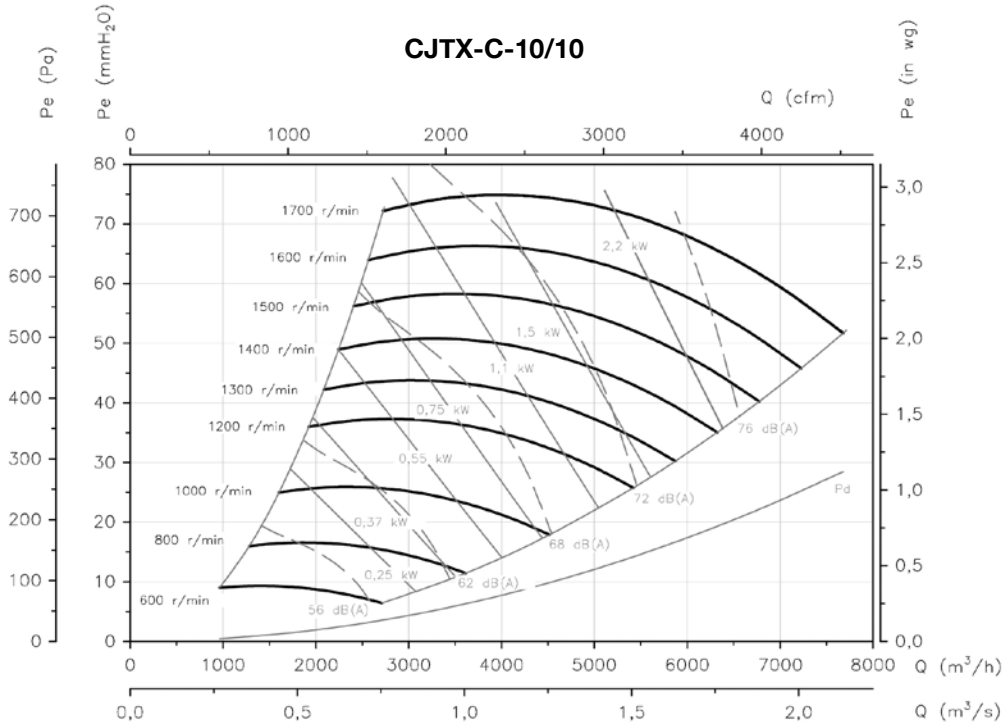

Curvas características

Q= Caudal en m³/h, m³/s y cfm

Pe= Presión estática en mmH₂O, Pa e inwg

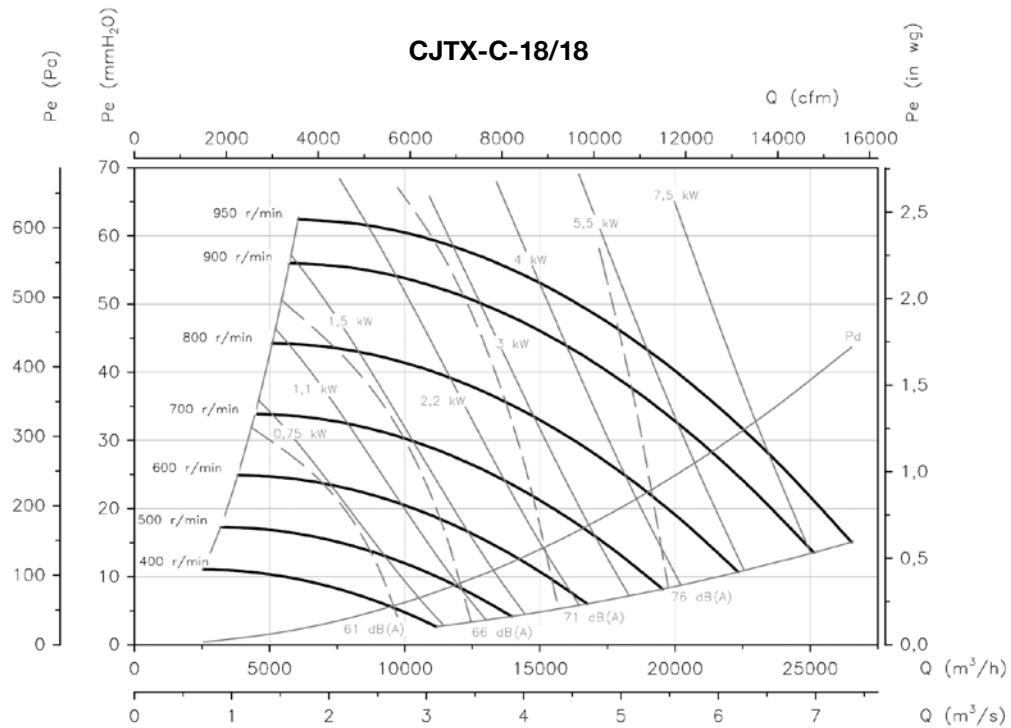
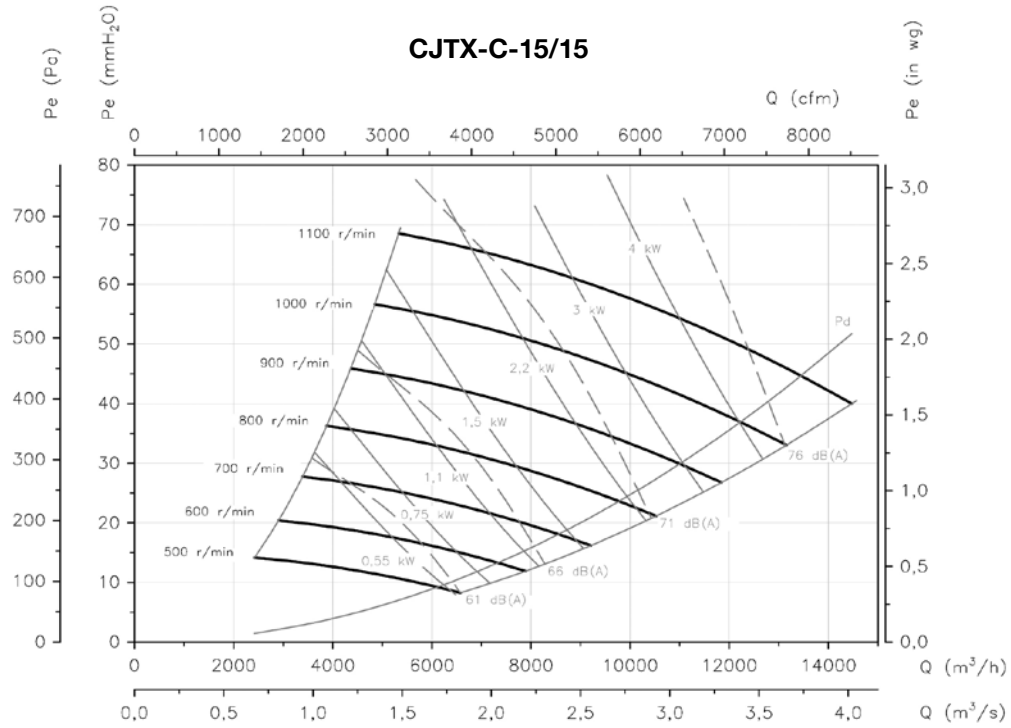

Curvas características

Q= Caudal en m³/h, m³/s y cfm

Pe= Presión estática en mmH₂O, Pa e inwg

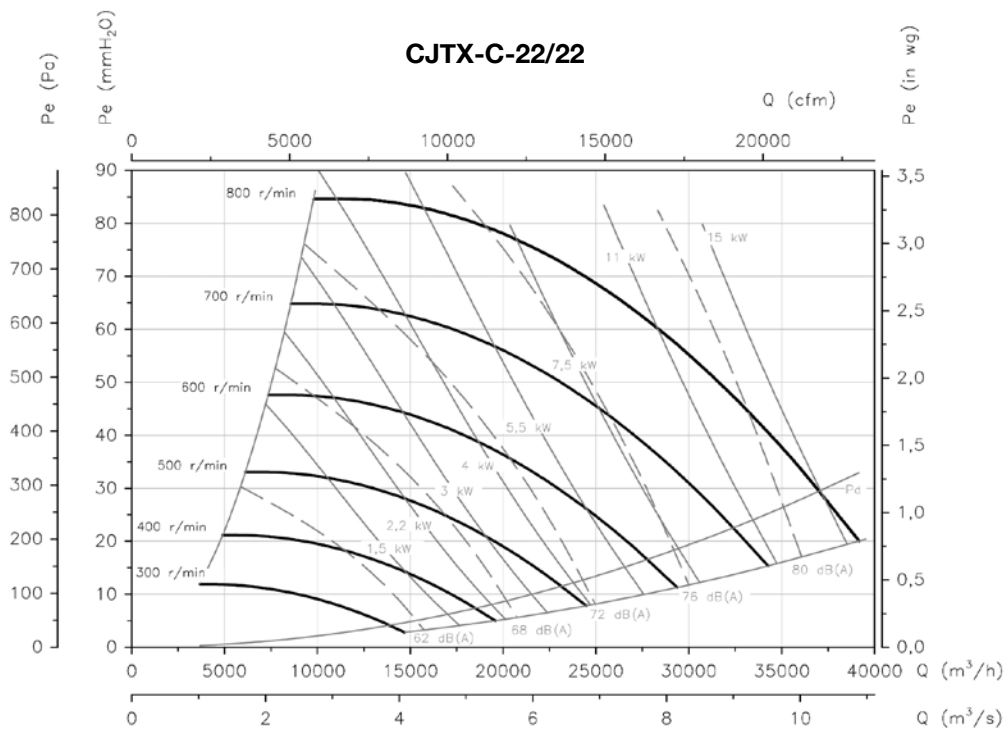
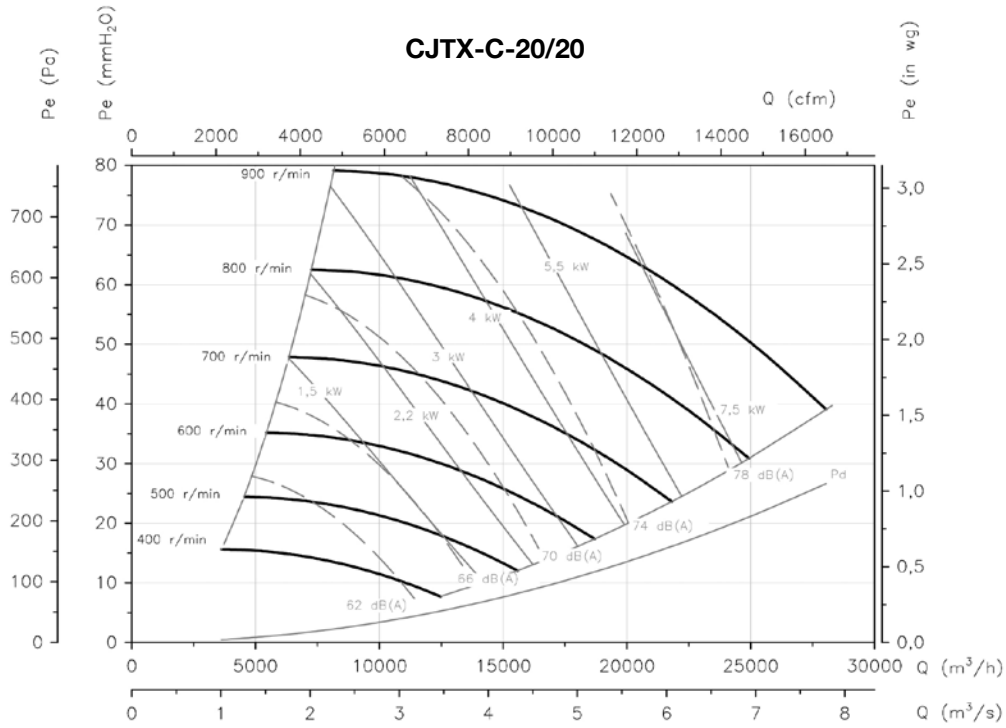

Curvas características

Q= Caudal en m³/h, m³/s y cfm

Pe= Presión estática en mmH₂O, Pa e inwg

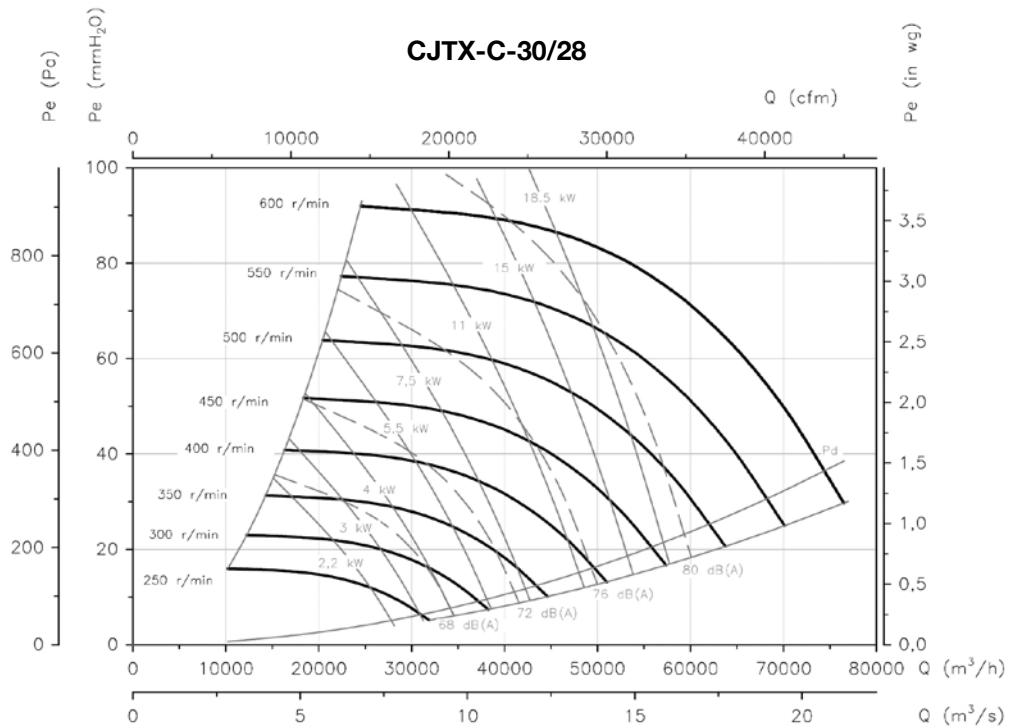
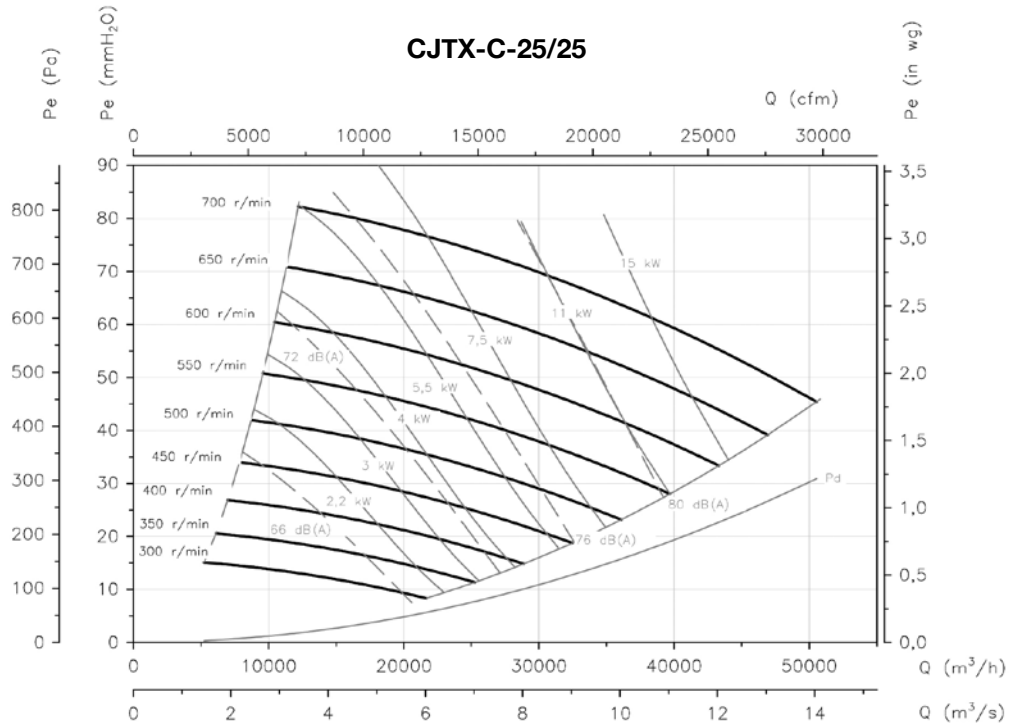

CJSX

Unidades de extracción 400 °C/2h, a transmisión con ventilador de simple aspiración



Unidades de extracción 400 °C/2h con motor fuera del paso del aire. Para trabajar en el exterior de la zona de riesgo de incendios.

Ventilador:

- Estructura en chapa de acero galvanizado.
- Turbina a acción en chapa de acero galvanizado.
- Homologación según norma EN 12101-3, con certificación n°: 0370-CPR-0503.

Motor:

- Motores clase F con rodamientos a bolas y protección IP55.
- Motores con eficiencia IE3 para potencias iguales o superiores a 0,75 kW, excepto monofásicos, 2 velocidades y 8 polos.

- Trifásico 230/400 V 50 Hz (hasta 4 kW) y 400/690 V 50 Hz (potencias superiores a 4 kW).
- Temperatura máxima del aire a transportar: Servicio S1 -25 °C +120 °C en continuo. Servicio S2 300 °C/2h y 400 °C/2h.

Acabado:

- Anticorrosivo en chapa de acero galvanizado.

Bajo demanda:

- Extractores con motor de 2 velocidades.
- Extractores con salida vertical.

Código de pedido

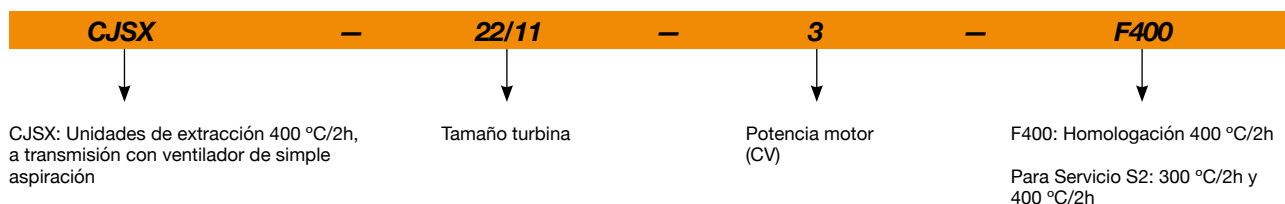

Características técnicas

Modelo	Velocidad (r/min)	Intensidad máxima admisible (A)			Potencia instalada (kW)	Caudal máximo (m³/h)	Nivel presión sonora dB (A)	Peso aprox. (Kg)
		230V	400V	690V				
CJSX-12/6-0.75	1000	2,92	1,69		0,55	2600	68	73
CJSX-12/6-1 IE3	1100	2,82	1,62		0,75	3100	72	74
CJSX-12/6-1.5 IE3	1250	4,07	2,34		1,10	3500	75	77
CJSX-12/6-2 IE3	1300	5,41	3,11		1,50	4250	76	80
CJSX-12/6-3 IE3	1500	7,93	4,56		2,20	4800	79	85
CJSX-15/7-1 IE3	800	2,82	1,62		0,75	4000	66	92
CJSX-15/7-1.5 IE3	850	4,07	2,34		1,10	4800	69	95
CJSX-15/7-2 IE3	920	5,41	3,11		1,50	5400	71	98
CJSX-15/7-3 IE3	1000	7,93	4,56		2,20	6400	74	103
CJSX-15/7-4 IE3	1050	10,70	6,15		3,00	7400	76	106
CJSX-18/9-1.5 IE3	750	4,07	2,34		1,10	5800	68	111
CJSX-18/9-2 IE3	790	5,41	3,11		1,50	6600	70	114
CJSX-18/9-3 IE3	800	7,93	4,56		2,20	8200	73	119
CJSX-18/9-4 IE3	850	10,70	6,15		3,00	9000	76	122

Características técnicas

Modelo	Velocidad (r/min)	Intensidad máxima admisible (A)			Potencia instalada (kW)	Caudal máximo (m³/h)	Nivel presión sonora dB (A)	Peso aprox. (Kg)
		230V	400V	690V				
CJSX-18/9-5.5 IE3	920	13,90	8,00		4,00	10500	80	125
CJSX-20/10-2 IE3	650	5,41	3,11		1,50	8100	66	203
CJSX-20/10-3 IE3	690	7,93	4,56		2,20	10100	69	208
CJSX-20/10-4 IE3	750	10,70	6,15		3,00	11500	72	211
CJSX-20/10-5.5 IE3	790	13,90	8,00		4,00	13100	73	214
CJSX-20/10-7.5 IE3	850		10,30	5,97	5,50	15000	75	227
CJSX-22/11-3 IE3	580	7,93	4,56		2,20	11200	67	219
CJSX-22/11-4 IE3	610	10,70	6,15		3,00	13000	69	222
CJSX-22/11-5.5 IE3	650	13,90	8,00		4,00	15000	71	225
CJSX-22/11-7.5 IE3	690		10,30	5,97	5,50	17000	73	238
CJSX-22/11-10 IE3	750		13,90	8,06	7,50	19000	75	246
CJSX-22/11-15 IE3	830		20,90	12,10	11,00	22000	77	273
CJSX-22/11-20 IE3	910		27,90	16,20	15,00	24500	79	292
CJSX-22/11-25 IE3	1000		35,10	20,30	18,50	26000	81	322
CJSX-25/13-4 IE3	520	10,70	6,15		3,00	14000	61	254
CJSX-25/13-5.5 IE3	550	13,90	8,00		4,00	17000	64	257
CJSX-25/13-7.5 IE3	590		10,30	5,97	5,50	19500	68	270
CJSX-25/13-10 IE3	620		13,90	8,06	7,50	23000	70	278
CJSX-25/13-15 IE3	690		20,90	12,10	11,00	26500	72	305
CJSX-25/13-20 IE3	750		27,90	16,20	15,00	29500	74	324
CJSX-25/13-25 IE3	810		35,10	20,30	18,50	32000	76	354
CJSX-30/14-5.5 IE3	400	13,90	8,00		4,00	21000	69	331
CJSX-30/14-7.5 IE3	425		10,30	5,97	5,50	24000	72	344
CJSX-30/14-10 IE3	460		13,90	8,06	7,50	27500	75	352
CJSX-30/14-15 IE3	500		20,90	12,10	11,00	33000	77	379
CJSX-30/14-20 IE3	550		27,90	16,20	15,00	36500	79	398
CJSX-30/14-25 IE3	600		35,10	20,30	18,50	38000	80	428



Erp. (Energy Related Products)

Información de la Directiva 2009/125/EC descargable desde la web de SODECA o programa de selección QuickFan

Accesorios



INT



IAT



C2V



RPA



B



BD



BIC



ACE ACE/400



CABLE BOX



AET



CENTRAL CO



VSD3/A-RFT
- VSD1/A-RFM



TEJ



VIS

Dimensiones mm

Suministro standard impulsión horizontal (H) RD 90

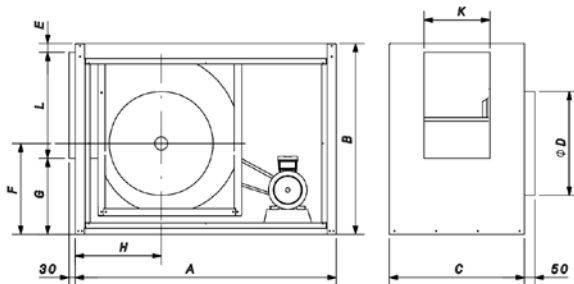

Bajo demanda impulsión horizontal (H) LG 90

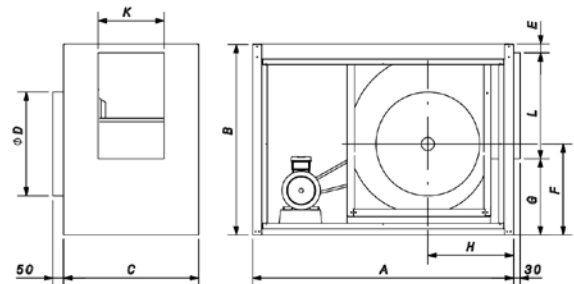

	A	B	C	ØD	E	F	G	H	K	L
CJSX-12/6-H	853	653	543	317	44	315	262	306	215	347
CJSX-15/7-H	1003	758	600	400	49	357	299	337	273	410
CJSX-18/9-H	1203	878	621	480	42	418	348	396	304	488
CJSX-20/10-H	1426	1105	729	582	91	491	407	429	334	607
CJSX-22/11-H	1573	1253	763	625	61	540	492	458	362	700
CJSX-25/13-H	1653	1286	821	703	62	579	425	479	416	799
CJSX-30/14-H	1868	1521	860	804	54	699	528	575	478	939

Bajo demanda impulsión vertical (V) RD 0

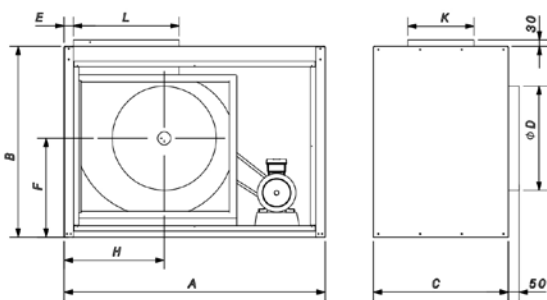

Bajo demanda impulsión vertical (V) LG 0

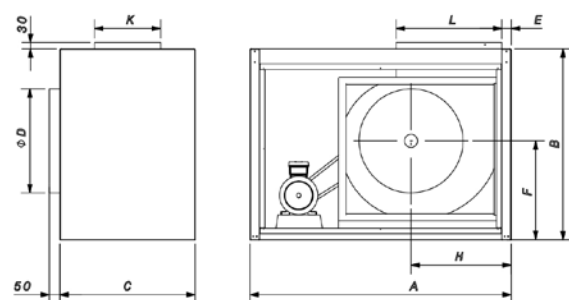

	A	B	C	ØD	E	F	H	K	L
CJSX-12/6-V	853	653	543	317	45	348	339	215	347
CJSX-15/7-V	1003	758	600	400	27	398	379	273	410
CJSX-18/9-V	1203	878	621	480	43	455	462	304	488
CJSX-20/10-V	1426	1105	729	582	91	555	615	334	607
CJSX-22/11-V	1573	1253	763	625	61	614	633	362	700
CJSX-25/13-V	1653	1286	821	703	62	700	707	416	799
CJSX-30/14-V	1868	1521	860	804	65	788	843	478	939

Curvas características

Q= Caudal en m³/h, m³/s y cfm

Pe= Presión estática en mmH₂O, Pa e inwg

CJSX-12/6

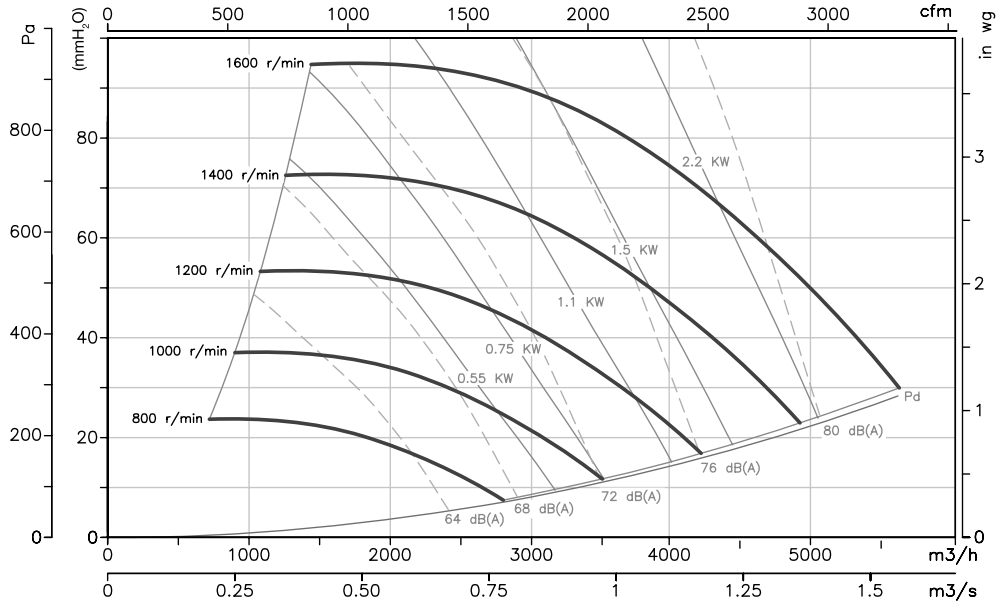

CJSX-15/7

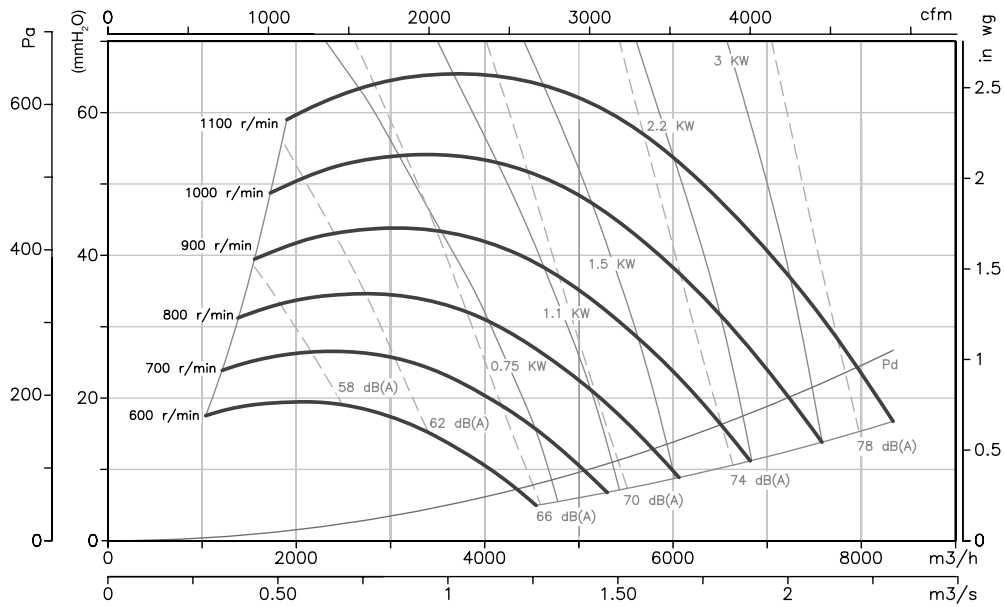

Curvas características

Q= Caudal en m³/h, m³/s y cfm

Pe= Presión estática en mmH₂O, Pa e inwg

CJSX-18/9

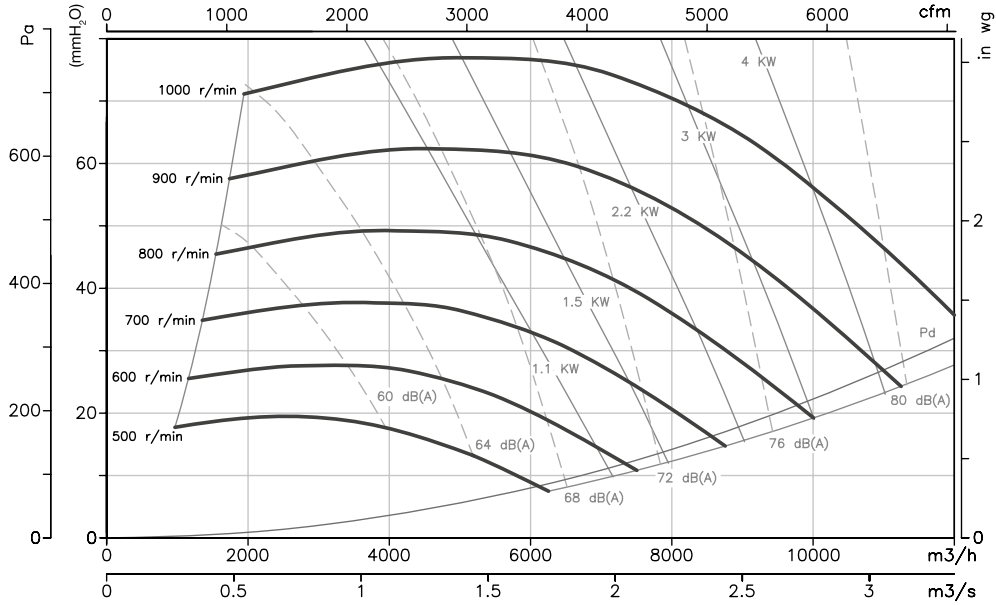

CJSX-20/10

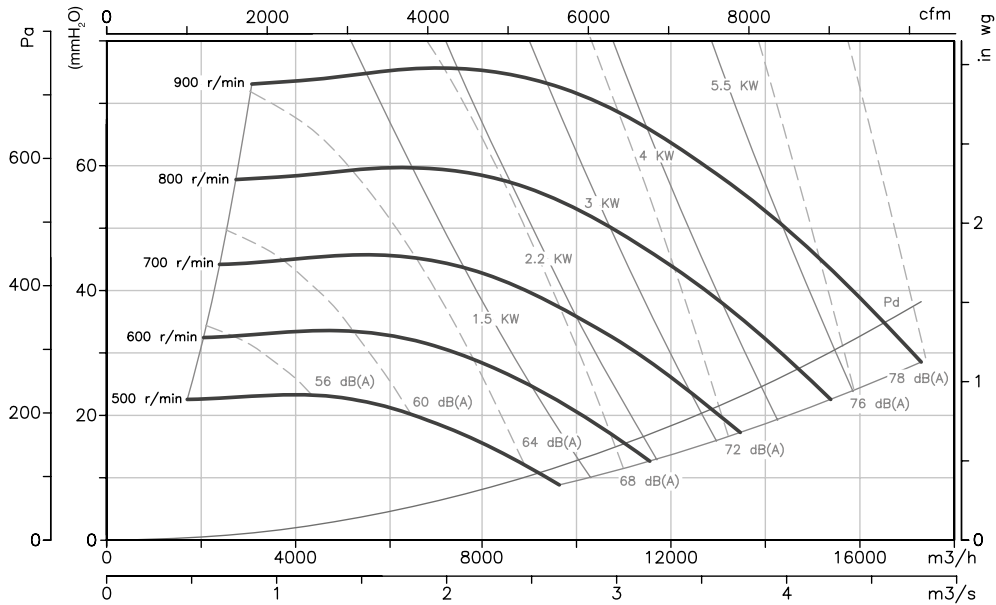

Curvas características

Q= Caudal en m³/h, m³/s y cfm

Pe= Presión estática en mmH₂O, Pa e inwg

CJSX-22/11

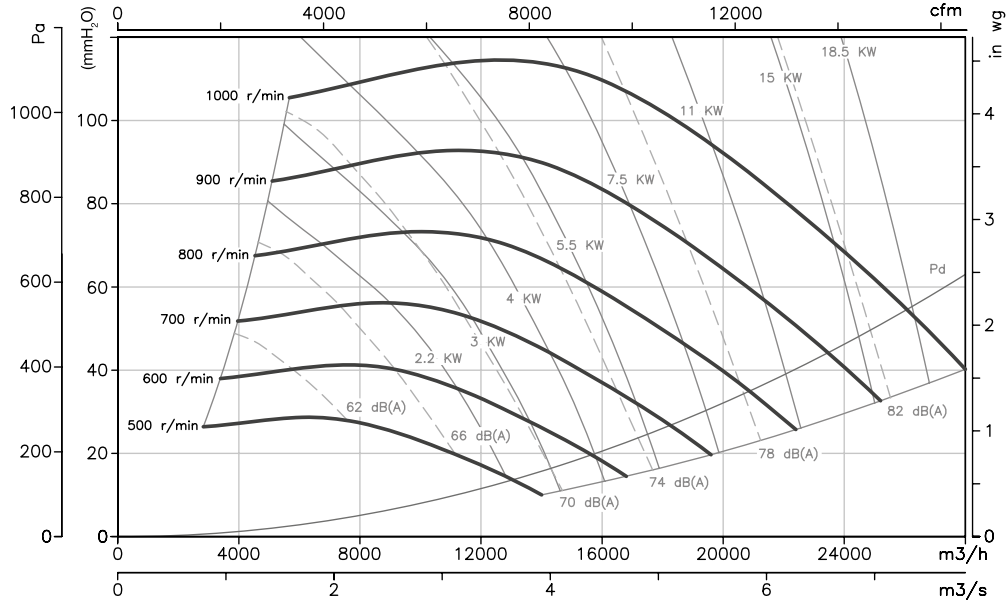

CJSX-25/13

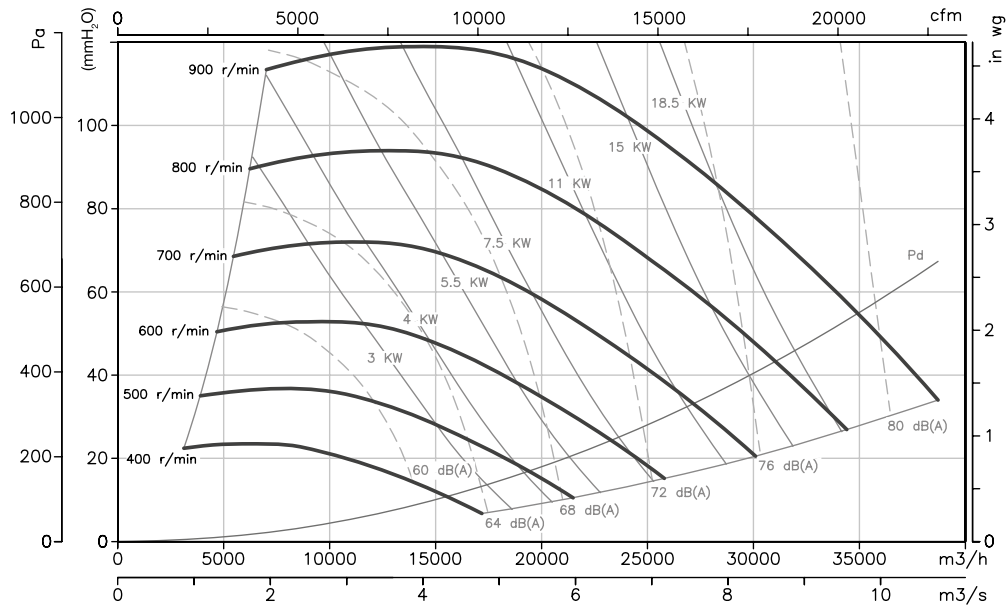

Curvas características

Q= Caudal en m³/h, m³/s y cfm

Pe= Presión estática en mmH₂O, Pa e inwg

CJSX-30/14

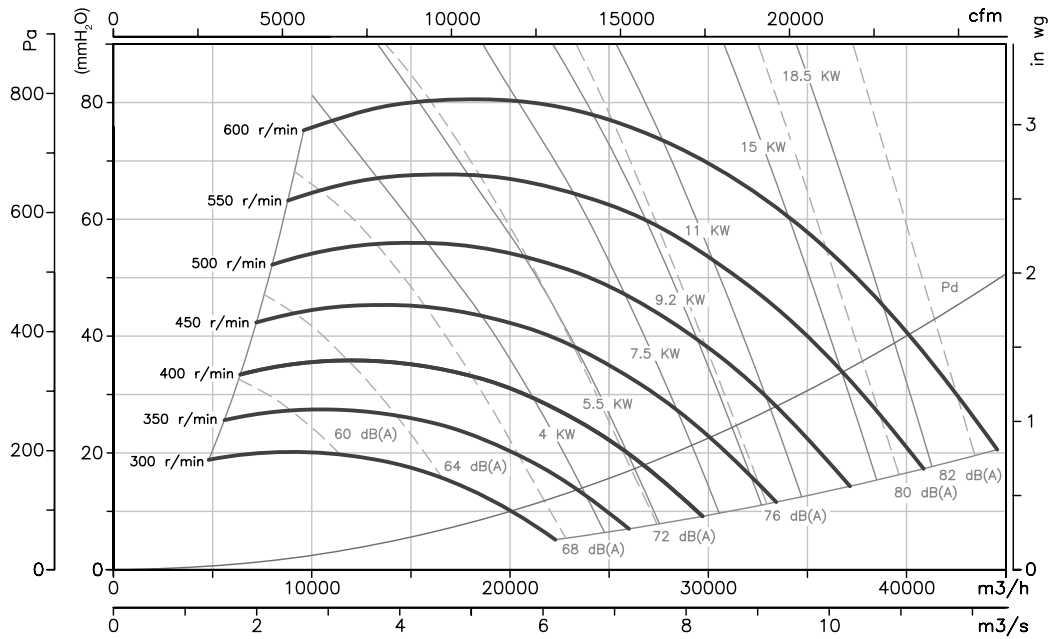

CJSRX



Unidades de extracción 400 °C/2h para trabajar en el exterior de la zona de riesgo de incendios, accionados a transmisión con turbina a reacción



Unidades de extracción 400 °C/2h, accionados a transmisión con turbina a reacción equipados con motor eléctrico, conjunto de poleas, correas y protectores normalizados según norma ISO-13857.

Ventilador:

- Envoltente en chapa de acero.
- Turbina a reacción en chapa de acero.
- Homologación según norma EN 12101-3, con certificación nº: 0370-CPR-1578.
- Conjunto de poleas, correas y protectores normalizados según norma ISO-13857.
- Temperatura máxima del aire a transportar: -25 °C +150 °C.

Motor:

- Motores con eficiencia IE3 para potencias iguales o superiores a 0,75 kW, excepto monofásicos, 2 velocidades y 8 polos.
- Motores clase F con rodamientos a bolas y protección IP55.
- Trifásico 230/400 V 50 Hz (hasta 4 kW) y 400/690 V 50 Hz (potencias superiores a 4 kW).
- Temperatura de trabajo: -25 °C +50 °C.

Acabado:

- Anticorrosivo en chapa de acero galvanizado.

Bajo demanda:

- Bobinados especiales para diferentes tensiones.

Código de pedido

CJSRX	-	710	-	10	-	F400
↓		↓		↓		↓
CJSRX: Unidades de extracción 400 °C/2h para trabajar en el exterior de la zona de riesgo de incendios, accionados a transmisión con turbina a reacción		Tamaño turbina		Potencia motor (CV)		F400: Homologación 400 °C/2h

Características técnicas

Modelo	Velocidad (r/min)	Intensidad máxima admisible (A)			Potencia instalada (kW)	Caudal máximo (m³/h)	Nivel presión sonora dB (A)	Peso aprox. (Kg)
		230V	400V	690V				
CJSRX-315-1 IE3	2095	2,82	1,62		0,75	3430	64	111
CJSRX-315-1.5 IE3	2375	4,07	2,34		1,10	3880	68	119
CJSRX-315-2 IE3	2655	5,41	3,11		1,50	4340	70	124
CJSRX-315-3 IE3	3000	7,93	4,56		2,20	4910	73	129
CJSRX-355-0.75	1580	2,92	1,69		0,55	3680	63	126
CJSRX-355-1 IE3	1765	2,82	1,62		0,75	4120	67	127
CJSRX-355-1.5 IE3	2010	4,07	2,34		1,10	4690	70	135
CJSRX-355-2 IE3	2225	5,41	3,11		1,50	5190	73	140
CJSRX-355-3 IE3	2530	7,93	4,56		2,20	5900	75	144
CJSRX-355-4 IE3	2860	10,70	6,15		3,00	6680	78	150
CJSRX-400-1 IE3	1465	2,82	1,62		0,75	4860	61	155
CJSRX-400-1.5 IE3	1665	4,07	2,34		1,10	5520	65	160
CJSRX-400-2 IE3	1845	5,41	3,11		1,50	6110	67	171
CJSRX-400-3 IE3	2100	7,93	4,56		2,20	6960	70	172
CJSRX-400-4 IE3	2370	10,70	6,15		3,00	7850	73	174
CJSRX-400-5.5 IE3	2610	13,90	8,00		4,00	8640	75	181
CJSRX-450-1 IE3	1220	2,82	1,62		0,75	5620	63	186

Características técnicas

Modelo	Velocidad (r/min)	Intensidad máxima admisible (A)			Potencia instalada (kW)	Caudal máximo (m³/h)	Nivel presión sonora dB (A)	Peso aprox. (Kg)
		230V	400V	690V				
CJSRX-450-1.5 IE3	1390	4,07	2,34		1,10	6400	68	189
CJSRX-450-2 IE3	1540	5,41	3,11		1,50	7100	70	200
CJSRX-450-3 IE3	1750	7,93	4,56		2,20	8060	73	201
CJSRX-450-4 IE3	1980	10,70	6,15		3,00	9120	76	203
CJSRX-450-5.5 IE3	2180	13,90	8,00		4,00	10040	78	210
CJSRX-450-7.5 IE3	2420		10,30	5,97	5,50	11150	80	253
CJSRX-450-10 IE3	2670		13,90	8,06	7,50	12300	82	229
CJSRX-500-1.5 IE3	1140	4,07	2,34		1,10	7330	66	228
CJSRX-500-2 IE3	1270	5,41	3,11		1,50	8160	70	238
CJSRX-500-3 IE3	1445	7,93	4,56		2,20	9290	75	240
CJSRX-500-4 IE3	1635	10,70	6,15		3,00	10510	77	246
CJSRX-500-5.5 IE3	1800	13,90	8,00		4,00	11570	79	252
CJSRX-500-7.5 IE3	2000		10,30	5,97	5,50	12860	82	291
CJSRX-500-10 IE3	2220		13,90	8,06	7,50	14270	84	267
CJSRX-500-15 IE3	2300		20,90	12,10	11,00	14780	85	321
CJSRX-560-2 IE3	1035	5,41	3,11		1,50	9880	63	304
CJSRX-560-3 IE3	1185	7,93	4,56		2,20	11360	68	299
CJSRX-560-4 IE3	1340	10,70	6,15		3,00	12880	71	306
CJSRX-560-5.5 IE3	1475	13,90	8,00		4,00	14210	74	312
CJSRX-560-7.5 IE3	1640		10,30	5,97	5,50	15830	76	351
CJSRX-560-10 IE3	1815		13,90	8,06	7,50	17560	78	327
CJSRX-560-15 IE3	2065		20,90	12,10	11,00	20010	81	381
CJSRX-630-3 IE3	1010	7,93	4,56		2,20	12120	66	339
CJSRX-630-4 IE3	1140	10,70	6,15		3,00	13680	69	345
CJSRX-630-5.5 IE3	1255	13,90	8,00		4,00	15060	71	351
CJSRX-630-7.5 IE3	1395		10,30	5,97	5,50	16740	73	390
CJSRX-630-10 IE3	1550		13,90	8,06	7,50	18600	76	366
CJSRX-630-15 IE3	1760		20,90	12,10	11,00	21120	78	420
CJSRX-630-20 IE3	1900		27,90	16,20	15,00	22800	80	442
CJSRX-710-4 IE3	960	10,70	6,15		3,00	17060	66	416
CJSRX-710-5.5 IE3	1060	13,90	8,00		4,00	18840	69	422
CJSRX-710-7.5 IE3	1180		10,30	5,97	5,50	20980	71	461
CJSRX-710-10 IE3	1305		13,90	8,06	7,50	23200	73	456
CJSRX-710-15 IE3	1485		20,90	12,10	11,00	26400	76	491
CJSRX-710-20 IE3	1670		27,90	16,20	15,00	29690	78	513
CJSRX-710-25 IE3	1750		35,10	20,30	18,50	31110	79	546



Erp. (Energy Related Products)

Información de la Directiva 2009/125/EC descargable desde la web de SODECA o programa de selección QuickFan

Accesorios



INT



IAT



C2V



RPA



B



BD



BIC



ACE ACE/400



CABLE BOX



AET



CENTRAL CO



VSD3/A-RFT
- VSD1/A-RFM

Dimensiones mm

Suministro standard impulsión horizontal
(H) RD 90

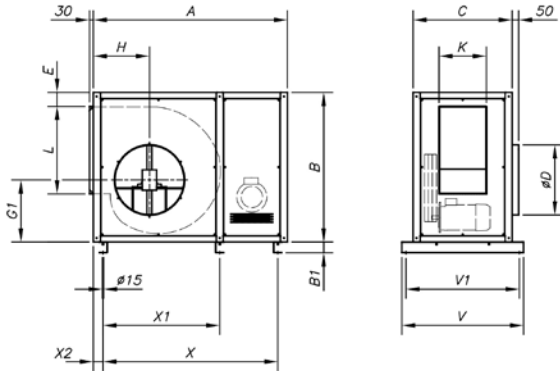

Bajo demanda impulsión horizontal
(H) LG 90

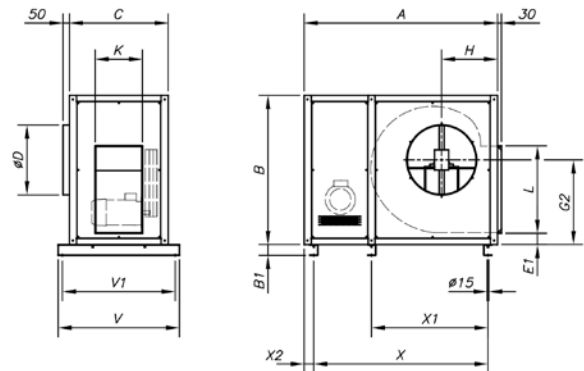

Bajo demanda impulsión vertical
(V) RD 0

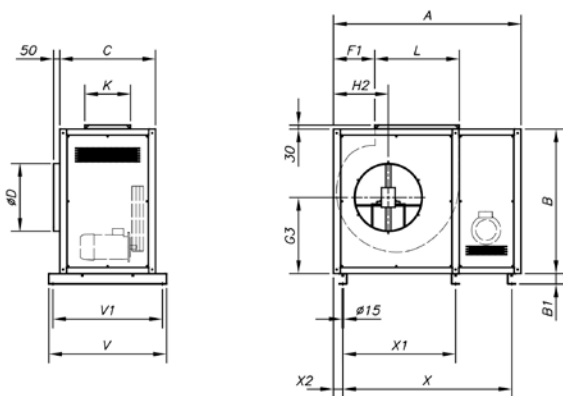

Bajo demanda impulsión vertical
(V) LG 0

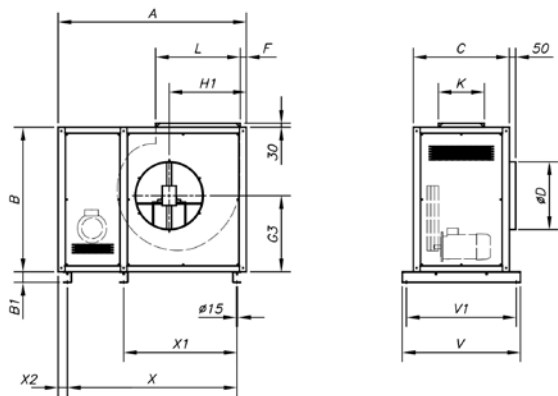

	A	B	B1	C	ØD	E	E1	F	F1	G1	G2	G3
CJSRX-315	1170	740	60	600	315	82	84,2	113	281	317,5	423,2	366,2
CJSRX-355	1265	815	60	650	365	85	86,5	112,5	302,5	347,2	470	398
CJSRX-400	1370	900	60	680	400	82	90,2	111	331	386,2	522,2	447,2
CJSRX-450	1480	990	60	716	448	82	91,2	112,8	360	422,2	577,2	491
CJSRX-500	1625	1080	60	760	510	80,5	91	111,7	381,3	461,2	629,2	534,2
CJSRX-560	1760	1195	60	810	580	86,8	94,2	128	426	506,2	696,2	590
CJSRX-630	1880	1322	60	850	635	85,2	89,6	113,4	455,6	557,7	768,7	648,2
CJSRX-710	2180	1500	80	910	710	103	108,2	100	491	632,2	873,2	737,2

	H	H1	H2	K	L	V	V1	X	X1	X2
CJSRX-315	305	451,5	346,3	224	405	760	680	880	-	155
CJSRX-355	338	496	373	248	454	810	730	1020	-	152
CJSRX-400	359	543	407	275	508	840	760	1120	-	152
CJSRX-450	383	598	443	309	570	876	796	1240	-	152
CJSRX-500	409	650	482	345	639	920	840	1340	670	152
CJSRX-560	462	731	540	384	716	970	890	1490	745	152
CJSRX-630	488	792,5	578,5	433	802	1010	930	1610	820	158
CJSRX-710	562	865	624	479	899	1070	990	1910	955	168

Curvas características

Q= Caudal en m³/h, m³/s y cfm

Pe= Presión estática en mmH₂O, Pa e inwg

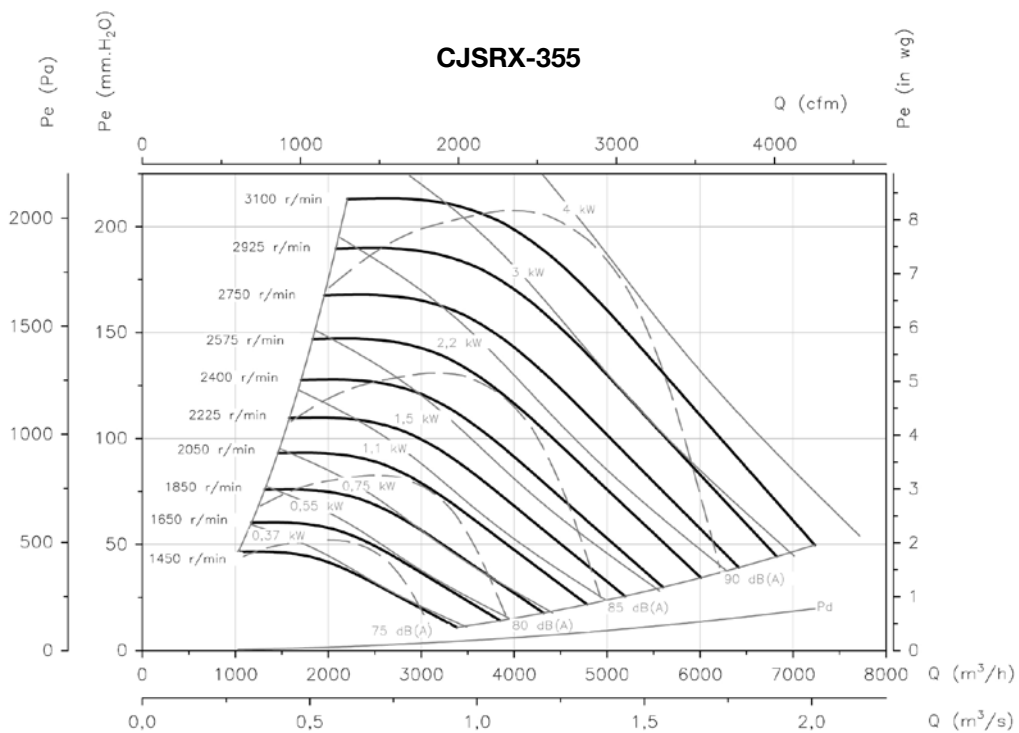
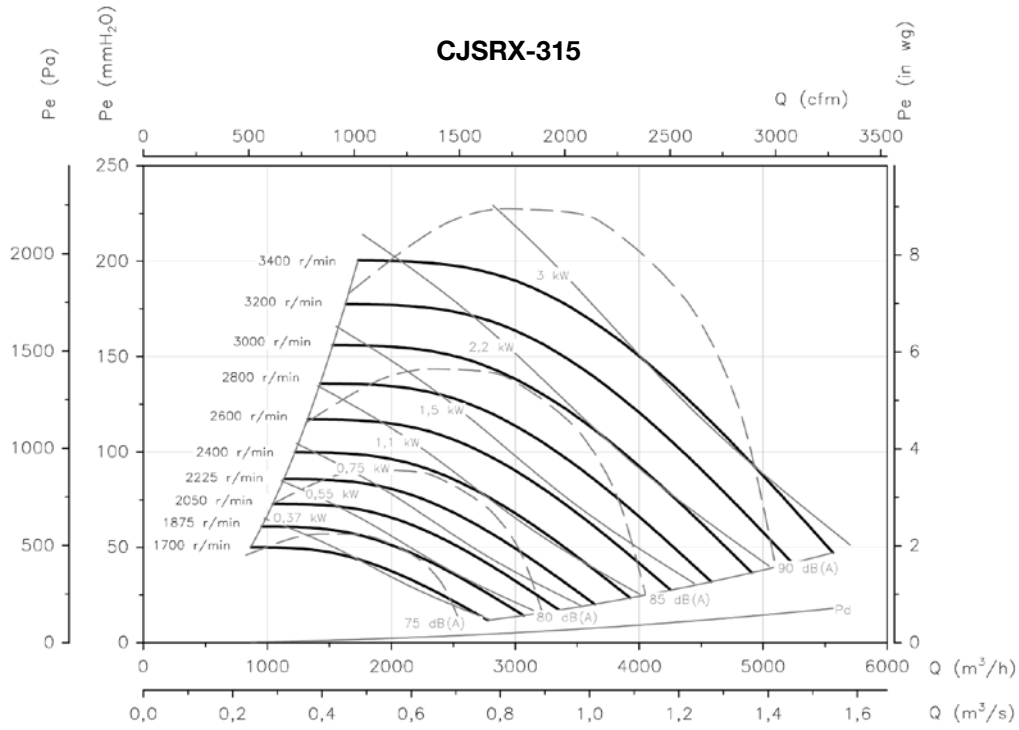

Curvas características

Q= Caudal en m³/h, m³/s y cfm

Pe= Presión estática en mmH₂O, Pa e inwg

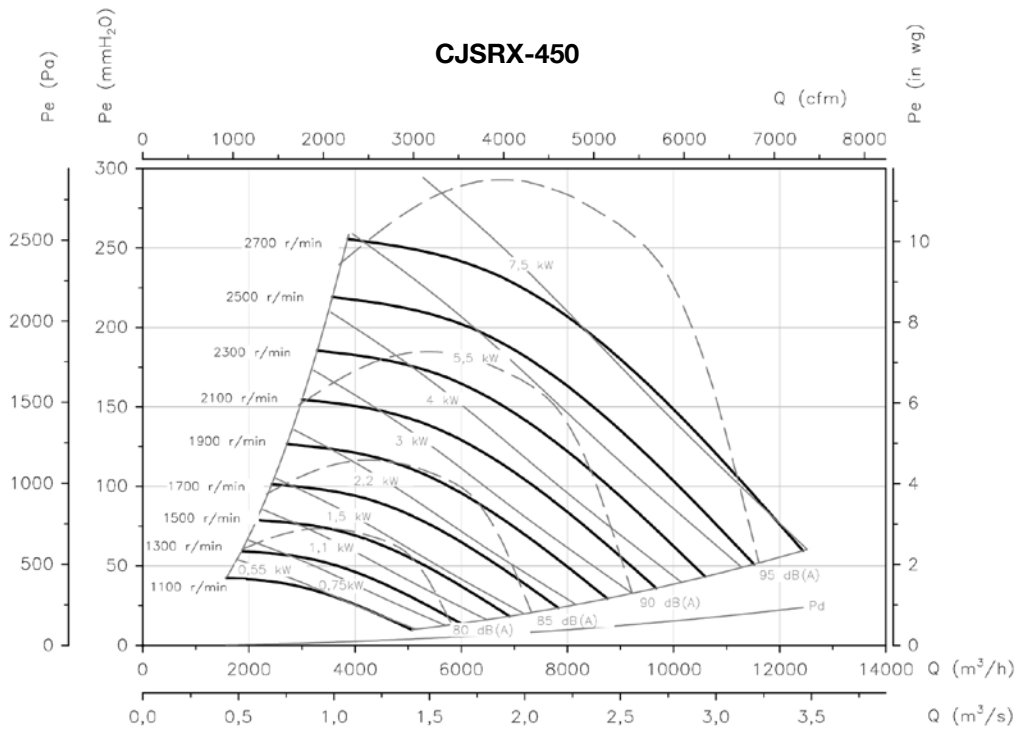
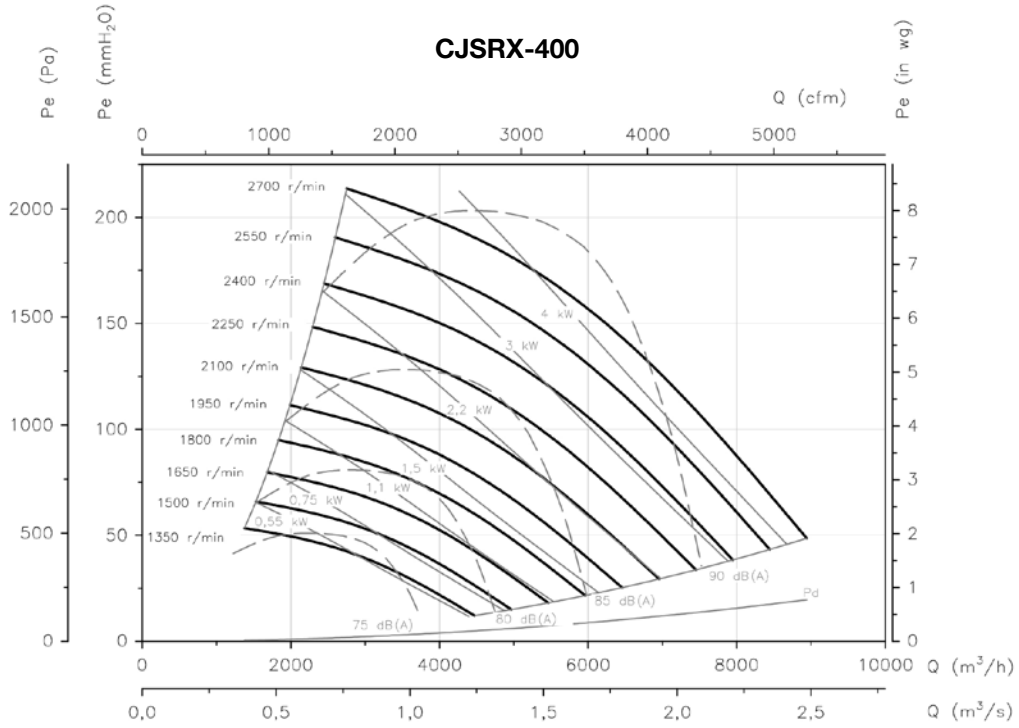

Curvas características

Q= Caudal en m³/h, m³/s y cfm

Pe= Presión estática en mmH₂O, Pa e inwg

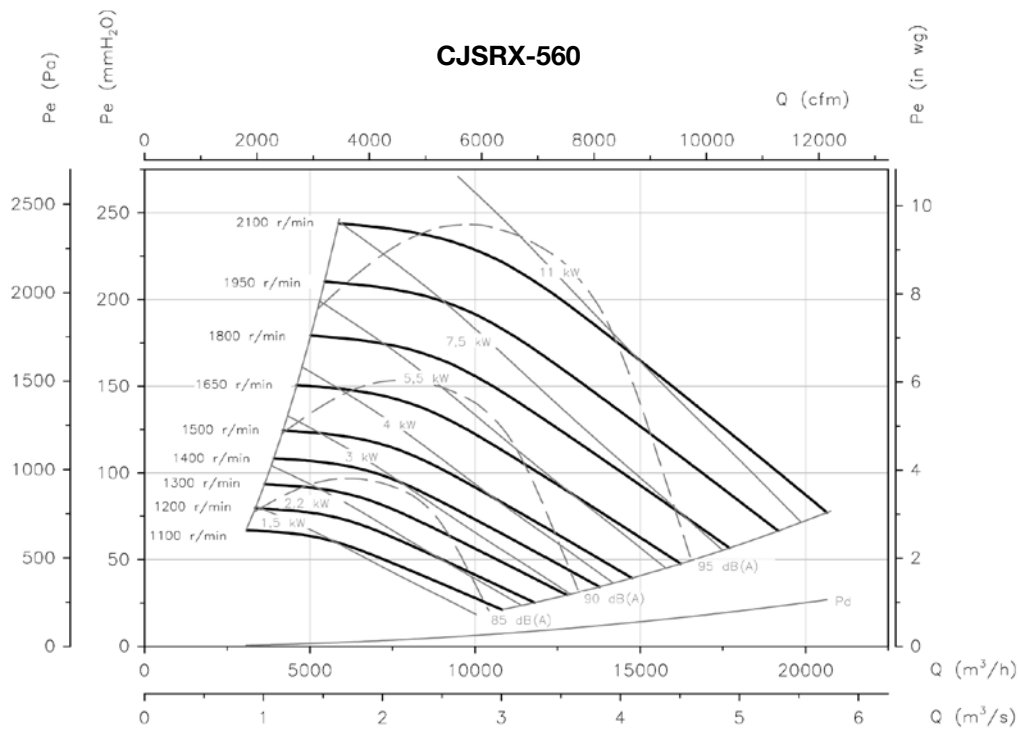
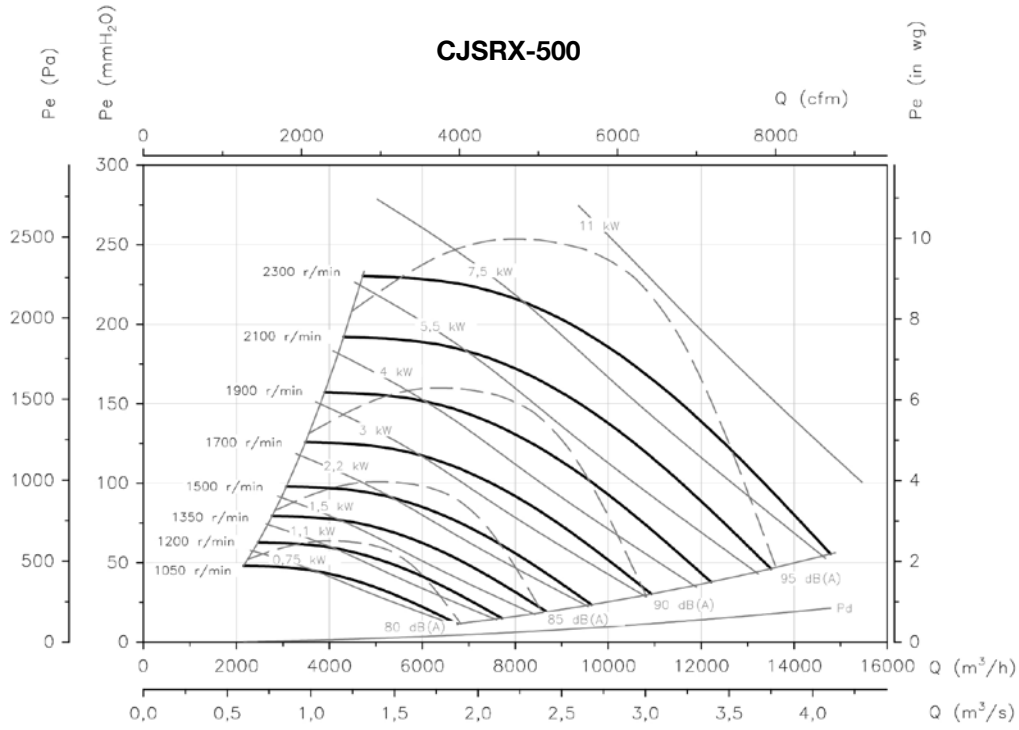

Curvas características

Q= Caudal en m³/h, m³/s y cfm

Pe= Presión estática en mmH₂O, Pa e inwg

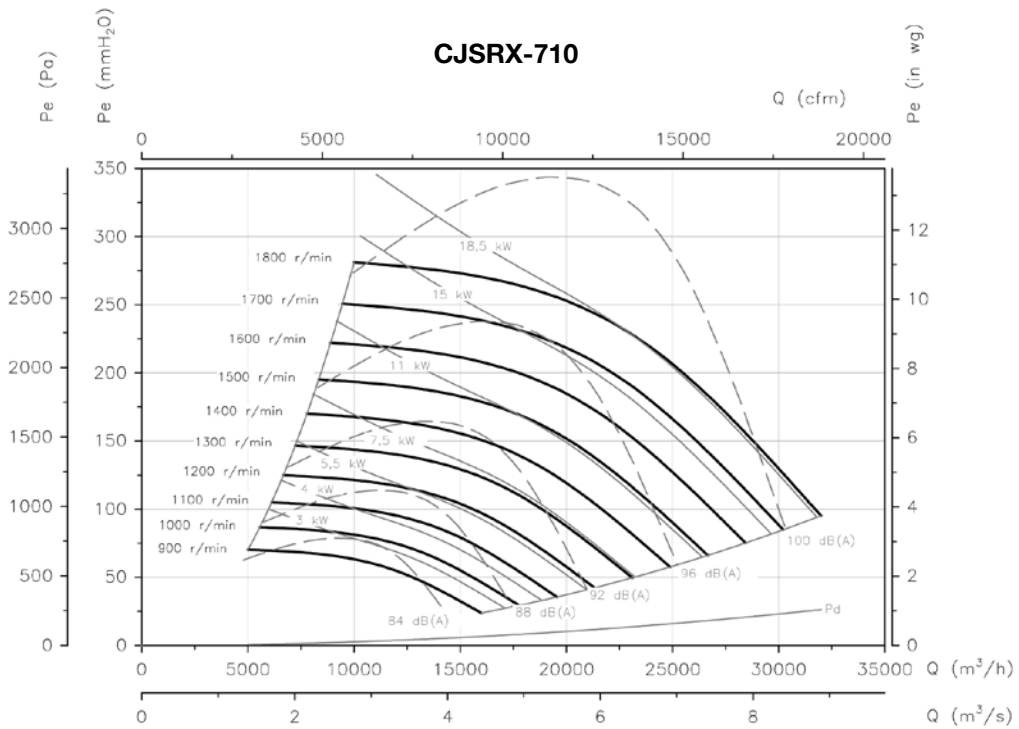
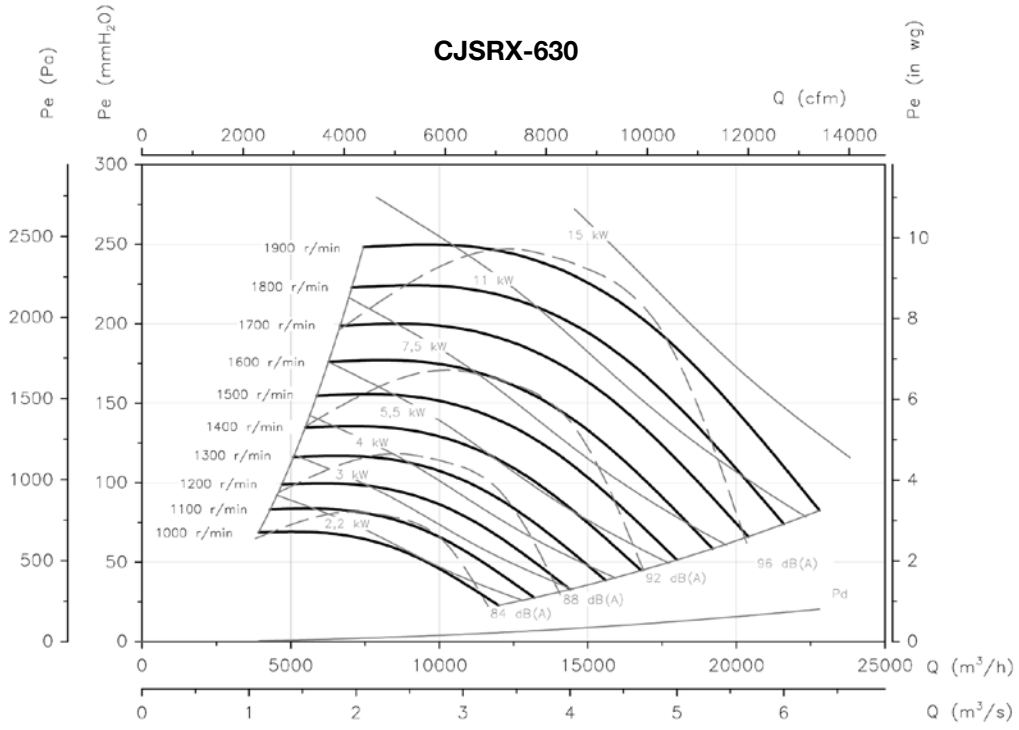

CJLINE

Unidades de extracción de aire y humo a 400 °C/2h, con entrada y salida lineal



Unidades de extracción en línea 400 °C/2h y 120 °C en continuo, para trabajar en el exterior de la zona de riesgo de incendio.

Ventilador:

- Estructura en chapa de acero galvanizado.
- Turbina a reacción en chapa de acero.
- Homologación según norma EN 12101-3, con certificación n°: 0370-CPR-0594.
- Dirección aire sentido lineal.

Motor:

- Motores clase F con rodamientos a bolas, protección IP55, de 1 o 2 velocidades según modelo.
- Motores con eficiencia IE3 para potencias iguales o superiores a 0,75 kW, excepto monofásicos, 2 velocidades y 8 polos.

- Trifásico 230/400 V 50 Hz (hasta 4 kW) y 400/690 V 50 Hz (potencias superiores a 4 kW).
- Temperatura máxima del aire a transportar: Servicio S1 -20 °C +120 °C en continuo. Servicio S2 300 °C/2h y 400 °C/2h.

Acabado:

- Anticorrosivo en chapa de acero galvanizado.

Bajo demanda:

- Extractores con motor de 2 velocidades.

Código de pedido

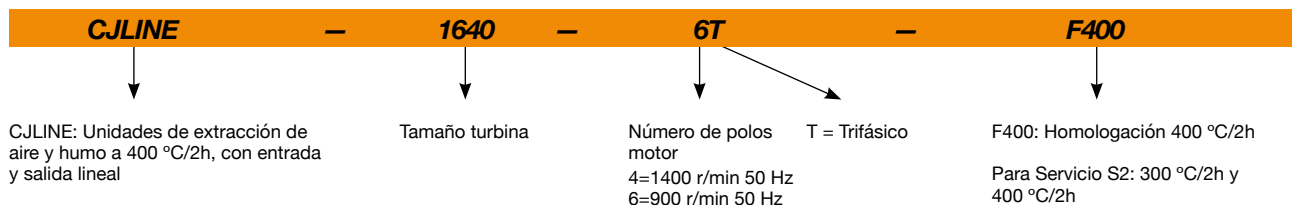

Características técnicas

Modelo	Velocidad (r/min)	Intensidad máxima admisible (A)			Potencia instalada (kW)	Caudal máximo (m³/h)	Nivel presión sonora dB (A)	Peso aprox. (Kg)
		230V	400V	690V				
CJLINE-1131-4T	1350	1,66	0,96		0,25	2000	47	58
CJLINE-1235-4T	1350	1,66	0,96		0,25	2820	54	62
CJLINE-1640-4T	1380	2,92	1,69		0,55	4450	59	76
CJLINE/H-1650-4T IE3	1440	5,41	3,11		1,50	9860	72	118
CJLINE-1845-4T IE3	1455	4,07	2,34		1,10	6290	63	87
CJLINE-1845-6T	900	2,24	1,30		0,37	4280	55	81
CJLINE/H-1856-4T IE3	1440	10,70	6,15		3,00	13590	78	170
CJLINE-1856-6T IE3	940	3,36	1,93		0,75	8100	60	135
CJLINE/H-2063-4T IE3	1465		10,30	5,97	5,50	22010	81	260
CJLINE-2063-6T IE3	940	3,36	1,93		0,75	9860	63	188
CJLINE-2271-6T IE3	950	6,43	3,70		1,50	13600	67	209
CJLINE-2880-6T IE3	970	12,00	6,91		3,00	22400	69	275



Erp. (Energy Related Products)

Información de la Directiva 2009/125/EC descargable desde la web de SODECA o programa de selección QuickFan

Características acústicas

Los valores indicados, se determinan mediante medidas de nivel de presión y potencia sonora en dB(A) obtenidas en campo libre a una distancia equivalente a dos veces la envergadura del ventilador más el diámetro de la turbina, con un mínimo de 1,5 m.

Espectro de potencia sonora Lw(A) en dB(A) por banda de frecuencia en Hz

	63	125	250	500	1000	2000	4000	8000		63	125	250	500	1000	2000	4000	8000
CJLINE-1131-4T	42	51	57	56	60	60	52	46	CJLINE/H-1856-4T	69	77	91	87	90	90	85	71
CJLINE-1235-4T	49	58	64	63	67	66	59	53	CJLINE-1856-6T	58	64	69	70	73	72	65	60
CJLINE-1640-4T	56	62	67	68	71	73	65	59	CJLINE/H-2063-4T	81	86	93	94	93	90	83	75
CJLINE/H-1650-4T	64	74	82	84	83	85	76	66	CJLINE-2063-6T	60	66	72	72	76	76	68	61
CJLINE-1845-4T	60	66	71	72	75	77	69	63	CJLINE-2271-6T	64	70	76	76	80	80	72	65
CJLINE-1845-6T	52	58	63	64	67	69	61	55	CJLINE-2880-6T	66	72	78	78	82	82	74	67

Dimensiones mm

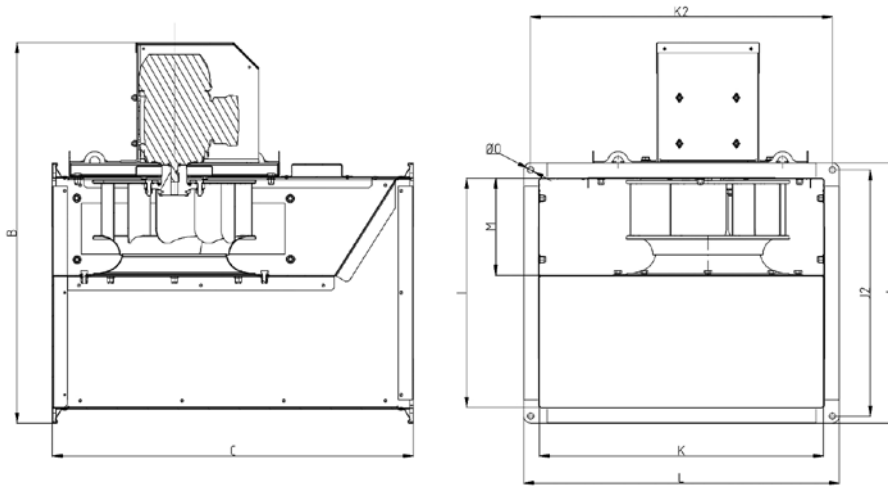

	B	C	I	J	J2	K	K2	L	M	ØO
CJLINE-1131	750	710	450	510	483	560	593	620	195	12
CJLINE-1235	797	800	500	560	533	620	653	680	223	12
CJLINE-1640	896	900	560	620	593	711	743	770	245	12
CJLINE/H-1650	1015	1000	630	690	663	800	833	860	338	12
CJLINE-1845	1015	1000	630	690	663	800	833	860	278	12
CJLINE-1856	1185	1250	800	860	833	1000	1033	1060	348	12
CJLINE/H-1856	1220	1250	800	860	833	1000	1033	1060	348	12
CJLINE-2063	1295	1400	900	980	940	1125	1165	1205	410	14
CJLINE/H-2063	1480	1400	900	980	940	1125	1165	1205	410	14
CJLINE-2271	1350	1400	900	980	940	1190	1230	1270	470	14
CJLINE-2880	1580	1500	1000	1080	1040	1250	1290	1330	510	14

Curvas características

Q= Caudal en m³/h, m³/s y cfm

Pe= Presión estática en mmH₂O, Pa e inwg

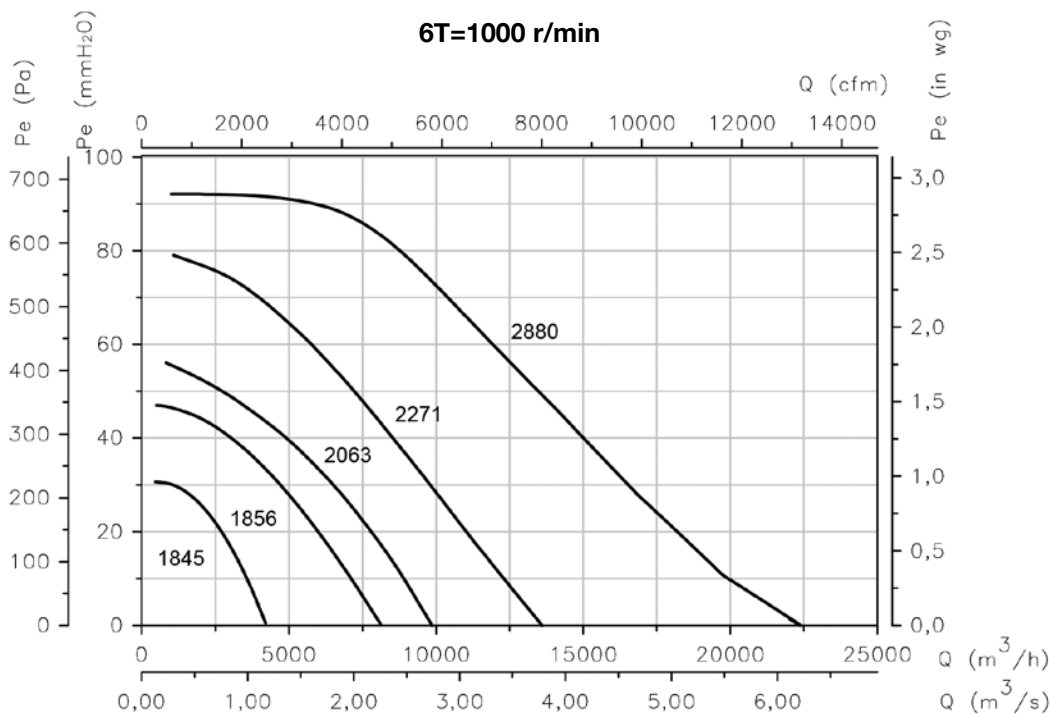
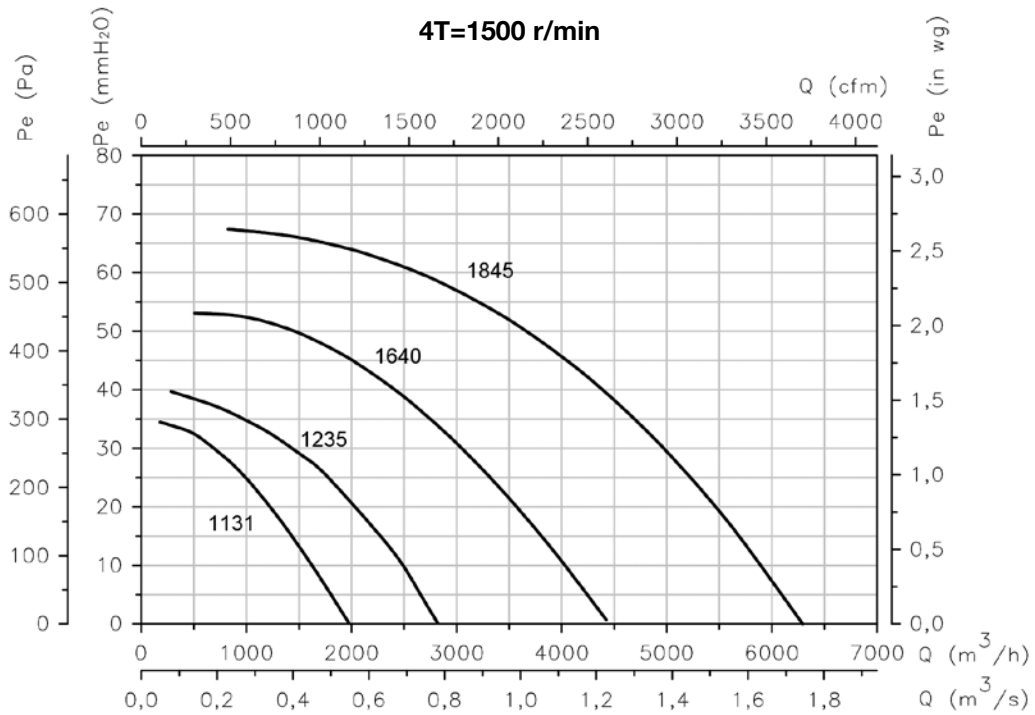

Curvas características

Q= Caudal en m³/h, m³/s y cfm

Pe= Presión estática en mmH₂O, Pa e inwg

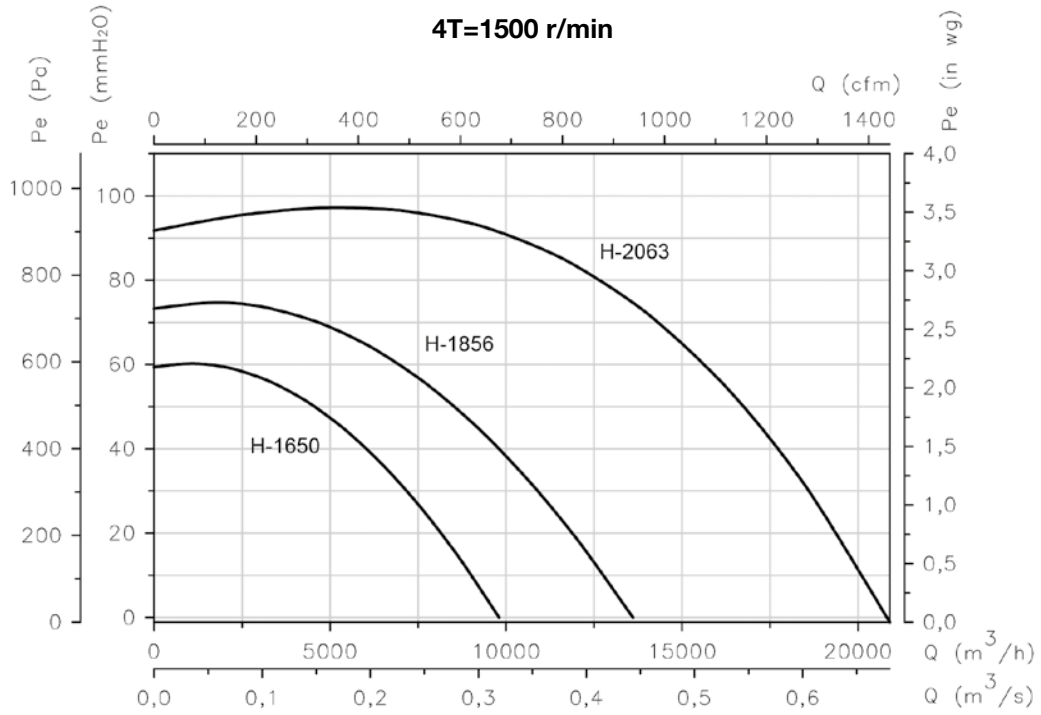

Accesorios



INT



CABLE BOX



C2V



VSD3/A-RFT
- VSD1/A-RFM



CENTRAL CO



AET



VIS



TAC

CJLINE/EC

Unidades de extracción de aire con entrada y salida lineal, equipadas con motor EC Technology IE5



Unidades de extracción de aire con entrada y salida lineal, equipadas con motor EC Technology IE5 con electrónica integrada.

Ventilador:

- Estructura en chapa de acero galvanizado.
- Turbina a reacción en chapa de acero.
- Dirección aire sentido lineal.

Motor:

- Motores EC Technology de alta eficiencia con electrónica integrada, regulables mediante 0-10 V o 4-20 mA.
- Motores con eficiencia IE5, clase F y protección IP55.
- Monofásico 230 V 50/60 Hz.
- Temperatura de trabajo: -20 °C +60 °C.

EC CONTROL: Se suministra como accesorio opcional. Cuadro de control para sistemas de ventilación con motores EC Technology que lleven la electrónica integrada en el propio motor. Con las siguientes características:

- CPC: Control de presión constante.
- CFC: Control de caudal constante.
- DAY/NIGHT: Ajuste de doble consigna de presión según momento del día.
- Sensor externo: Compatible con sensor de temperatura, humedad, calidad de aire o CO.
- Equipo preconfigurado en modo presión constante con set point de 100 Pa.

Acabado:

- Anticorrosivo en chapa de acero galvanizado.



MOTOR EC TECHNOLOGY con electrónica integrada



EC CONTROL Suministro como accesorio opcional

Código de pedido

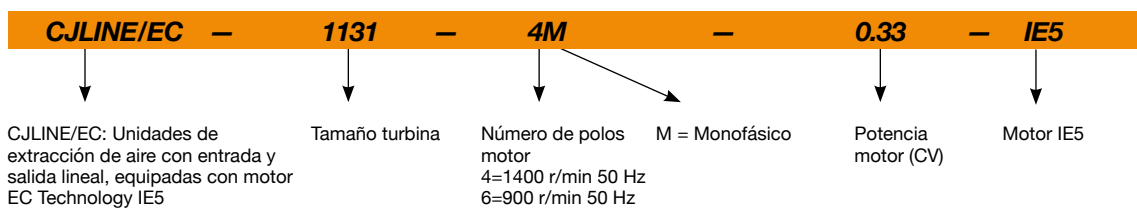

Características técnicas

Modelo	Velocidad (r/min)	Intensidad máxima admisible (A) 230V	Potencia eléctrica máx. (kW)	Caudal máximo (m ³ /h)	Nivel de presión sonora dB (A)	Peso aprox. (Kg)
CJLINE/EC-1131-4M-0.33 IE5	1370	2,3	0,25	1980	51	42
CJLINE/EC-1235-4M-0.33 IE5	1370	2,3	0,25	2820	56	54
CJLINE/EC-1640-4M-0.75 IE5	1385	4,8	0,55	4430	61	76
CJLINE/EC-1845-4M-1.5 IE5	1455	8,9	1,10	6300	65	87
CJLINE/EC-1856-6M-1 IE5	945	4,3	0,75	8100	59	135
CJLINE/EC-2063-6M-1 IE5	945	4,3	0,75	9900	61	188



Erp. (Energy Related Products)

Información de la Directiva 2009/125/EC descargable desde la web de SODECA o programa de selección QuickFan

Características acústicas

Los valores indicados, se determinan mediante medidas de nivel de presión y potencia sonora en dB(A) obtenidas en campo libre a una distancia equivalente a dos veces la envergadura del ventilador más el diámetro de la turbina, con un mínimo de 1,5 m.

Espectro de potencia sonora Lw(A) en dB(A) por banda de frecuencia en Hz

	63	125	250	500	1000	2000	4000	8000
CJLINE/EC-1131-4M	42	51	57	56	60	60	52	46
CJLINE/EC-1235-4M	49	58	64	63	67	66	59	53
CJLINE/EC-1640-4M	56	62	67	68	71	73	65	59
CJLINE/EC-1845-4M	60	66	71	72	75	77	69	63
CJLINE/EC-1856-6M	58	64	69	70	73	72	65	60
CJLINE/EC-2063-6M	60	66	72	72	76	76	68	61

Dimensiones mm

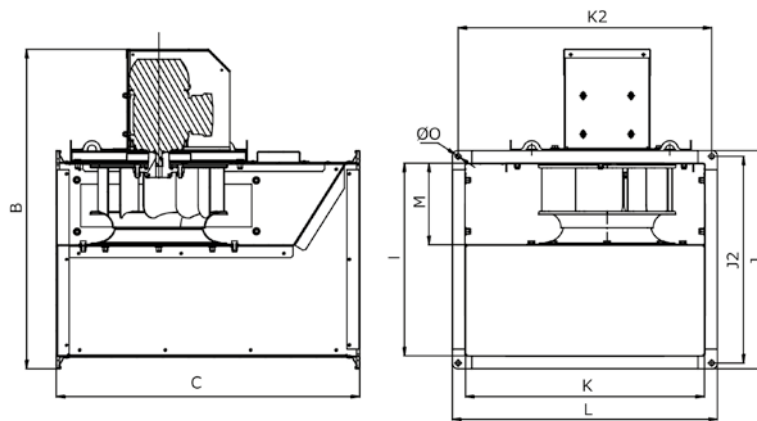

	B	C	I	J	J2	K	K2	L	M2	ØO
CJLINE/EC-1131-4M	783	710	451	510	483	561	593	620	194	12
CJLINE/EC-1235-4M	833	800	501	560	533	621	653	680	222	12
CJLINE/EC-1640-4M	896	900	561	620	593	711	743	770	244	12
CJLINE/EC-1845-4M	965	1000	631	690	663	801	833	860	277	12
CJLINE/EC-1856-6M	1133	1250	801	860	833	1001	1033	1060	348	12
CJLINE/EC-2063-6M	1242	1400	900	980	940	1124	1165	1205	410	14

Accesorios



Curvas características

Q= Caudal en m³/h, m³/s y cfm

Pe= Presión estática en mmH₂O, Pa e inwg

CJLINE/EC-1131-4M

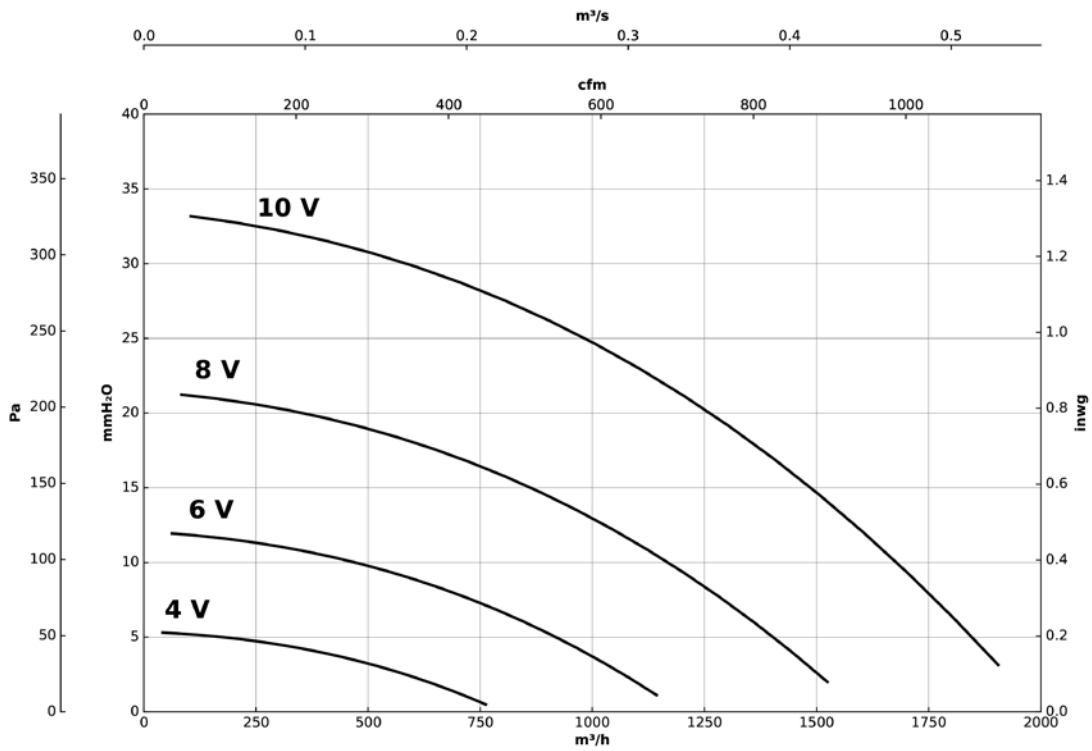

CJLINE/EC-1235-4M

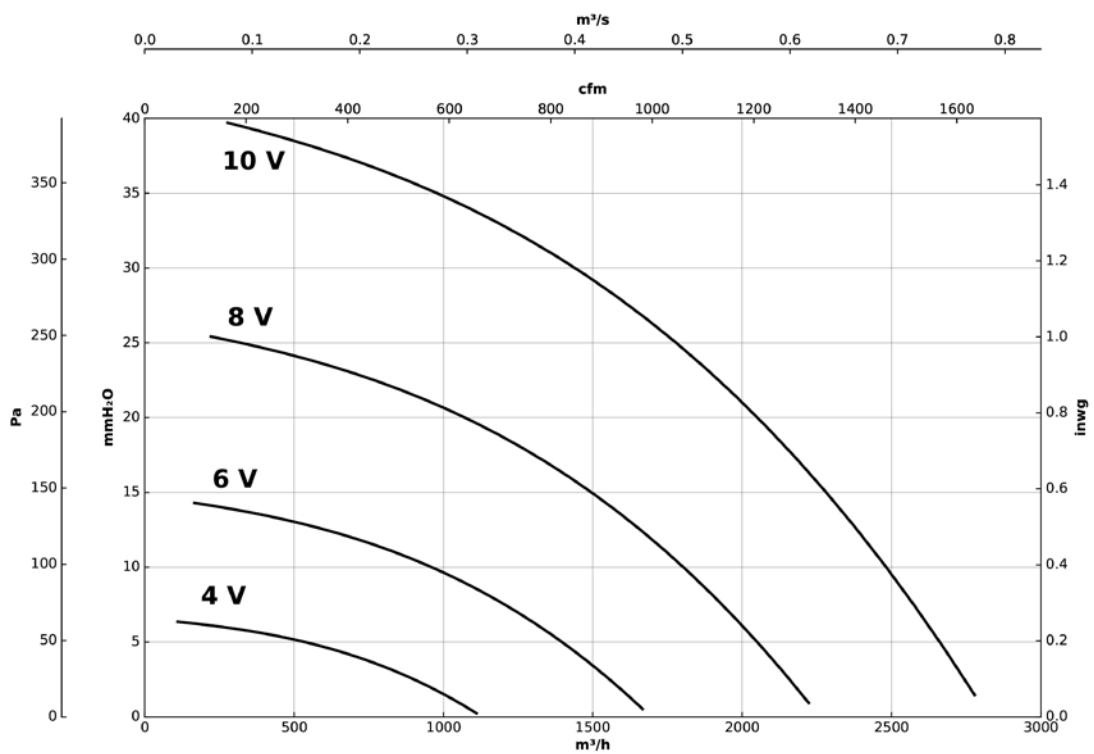

Curvas características

Q= Caudal en m³/h, m³/s y cfm

Pe= Presión estática en mmH₂O, Pa e inwg

CJLINE/EC-1640-4M

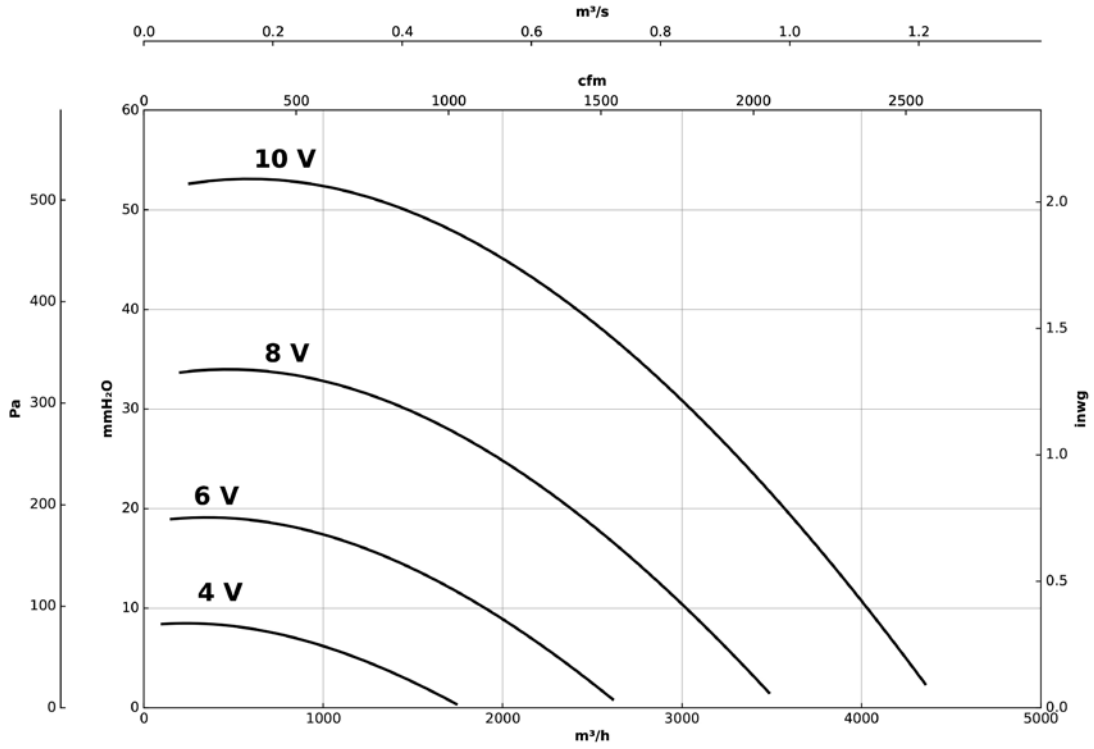

CJLINE/EC-1845-4M

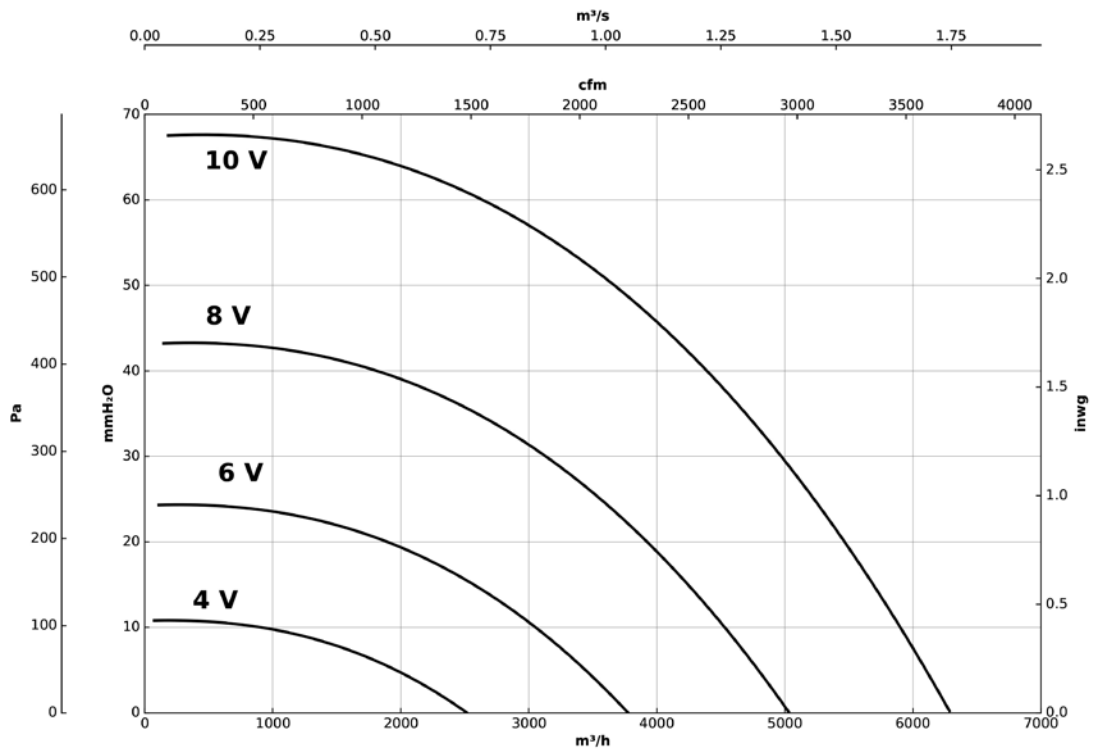

Curvas características

Q= Caudal en m³/h, m³/s y cfm

Pe= Presión estática en mmH₂O, Pa e inwg

CJLINE/EC-1856-6M

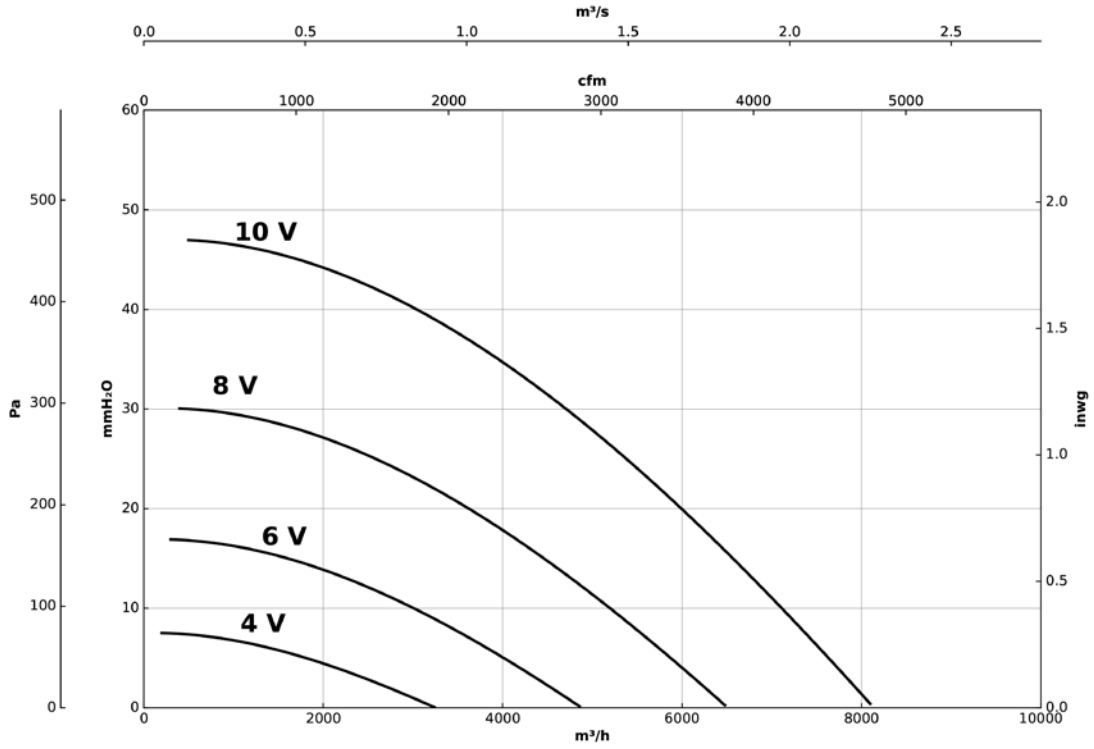

CJLINE/EC-2063-4M

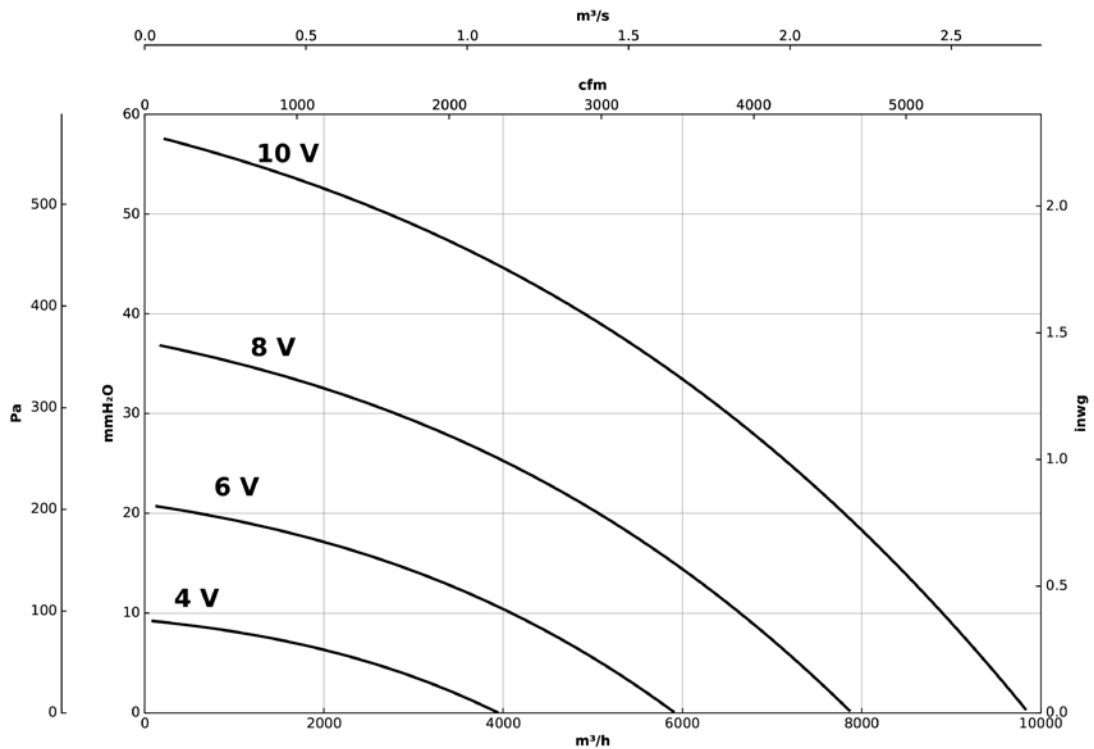

CKD



Unidades de extracción F400 con puerta de gran dimensión para poder realizar el mantenimiento con gran facilidad y aislamiento acústico de 40 mm



Ventilador:

- Estructura en chapa de acero galvanizado.
- Aislamiento acústico de 40 mm.
- Turbina a acción en chapa de acero galvanizado.
- Homologación según norma EN 12101-3, con certificación n°: 0370-CPR-2358.
- Dirección apertura puerta modificable gracias a sus bisagras intercambiables.
- Orientable en diferentes posiciones.
- Preparado para trabajo en continuo a 120 °C.
- Accesorio cubremotor (CM) incluido con el ventilador.

- Motores clase F con rodamientos a bolas y protección IP55.
- Monofásico 230 V 50 Hz y trifásico 230/400 V 50 Hz.
- Temperatura de trabajo: -25 °C +120 °C.

Acabado:

- Anticorrosivo en chapa de acero galvanizado.

Bajo demanda:

- Bobinados especiales para diferentes tensiones.

Motor:

- Motores con eficiencia IE3 para potencias iguales o superiores a 0,75 kW, excepto monofásicos, 2 velocidades y 8 polos.

Código de pedido

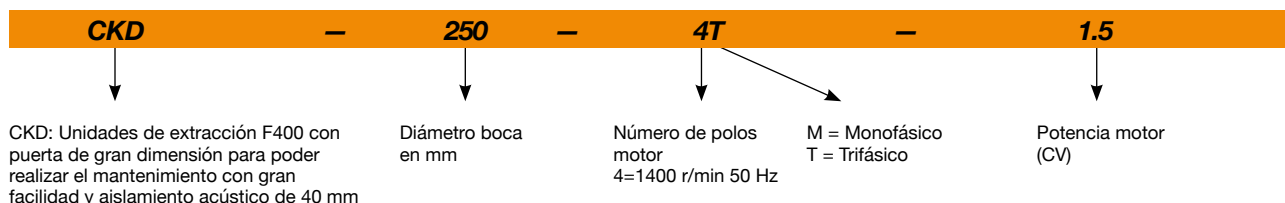

Características técnicas

Modelo	Velocidad (r/min)	Intensidad máxima admisible (A)		Potencia instalada (kW)	Caudal máximo (m³/h)	Nivel presión sonora dB (A)	Peso aprox. (Kg)
		230V	400V				
CKD-250-4T-1.5 IE3	1455	4,07	2,34	1,1	3160	69	48
CKD-280-4T-3 IE3	1435	7,93	4,56	2,2	4880	73	60



Erp. (Energy Related Products)

Información de la Directiva 2009/125/EC descargable desde la web de SODECA o programa de selección QuickFan

Características acústicas

Los valores indicados, se determinan mediante medidas de nivel de presión y potencia sonora en dB(A) obtenidas en campo libre a una distancia equivalente a dos veces la envergadura del ventilador más el diámetro de la turbina, con un mínimo de 1,5 m.

Espectro de potencia sonora Lw(A) en dB(A) por banda de frecuencia en Hz

	63	125	250	500	1000	2000	4000	8000
CKD-250-4	53	79	74	73	66	67	60	60
CKD-280-4	53	82	78	76	70	71	63	63

Dimensiones mm

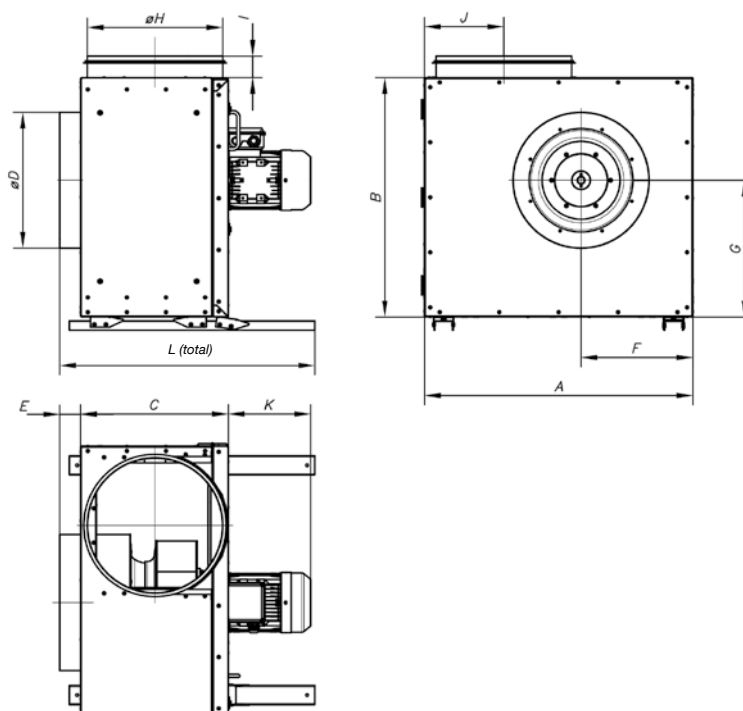

	A	B	C	ØD	E	F	G	ØH	I	J	K	L
CKD-250	590	520	260	250	50	245	290	250	48	160	225	560
CKD-280	590	520	275	315	50	245	290	250	48	160	287	600

Accesorios



INT



RM



VSD3/A-RFT
- VSD1/A-RFM

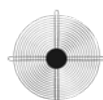

RT



BTUB



PT



ACE ACE/400

Curvas características

Q= Caudal en m³/h, m³/s y cfm

Pe= Presión estática en mmH₂O, Pa e inwg

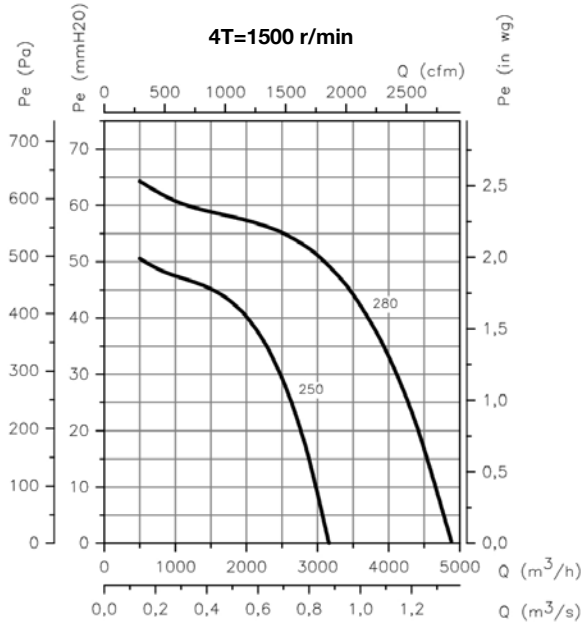

Orientaciones

Suministro standard: LG 0

Bajo demanda orientaciones LG 90 y LG 270. Se pueden obtener diferentes posiciones de montaje modificando los pies y bisagras intercambiables, de acuerdo a sus necesidades.

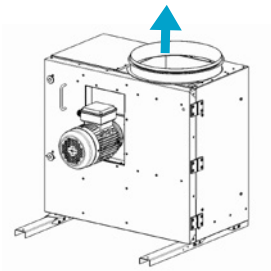

LG 0

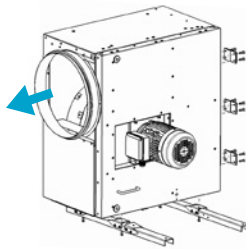

LG 90

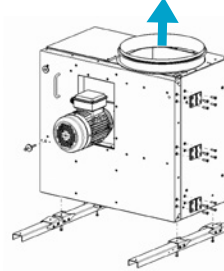

LG 0

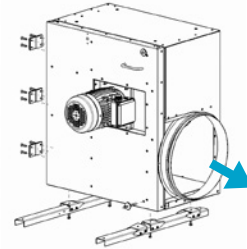

LG 270

Instalación

Los ventiladores CKD/CKDR pueden ser instalados en pared mediante escuadras.

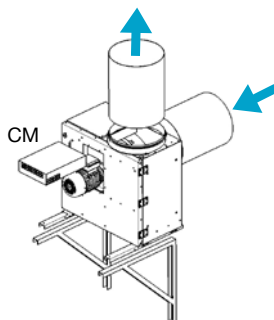

CKDR

Unidades de extracción F400 con puerta de gran dimensión para poder realizar el mantenimiento con gran facilidad y aislamiento acústico de 40 mm



Ventilador:

- Estructura en chapa de acero galvanizado.
- Aislamiento acústico de 40 mm.
- Turbina a reacción en chapa de acero.
- Homologación según norma EN 12101-3, con certificación nº: 0370-CPR-2358.
- Dirección apertura puerta modificable gracias a sus bisagras intercambiables.
- Orientable en diferentes posiciones.
- Preparado para trabajo en continuo a 120 °C.
- Accesorio cubremotor (CM) incluido con el ventilador.

- Motores clase F con rodamientos a bolas y protección IP55.
- Monofásico 230 V 50 Hz y trifásico 230/400 V 50 Hz.
- Temperatura de trabajo: -25 °C +120 °C.

Acabado:

- Anticorrosivo en chapa de acero galvanizado.

Bajo demanda:

- Bobinados especiales para diferentes tensiones.

Motor:

- Motores con eficiencia IE3 para potencias iguales o superiores a 0,75 kW, excepto monofásicos, 2 velocidades y 8 polos.

Código de pedido

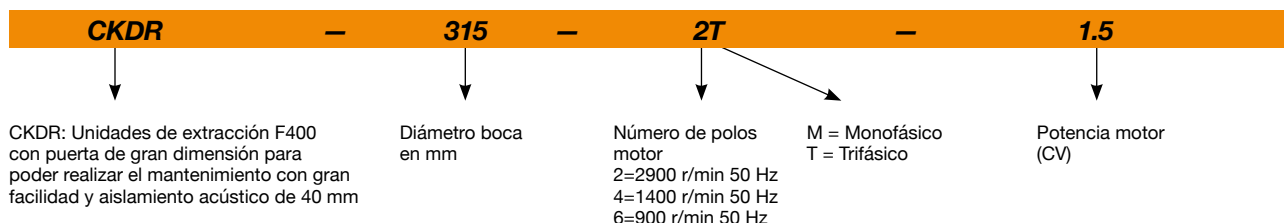

Características técnicas

Modelo	Velocidad (r/min)	Intensidad máxima admisible (A)		Potencia instalada (kW)	Caudal máximo (m³/h)	Nivel presión sonora dB (A)	Peso aprox. (Kg)
		230V	400V				
CKDR-280-2T-1 IE3	2825	2,80	1,62	0,75	2100	71	38
CKDR-315-2T-1.5 IE3	2830	4,03	2,34	1,10	3910	72	55
CKDR-355-4T-0.5	1370	2,02	1,17	0,37	2670	60	51
CKDR-355-4M-0.5	1420	2,90		0,37	2670	60	53
CKDR-400-4T-0.75	1380	2,92	1,69	0,55	3770	56	66
CKDR-400-4M-0.75	1450	4,40		0,55	3770	56	71
CKDR-450-4T-1 IE3	1420	2,82	1,62	0,75	5020	60	77
CKDR-450-4M-1	1410	5,05		0,75	5020	60	77
CKDR-500-4T-1.5 IE3	1455	4,07	2,34	1,10	7440	62	106
CKDR-560-4T-3 IE3	1435	7,93	4,56	2,20	11030	65	123

Características acústicas

Los valores indicados, se determinan mediante medidas de nivel de presión y potencia sonora en dB(A) obtenidas en campo libre a una distancia equivalente a dos veces la envergadura del ventilador más el diámetro de la turbina, con un mínimo de 1,5 m.

Espectro de potencia sonora Lw(A) en dB(A) por banda de frecuencia en Hz

	63	125	250	500	1000	2000	4000	8000		63	125	250	500	1000	2000	4000	8000
CKDR-280-2	53	67	73	74	76	77	73	71	CKDR-450-4	45	66	67	67	68	69	64	58
CKDR-315-2	50	67	77	77	79	79	74	71	CKDR-500-4	49	68	64	69	74	68	63	60
CKDR-355-4	43	62	64	65	68	67	61	55	CKDR-560-4	44	75	71	74	74	74	66	62
CKDR-400-4	41	60	62	63	65	64	58	53									

Dimensiones mm

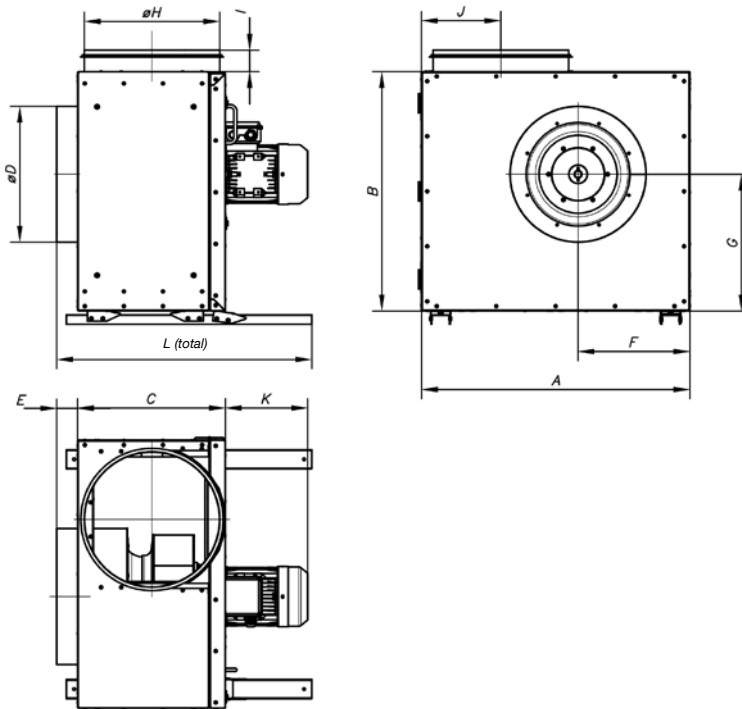

	A	B	C	$\varnothing D$	E	F	G	$\varnothing H$	I	J	K	L
CKDR-280	590	520	345	315	52	245	290	315	48	192,5	215	612
CKDR-315	700	625	385	355	55	290	356	355	56	207	215	665
CKDR-355	700	625	385	355	55	290	356	355	56	207	182	665
CKDR-400	830	775	385	355	55	354	418	355	56	212	214	660
CKDR-450	830	775	385	355	55	354	418	355	56	212	214	660
CKDR-500	1000	900	470	400	75	420	505	400	75	244	224	865
CKDR-560	1000	900	470	400	75	420	505	400	75	244	285	865

Curvas características

Q= Caudal en m³/h, m³/s y cfm

Pe= Presión estática en mmH₂O, Pa e inwg

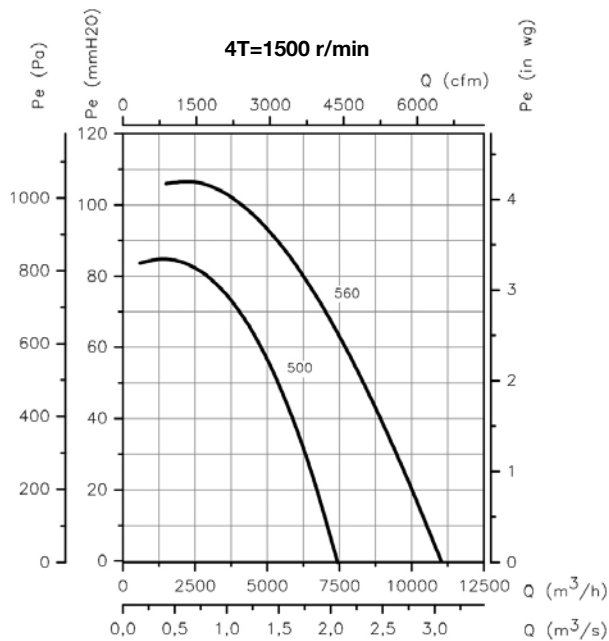
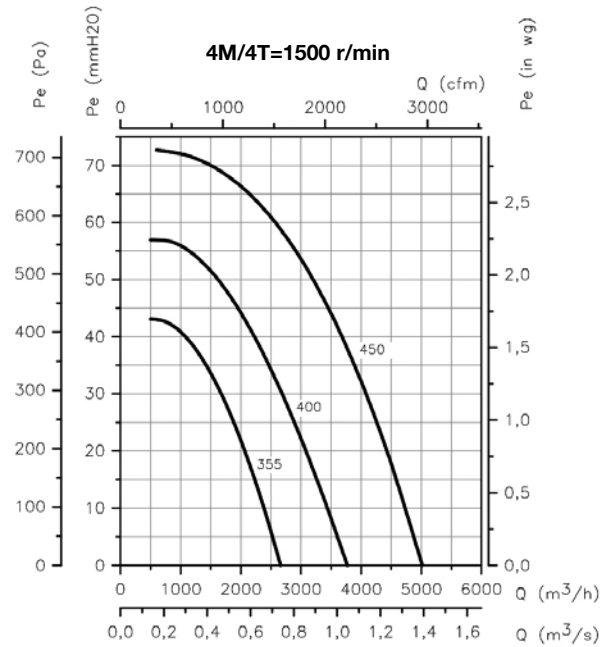
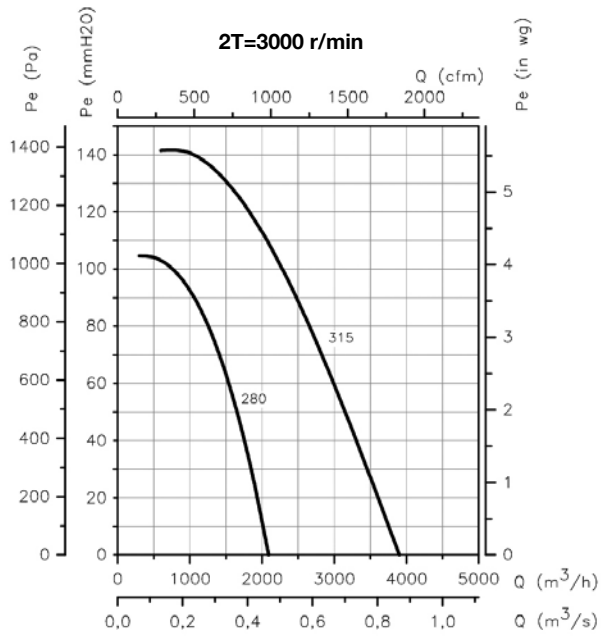

Orientaciones

Suministro standard: LG 0

Bajo demanda orientaciones LG 90 y LG 270. Se pueden obtener diferentes posiciones de montaje modificando los pies y bisagras intercambiables, de acuerdo a sus necesidades.

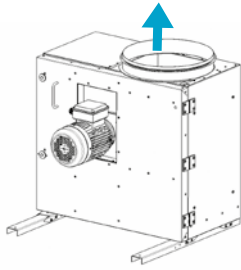

LG 0

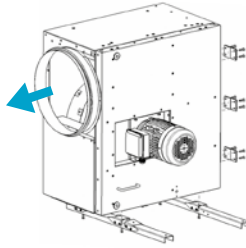

LG 90

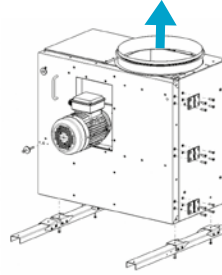

LG 0

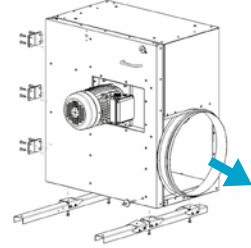

LG 270

Instalación

Los ventiladores CKD/CKDR pueden ser instalados en pared mediante escuadras.

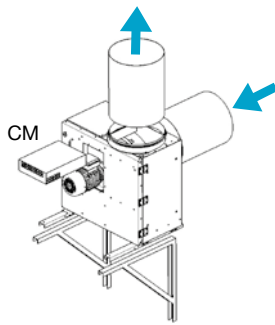

CM

Accesorios



INT



RM



VSD3/A-RFT
- VSD1/A-RFM

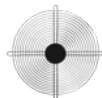

RT



BTUB



PT



ACE ACE/400

CKDR/EC

Unidades de extracción con puerta de gran dimensión y aislamiento acústico de 40 mm, equipadas con motor EC Technology IE5



MOTOR EC TECHNOLOGY con electrónica integrada



EC CONTROL Suministro como accesorio opcional

Unidades de extracción con puerta de gran dimensión para poder realizar el mantenimiento con gran facilidad y aislamiento acústico de 40 mm, equipadas con motor EC Technology IE5 con electrónica integrada.

Ventilador:

- Estructura en chapa de acero galvanizado.
- Aislamiento acústico de 40 mm.
- Turbina a reacción en chapa de acero.
- Dirección abertura puerta modificable gracias a sus bisagras intercambiables.
- Orientable en diferentes posiciones.
- Preparado para trabajo en continuo a 120 °C.
- Accesorio cubremotor (CM) incluido con el ventilador.

Motor:

- Motores EC Technology de alta eficiencia con electrónica integrada, regulables mediante 0-10 V o 4-20 mA.
- Motores con eficiencia IE5, clase F y protección IP55.
- Monofásico 230 V 50/60 Hz.
- Temperatura de trabajo: -25 °C +60 °C.

EC CONTROL: Se suministra como accesorio opcional. Cuadro de control para sistemas de ventilación con motores EC Technology que lleven la electrónica integrada en el propio motor. Con las siguientes características:

- CPC: Control de presión constante.
- CFC: Control de caudal constante.
- DAY/NIGHT: Ajuste de doble consigna de presión según momento del día.
- Sensor externo: Compatible con sensor de temperatura, humedad, calidad de aire o CO.
- Equipo preconfigurado en modo presión constante con set point de 100 Pa.

Acabado:

- Anticorrosivo en chapa de acero galvanizado.

Código de pedido

CKDR/EC – 280 – 2M – 1 – IE5

CKDR/EC: Unidades de extracción con puerta de gran dimensión y aislamiento acústico de 40 mm, equipadas con motor EC Technology IE5

Tamaño turbina

Número de polos motor
2=2900 r/min 50 Hz
4=1400 r/min 50 Hz

M = Monofásico

Potencia motor (CV)

Motor IE5

Características técnicas

Modelo	Velocidad	Intensidad máxima admisible (A)	Potencia eléctrica máx.	Caudal máximo	Nivel de presión sonora	Peso aprox.
	(r/min)	230V	(kW)	(m³/h)	dB (A)	(Kg)
CKDR/EC-280-2M-1 IE5	2825	5,9	0,75	2090	71	38
CKDR/EC-315-2M-1,5 IE5	2830	8,7	1,10	3900	72	55
CKDR/EC-355-4M-0.5 IE5	1400	3,4	0,37	2670	60	71
CKDR/EC-400-4M-0.75 IE5	1400	4,8	0,55	3770	56	71
CKDR/EC-450-4M-1 IE5	1410	5,8	0,75	5020	60	77
CKDR/EC-500-4M-1.5 IE5	1455	8,9	1,10	7440	62	106



Erp. (Energy Related Products)

Información de la Directiva 2009/125/EC descargable desde la web de SODECA o programa de selección QuickFan

Características acústicas

Los valores indicados, se determinan mediante medidas de nivel de presión y potencia sonora en dB(A) obtenidas en campo libre a una distancia equivalente a dos veces la envergadura del ventilador más el diámetro de la turbina, con un mínimo de 1,5 m.

Espectro de potencia sonora Lw(A) en dB(A) por banda de frecuencia en Hz

	63	125	250	500	1000	2000	4000	8000		63	125	250	500	1000	2000	4000	8000
CKDR/EC-280-2M-1	53	67	73	74	76	77	73	71	CKDR/EC-400-4M-0.75	41	60	62	63	65	64	58	53
CKDR/EC-315-2M-1,5	50	67	77	77	79	79	74	71	CKDR/EC-450-4M-1	45	66	67	67	68	69	64	58
CKDR/EC-355-4M-0.5	43	62	64	65	68	67	61	55	CKDR/EC-500-4M-1.5	49	68	64	69	74	68	63	60

Dimensiones mm

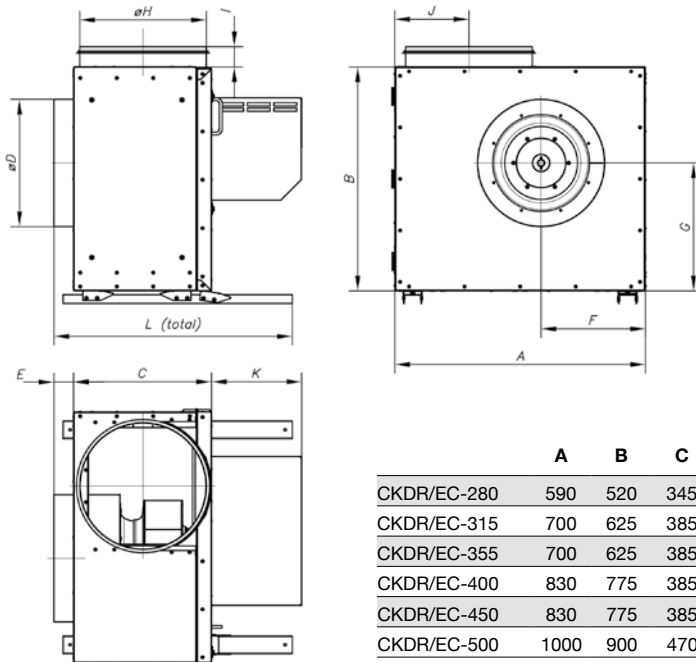

	A	B	C	ØD	E	F	G	ØH	I	J	K	L
CKDR/EC-280	590	520	345	315	52	245	290	315	48	192,5	210	612
CKDR/EC-315	700	625	385	355	55	290	356	355	56	207	210	665
CKDR/EC-355	700	625	385	355	55	290	356	355	56	207	188	665
CKDR/EC-400	830	775	385	355	55	354	418	355	56	212	209	660
CKDR/EC-450	830	775	385	355	55	354	418	355	56	212	229	660
CKDR/EC-500	1000	900	470	400	75	420	505	400	75	244	229	865

Accesorios



Curvas características

Q= Caudal en m³/h, m³/s y cfm

Pe= Presión estática en mmH₂O, Pa e inwg

CKDR-280-2M-1 IE5

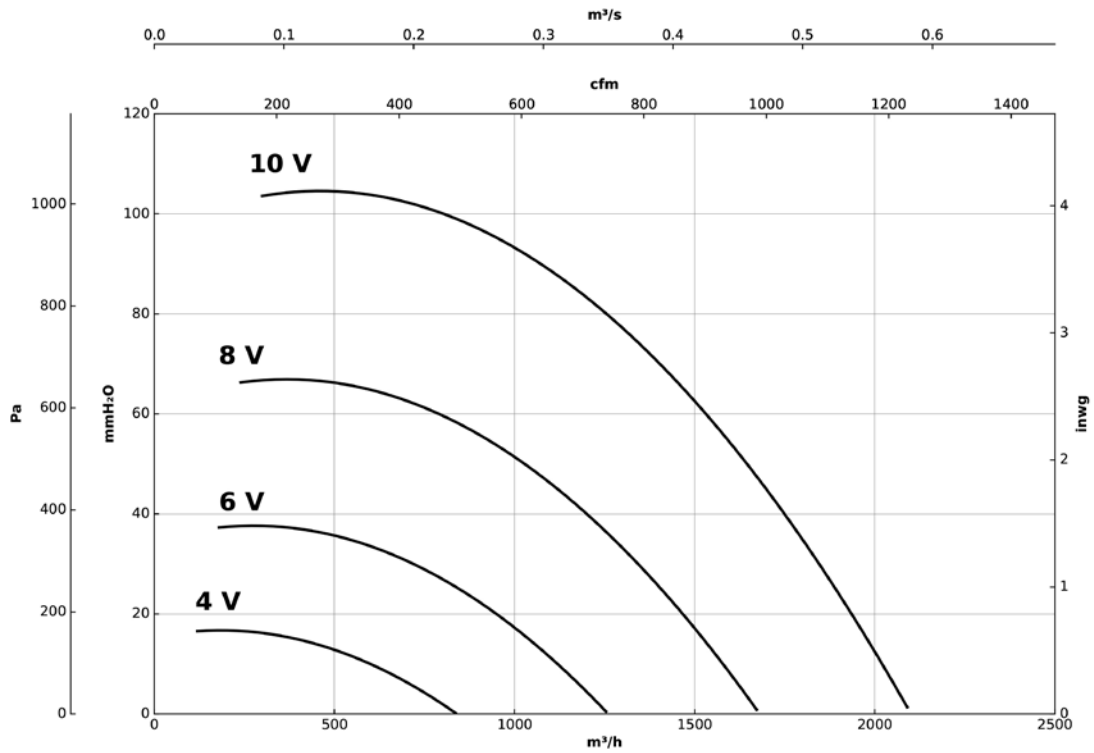

CKDR-315-2M-1,5 IE5

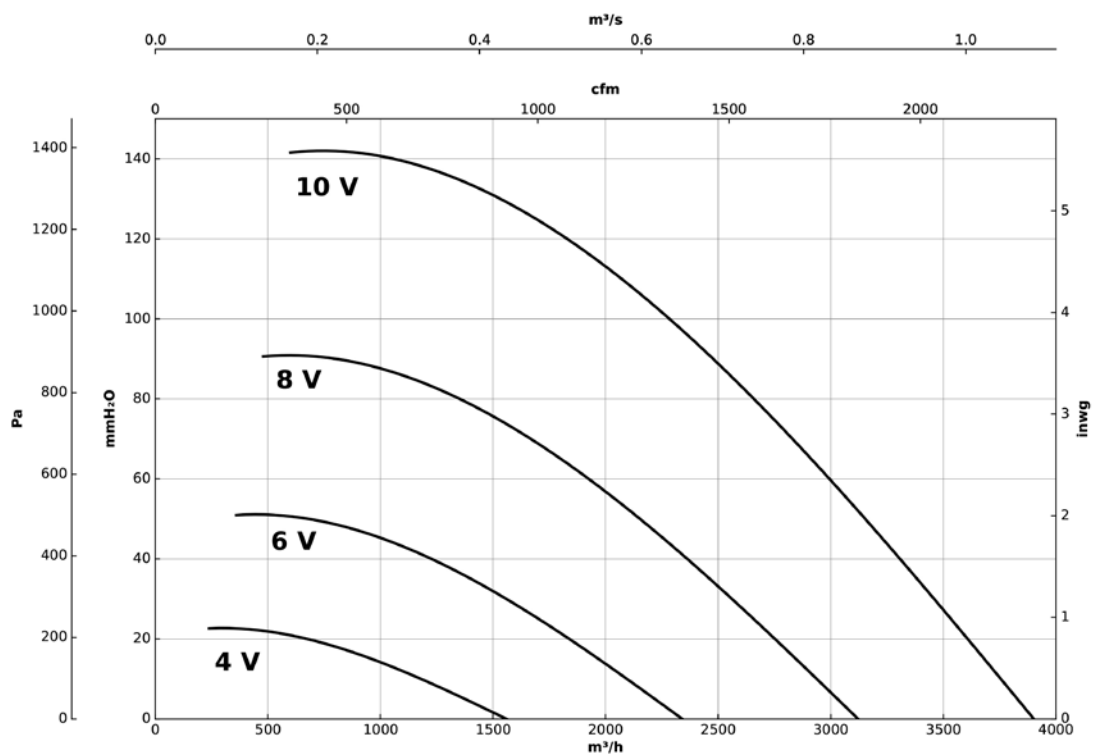

Curvas características

Q= Caudal en m³/h, m³/s y cfm

Pe= Presión estática en mmH₂O, Pa e inwg

CKDR-355-4M-0.5 IE5

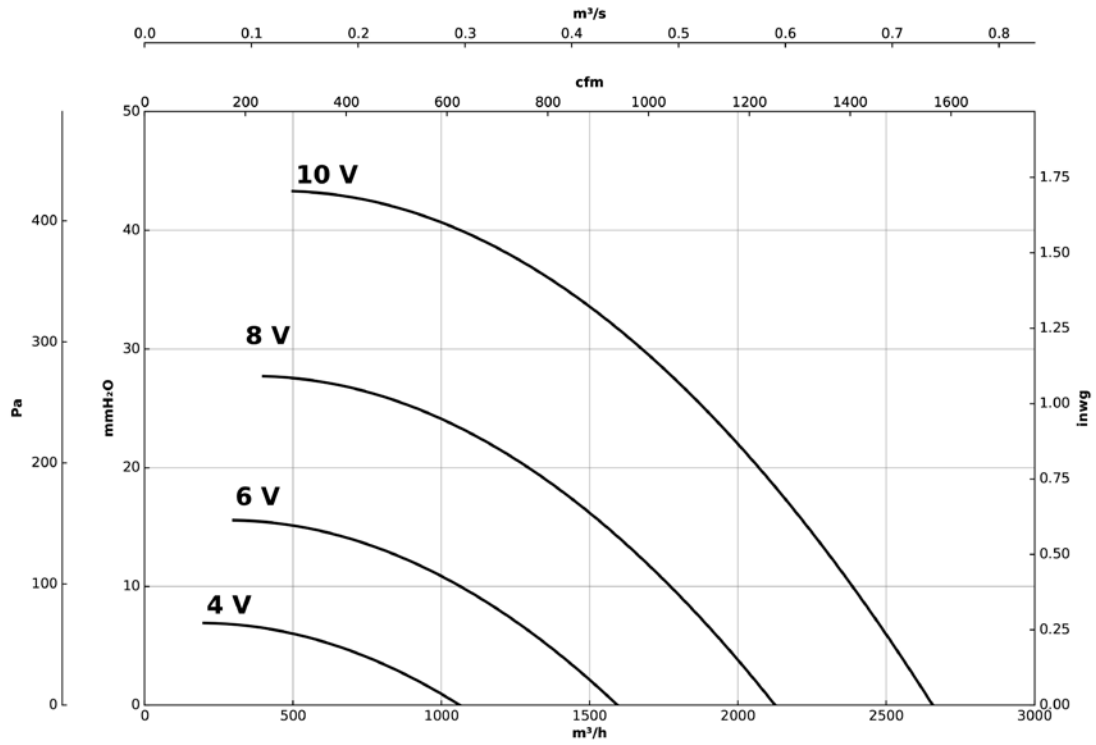

CKDR-400-4M-0.75 IE5

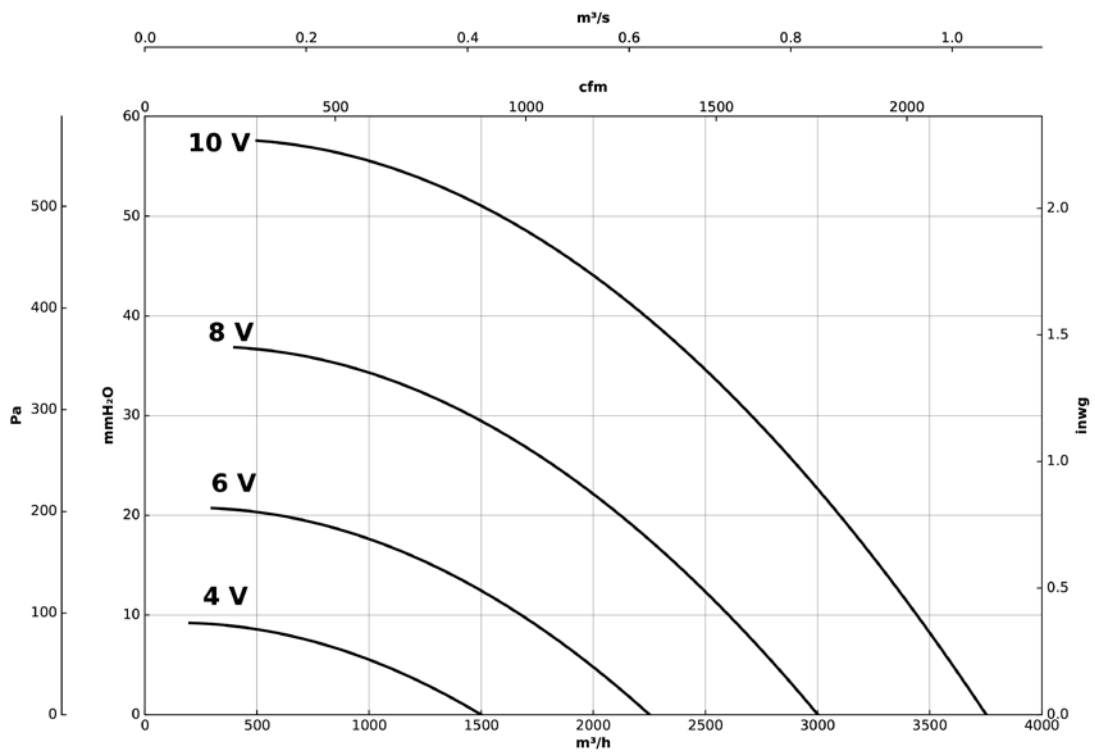

Curvas características

Q= Caudal en m³/h, m³/s y cfm

Pe= Presión estática en mmH₂O, Pa e inwg

CKDR-450-4M-1 IE5

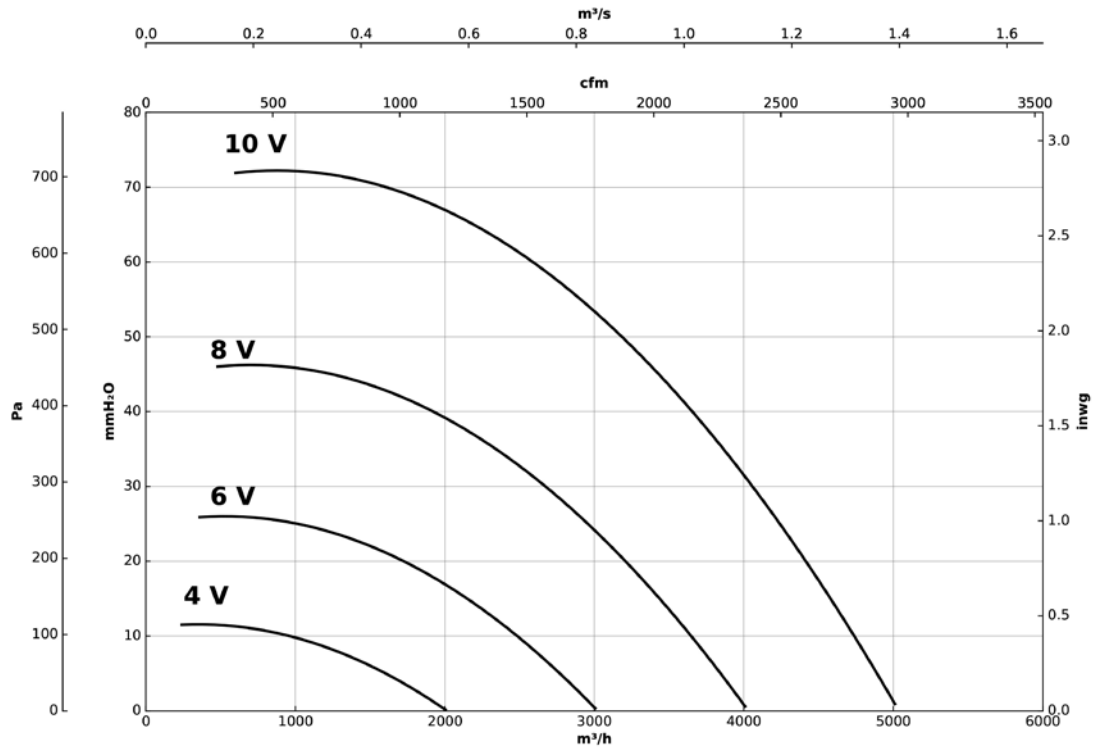

CKDR-500-4M-1.5 IE5

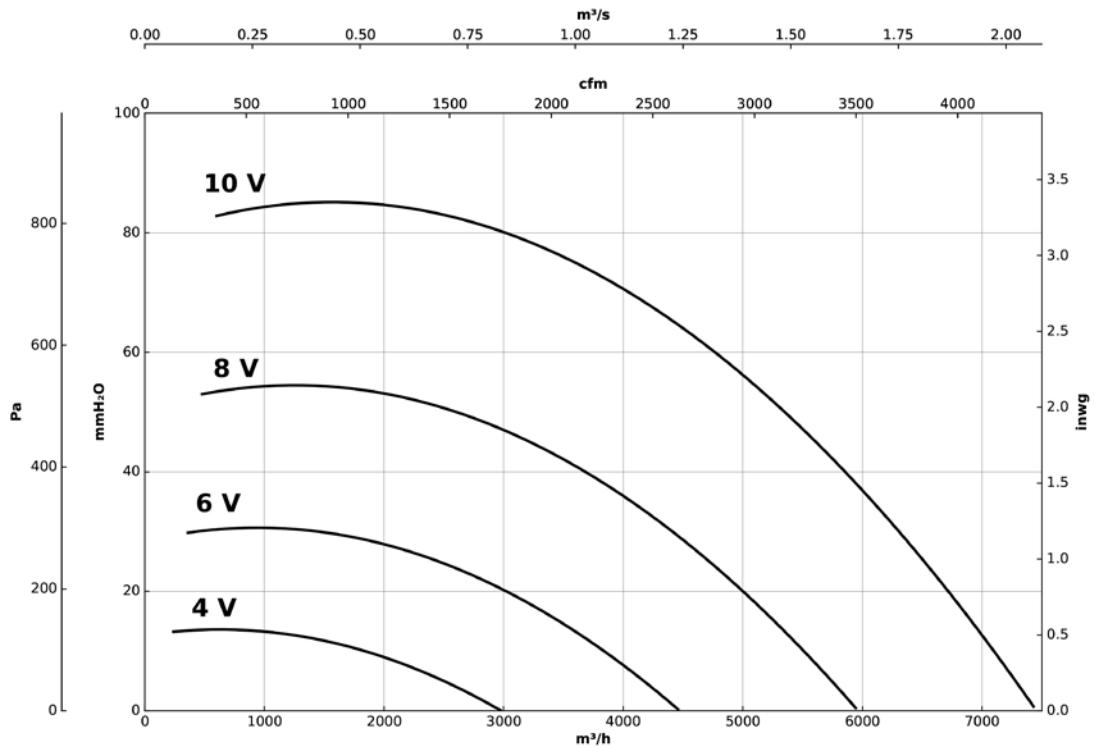

CHT

Extractores centrífugos de tejado 400 °C/2h, con salida de aire horizontal, sombrero en aluminio



Ventilador:

- Base soporte en chapa de acero galvanizado.
- Turbina a reacción en chapa de acero galvanizado.
- Rejilla de protección antipájaros.
- Sombrero deflector antilluvia en aluminio.
- Homologación según norma EN 12101-3, con certificación nº: 0370-CPR-1892.
- Temperatura máxima del aire a transportar: -25 °C +120 °C.

Motor:

- Motores con eficiencia IE3 para potencias iguales o superiores a 0,75 kW, excepto monofásicos, 2 velocidades y 8 polos.

- Motores clase F con rodamientos a bolas y protección IP55. Excepto modelos monofásicos, con protección IP54. De 1 o 2 velocidades según modelo.
- Monofásico 230 V 50 Hz y trifásico 230/400 V 50 Hz.
- Temperatura de trabajo: -25 °C +50 °C.

Acabado:

- Anticorrosivo en chapa de acero galvanizado y aluminio.

Bajo demanda:

- Bobinados especiales para diferentes tensiones.
- Certificación ATEX Categoría 3.

Código de pedido

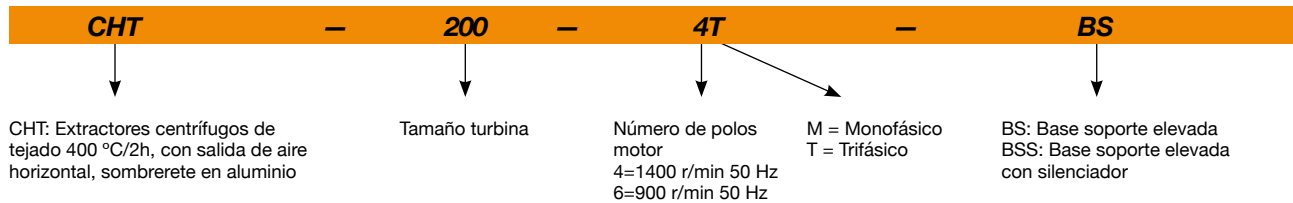

Características técnicas

Modelo	Velocidad (r/min)	Intensidad máxima admisible (A)		Potencia instalada (kW)	Caudal máximo (m³/h)	Nivel presión sonora ¹ dB (A)		Peso aprox. (Kg)
		230V	400V			Aspiración	Descarga	
CHT-200-4T	1350	1,66	0,96	0,25	1450	36	43	25
CHT-200-4M	1380	1,70		0,25	1450	36	43	25
CHT-225-4T	1350	1,66	0,96	0,25	2100	40	46	25
CHT-225-4M	1380	2,60		0,25	2100	40	46	25
CHT-250-4T	1350	1,66	0,96	0,25	3100	44	49	34
CHT-250-4M	1380	2,60		0,25	3100	44	49	34
CHT-315-4T	1380	2,92	1,69	0,55	4950	47	53	39
CHT-315-4M	1380	3,30		0,55	4950	47	53	39
CHT-400-4T IE3	1420	2,82	1,62	0,75	7000	54	60	58
CHT-400-4M	1380	4,40		0,75	7000	54	60	57
CHT-400-6T	900	2,24	1,30	0,37	4500	43	49	56
CHT-450-4T IE3	1440	5,41	3,11	1,50	10200	58	63	74
CHT-450-6T	900	2,24	1,30	0,37	6720	46	53	59
CHT-500-6T IE3	945	4,68	2,69	1,10	12000	50	55	109
CHT-560-6T IE3	950	9,08	5,22	2,20	17300	53	59	130
CHT-630-6T IE3	960	15,60	8,99	4,00	24700	57	61	166

¹ Nivel de presión sonora en dB(A) a 6 m de distancia a caudal máximo.



Erp. (Energy Related Products)

Información de la Directiva 2009/125/EC descargable desde la web de SODECA o programa de selección QuickFan.

Características acústicas

Espectro de potencia sonora Lw(A) en dB(A) por banda de frecuencia en Hz

Valores tomados a la aspiración con caudal máximo (Qmax)

	63	125	250	500	1000	2000	4000	8000
CHT-200-4	37	43	54	57	58	54	52	46
CHT-225-4	44	53	58	58	62	61	54	48
CHT-250-4	48	57	62	62	66	65	58	52
CHT-315-4	52	58	64	64	67	70	61	55
CHT-400-4	59	65	71	71	74	77	68	62
CHT-400-6	48	54	60	60	63	66	57	51
CHT-450-4	64	71	76	76	80	79	72	67
CHT-450-6	52	59	64	64	68	67	60	55
CHT-500-6	56	62	67	68	72	71	64	57
CHT-560-6	59	65	70	71	75	74	67	60
CHT-630-6	63	69	74	75	79	78	71	64

Valores tomados a la descarga con caudal máximo (Qmax)

	63	125	250	500	1000	2000	4000	8000
CHT-200-4	41	46	60	62	63	63	58	53
CHT-225-4	43	52	62	66	69	66	59	53
CHT-250-4	46	55	65	69	72	69	62	56
CHT-315-4	51	63	71	73	74	74	66	58
CHT-400-4	58	70	78	80	81	81	73	65
CHT-400-6	47	59	67	69	70	70	62	54
CHT-450-4	62	74	82	84	85	82	75	67
CHT-450-6	52	64	72	74	75	72	65	57
CHT-500-6	52	66	74	78	77	74	68	62
CHT-560-6	56	70	78	82	81	78	72	66
CHT-630-6	59	73	81	85	74	81	75	69

Dimensiones mm

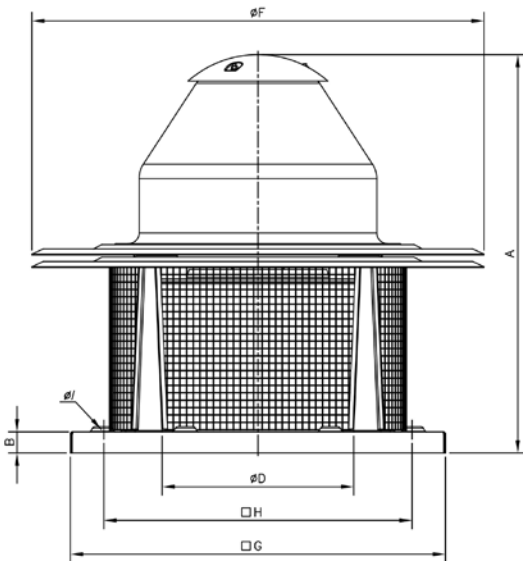

	A	B	øD*	øF	G	H	øI
CHT-200	530	20	250	570	450	360	12
CHT-225	548	20	250	570	450	360	12
CHT-250	620	30	355	726	560	450	12
CHT-315	670	30	355	726	560	450	12
CHT-400	755	40	500	856	710	590	12
CHT-450	770	40	500	856	710	590	12
CHT-500	846	40	630	1072	900	750	14
CHT-560	1035	40	710	1300	1100	900	14
CHT-630	1096	40	710	1300	1100	900	14

* Diámetro nominal tubería recomendada.

Curvas características

Q= Caudal en m³/h, m³/s y cfm

Pe= Presión estática en mmH₂O, Pa e inwg

4M/4T=1500 r/min

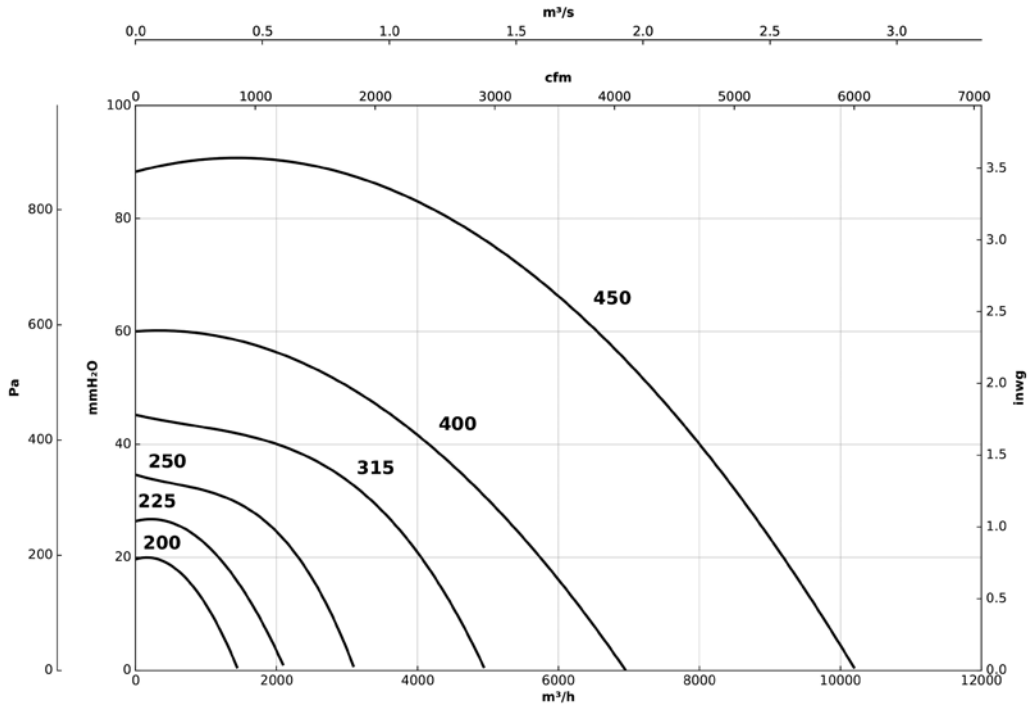

6T=1000 r/min

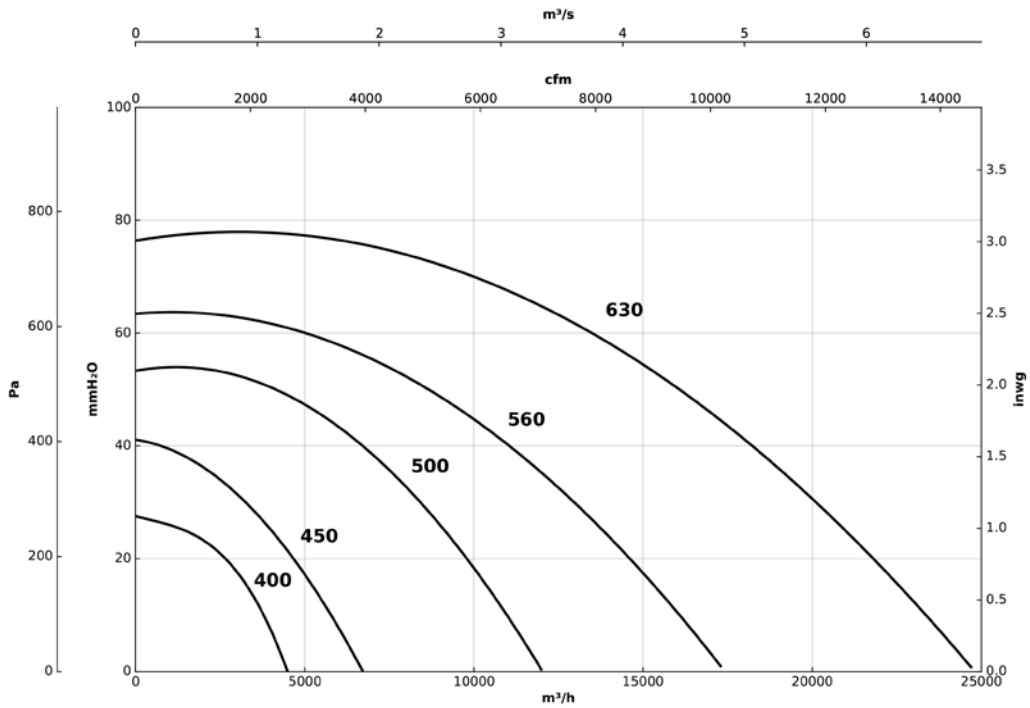

Variación de la presión sonora según distancia

El nivel sonoro puede variar dependiendo de la estructura de la cubierta o tejado.

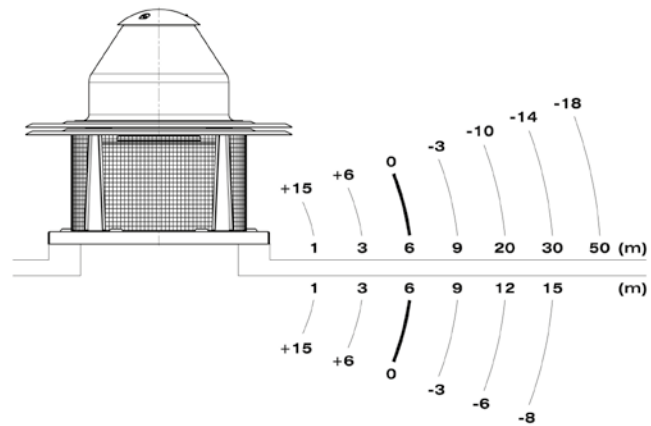

Ejemplo de aplicación

Extractores idóneos para aplicación en cocinas industriales

Para la correcta aplicación de la norma:

- C.T.E. Código Técnico de la Edificación. Documento Básico SI de seguridad en caso de incendio. Documento Básico HS de salubridad.

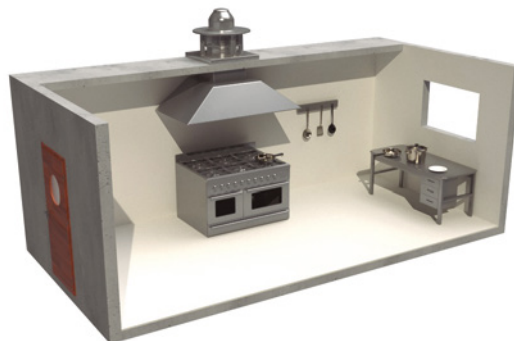

Accesorios



INT



C2V



RM



VSD3/A-RFT
- VSD1/A-RFM



B



BAC

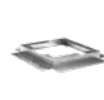

MS



PA



BS



BSS



PT



S



SI-PIR



SI-TEMP+HUMEDAD



SI-PRESIÓN



SI-FUENTE DE ALIMENTACIÓN



SI-VENT



SI-PRESOSTATO

CHT/EC



Extractores centrífugos de tejado con salida de aire horizontal, con motor EC Technology IE5



Ventilador:

- Base soporte en chapa de acero galvanizado.
- Turbina a reacción en chapa de acero galvanizado.
- Rejilla de protección antipájaros.
- Sombbrero deflector antilluvia en aluminio.
- Dirección aire motor-hélice.

Motor:

- Motores EC Technology de alta eficiencia con electrónica integrada, regulables mediante 0-10 V o 4-20 mA.
- Motores con eficiencia IE5, clase F y protección IP55.
- Monofásico 230 V 50/60 Hz.
- Temperatura de trabajo: -20 °C +60 °C.

- DAY/NIGHT: Ajuste de doble consigna de presión según momento del día.
- Sensor externo: Compatible con sensor de temperatura, humedad, calidad de aire o CO.
- Equipo preconfigurado en modo presión constante con set point de 100 Pa.

Acabado:

- Anticorrosivo en chapa de acero galvanizado y aluminio.



MOTOR EC TECHNOLOGY con electrónica integrada



EC CONTROL Suministro como accesorio opcional

EC CONTROL: Se suministra como accesorio opcional. Cuadro de control para sistemas de ventilación con motores EC Technology que lleven la electrónica integrada en el propio motor. Con las siguientes características:

- CPC: Control de presión constante.
- CFC: Control de caudal constante.

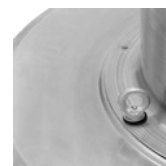

Soportes que facilitan la colocación al tejado



Código de pedido

CHT/EC – **315** – **4M** – **0.75** – **IE5**

CHT/EC: Extractores centrífugos de tejado con salida de aire horizontal, con motor EC Technology IE5

Tamaño turbina

Número de polos motor
4=1400 r/min 50 Hz
6=900 r/min 50 Hz

M = Monofásico

Potencia motor (CV)

Motor IE5

Características técnicas

Modelo	Velocidad (r/min)	Intensidad máxima admisible (A)	Potencia eléctrica máx.	Caudal máximo (m³/h)	Nivel de presión sonora dB (A)		Peso aprox. (Kg)
		230V	(kW)		Aspiración	Descarga	
CHT/EC-315-4M-0.75 IE5	1380	4,8	0,55	4950	48	54	39
CHT/EC-400-6M-0.55 IE5	900	3,4	0,37	4500	44	50	56
CHT/EC-450-6M-0.55 IE5	900	3,4	0,37	6900	47	54	59



Erp. (Energy Related Products)

Información de la Directiva 2009/125/EC descargable desde la web de SODECA o programa de selección QuickFan

Características acústicas

Los valores indicados, se determinan mediante medidas de nivel de presión y potencia sonora en dB(A) obtenidas en campo libre a una distancia equivalente a dos veces la envergadura del ventilador más el diámetro de la turbina, con un mínimo de 1,5 m.

Espectro de potencia sonora Lw(A) en dB(A) por banda de frecuencia en Hz

Valores tomados a la aspiración con caudal máximo (Qmax)

	63	125	250	500	1000	2000	4000	8000
315-4M	50	56	62	62	65	68	59	53
400-6M	46	52	58	58	61	64	55	49
450-6M	50	57	62	62	66	65	58	53

Valores tomados a la descarga con caudal máximo (Qmax)

	63	125	250	500	1000	2000	4000	8000
315-4M	49	61	69	71	72	72	84	58
400-6M	45	57	65	67	68	68	60	52
450-6M	50	62	70	72	73	70	63	55

Dimensiones mm

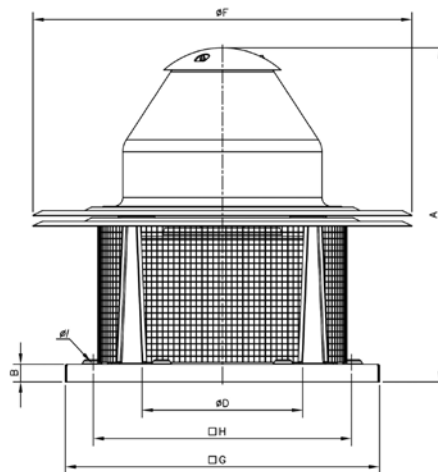

	A	B	øD*	øF	G	H	øl
CHT/EC-315-4M	670	30	355	726	560	450	12
CHT/EC-400-6M	755	40	500	856	710	590	12
CHT/EC-450-6M	770	40	500	856	710	590	12

* Diámetro nominal tubería recomendada

Curvas características

Q= Caudal en m³/h, m³/s y cfm

Pe= Presión estática en mmH₂O, Pa e inwg

CHT/EC-315-4M

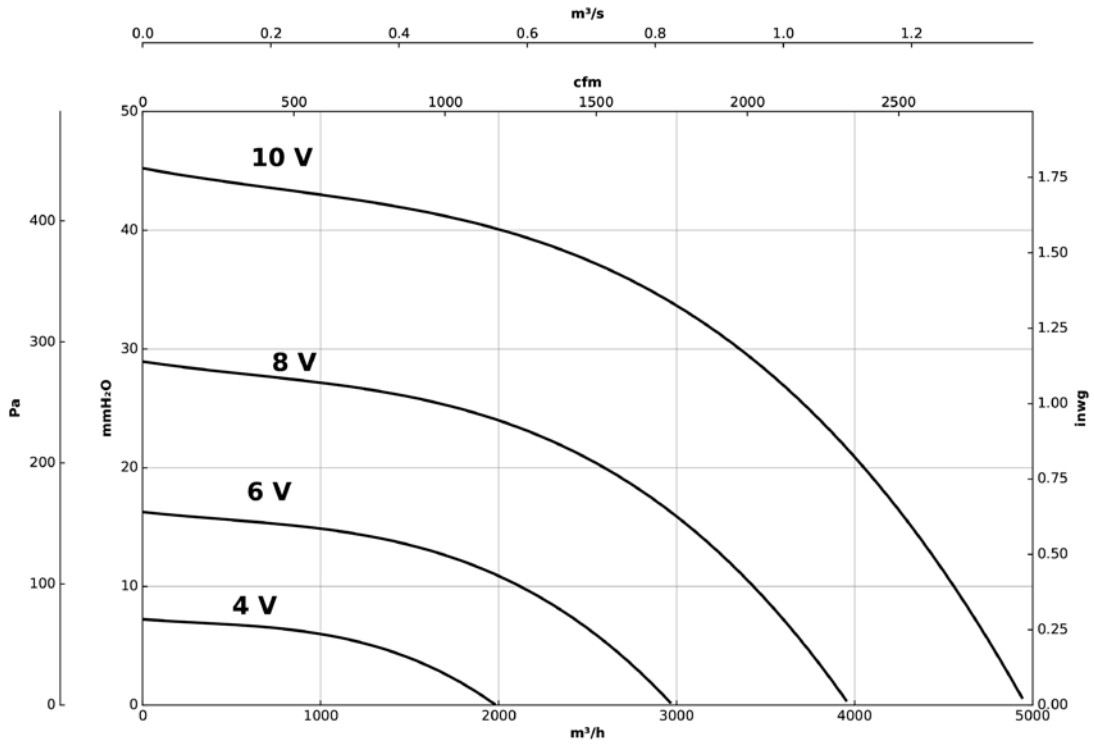

CHT/EC-400-6M

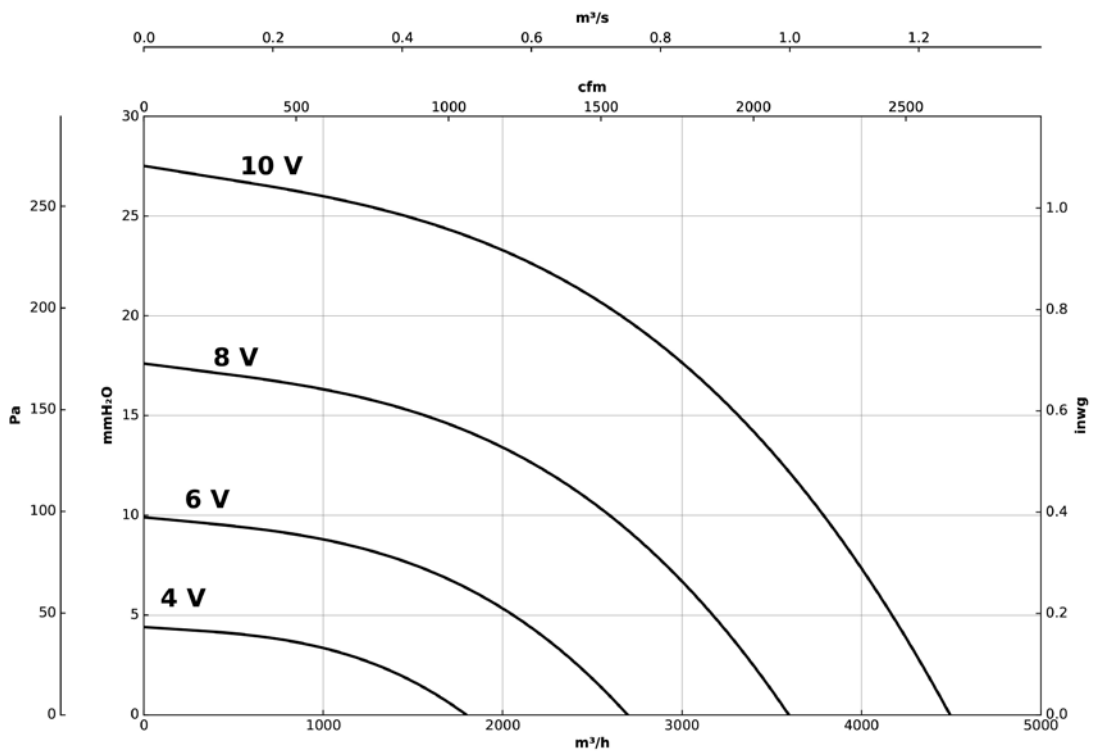

Curvas características

Q= Caudal en m³/h, m³/s y cfm

Pe= Presión estática en mmH₂O, Pa e inwg

CHT/EC-450-6M

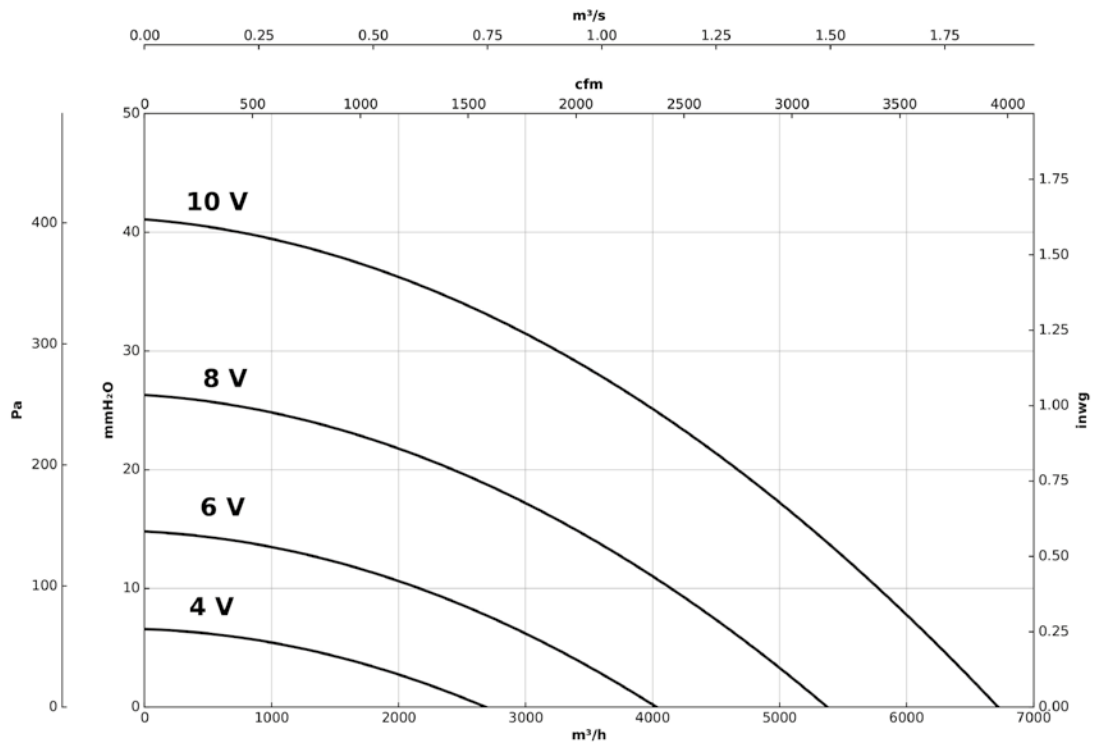

Accesorios

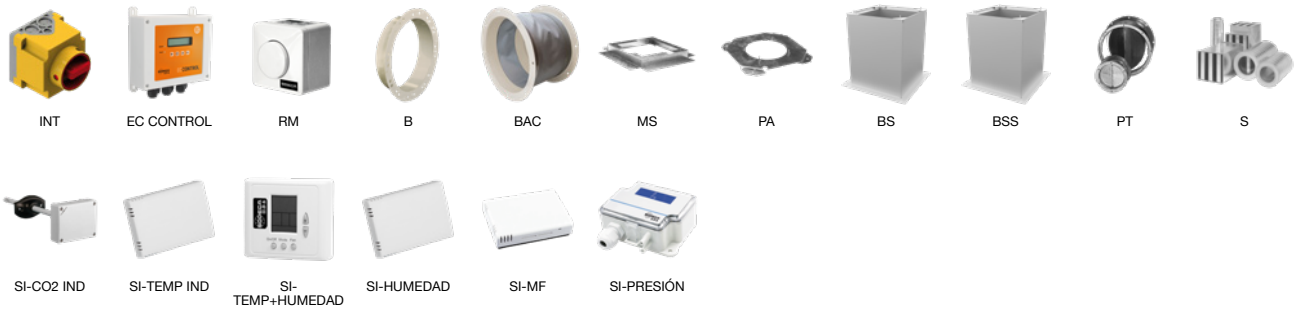

CVT

Extractores centrífugos de tejado 400 °C/2h, con salida de aire vertical, sombrero en aluminio



Ventilador:

- Base soporte en chapa de acero galvanizado.
- Turbina a reacción en chapa de acero galvanizado.
- Rejilla de protección antipájaros.
- Sombrero deflector antilluvia en aluminio.
- Homologación según norma EN 12101-3, con certificación n°: 0370-CPR-1892.
- Temperatura máxima del aire a transportar: -25 °C +120 °C.

- Motores clase F con rodamientos a bolas y protección IP55. Excepto modelos monofásicos, con protección IP54. De 1 o 2 velocidades según modelo.
- Monofásico 230 V 50 Hz y trifásico 230/400 V 50 Hz.
- Temperatura de trabajo: -25 °C +50 °C.

Acabado:

- Anticorrosivo en chapa de acero galvanizado y aluminio.

Motor:

- Motores con eficiencia IE3 para potencias iguales o superiores a 0,75 kW, excepto monofásicos, 2 velocidades y 8 polos.

Bajo demanda:

- Bobinados especiales para diferentes tensiones.
- Certificación ATEX Categoría 3.

Código de pedido

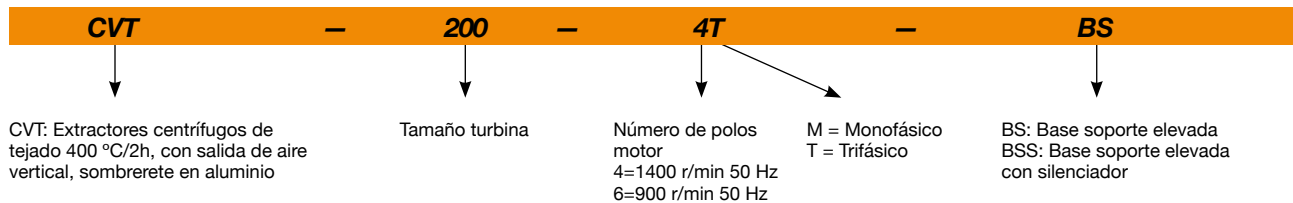

Características técnicas

Modelo	Velocidad (r/min)	Intensidad máxima admisible (A)		Potencia instalada (kW)	Caudal máximo (m³/h)	Nivel presión sonora ¹ dB (A)		Peso aprox. (Kg)
		230V	400V			Aspiración	Descarga	
CVT-200-4T	1350	1,66	0,96	0,25	1450	36	43	25
CVT-200-4M	1380	1,70		0,25	1450	36	43	25
CVT-225-4T	1350	1,66	0,96	0,25	2100	40	46	25
CVT-225-4M	1380	2,60		0,25	2100	40	46	25
CVT-250-4T	1350	1,66	0,96	0,25	3100	44	49	34
CVT-250-4M	1380	2,60		0,25	3100	44	49	34
CVT-315-4T	1380	2,92	1,69	0,55	4950	47	53	39
CVT-315-4M	1380	3,30		0,55	4950	47	53	39
CVT-400-4T IE3	1420	2,82	1,62	0,75	7000	54	60	58
CVT-400-4M	1380	4,40		0,75	7000	54	60	57
CVT-400-6T	900	2,24	1,30	0,37	4500	43	49	56
CVT-450-4T IE3	1440	5,41	3,11	1,50	10200	58	63	74
CVT-450-6T	900	2,24	1,30	0,37	6720	46	53	59
CVT-500-6T IE3	945	4,68	2,69	1,10	12000	50	55	109
CVT-560-6T IE3	950	9,08	5,22	2,20	17300	53	59	130
CVT-630-6T IE3	960	15,60	8,99	4,00	24700	57	61	166

¹ Nivel de presión sonora en dB(A) a 6 m de distancia a caudal máximo.



Erp. (Energy Related Products)

Información de la Directiva 2009/125/EC descargable desde la web de SODECA o programa de selección QuickFan.

Características acústicas

Espectro de potencia sonora Lw(A) en dB(A) por banda de frecuencia en Hz

Valores tomados a la aspiración con caudal máximo (Qmax)

	63	125	250	500	1000	2000	4000	8000
CVT-200-4	37	43	54	57	58	54	52	46
CVT-225-4	44	53	58	58	62	61	54	48
CVT-250-4	48	57	62	62	66	65	58	52
CVT-315-4	52	58	64	64	67	70	61	55
CVT-400-4	59	65	71	71	74	77	68	62
CVT-400-6	48	54	60	60	63	66	57	51
CVT-450-4	64	71	76	76	80	79	72	67
CVT-450-6	52	59	64	64	68	67	60	55
CVT-500-6	56	62	67	68	72	71	64	57
CVT-560-6	59	65	70	71	75	74	67	60
CVT-630-6	63	69	74	75	79	78	71	64

Valores tomados a la descarga con caudal máximo (Qmax)

	63	125	250	500	1000	2000	4000	8000
CVT-200-4	41	46	60	62	63	63	58	53
CVT-225-4	43	52	62	66	69	66	59	53
CVT-250-4	46	55	65	69	72	69	62	56
CVT-315-4	51	63	71	73	74	74	66	58
CVT-400-4	58	70	78	80	81	81	73	65
CVT-400-6	47	59	67	69	70	70	62	54
CVT-450-4	62	74	82	84	85	82	75	67
CVT-450-6	52	64	72	74	75	72	65	57
CVT-500-6	52	66	74	78	77	74	68	62
CVT-560-6	56	70	78	82	81	78	72	66
CVT-630-6	59	73	81	85	74	81	75	69

Dimensiones mm

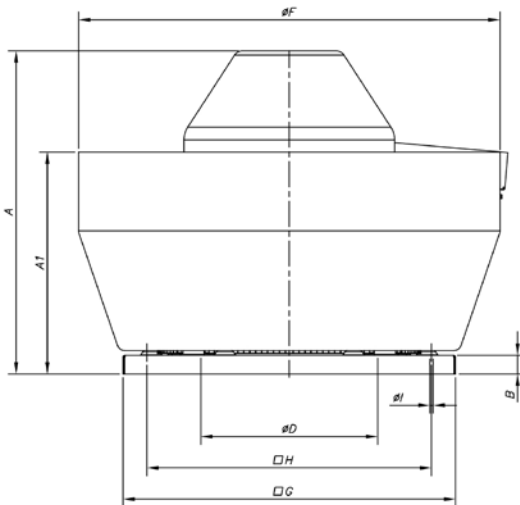

	A	A1	B	øD*	øF	G	H	øI
CVT-200	472	296	20	250	530	450	360	12
CVT-225	490	296	20	250	530	450	360	12
CVT-250	562	248	30	355	700	560	450	12
CVT-315	612	373	30	355	700	560	450	12
CVT-400	689	473	40	500	900	710	590	12
CVT-450	705	474	40	500	900	710	590	12
CVT-500	772	545	40	630	1100	900	750	14
CVT-560	957	678	40	710	1295	1100	900	14
CVT-630	1017	676	40	710	1295	1100	900	14

* Diámetro nominal tubería recomendada.

Curvas características

Q= Caudal en m³/h, m³/s y cfm

Pe= Presión estática en mmH₂O, Pa e inwg

4M/4T=1500 r/min

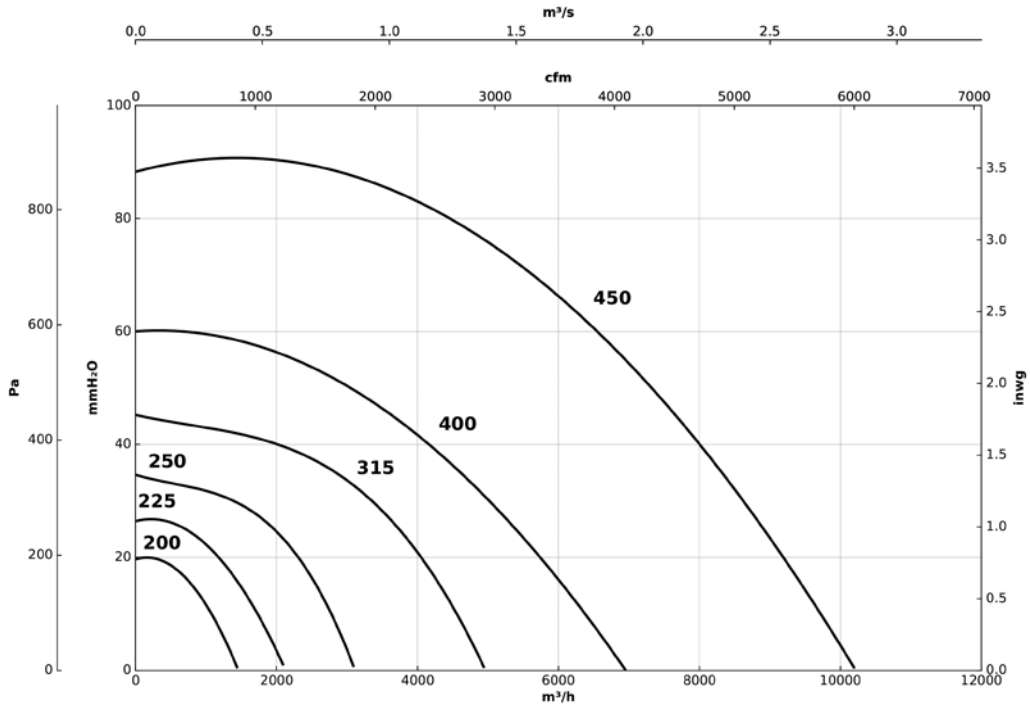

6T=1000 r/min

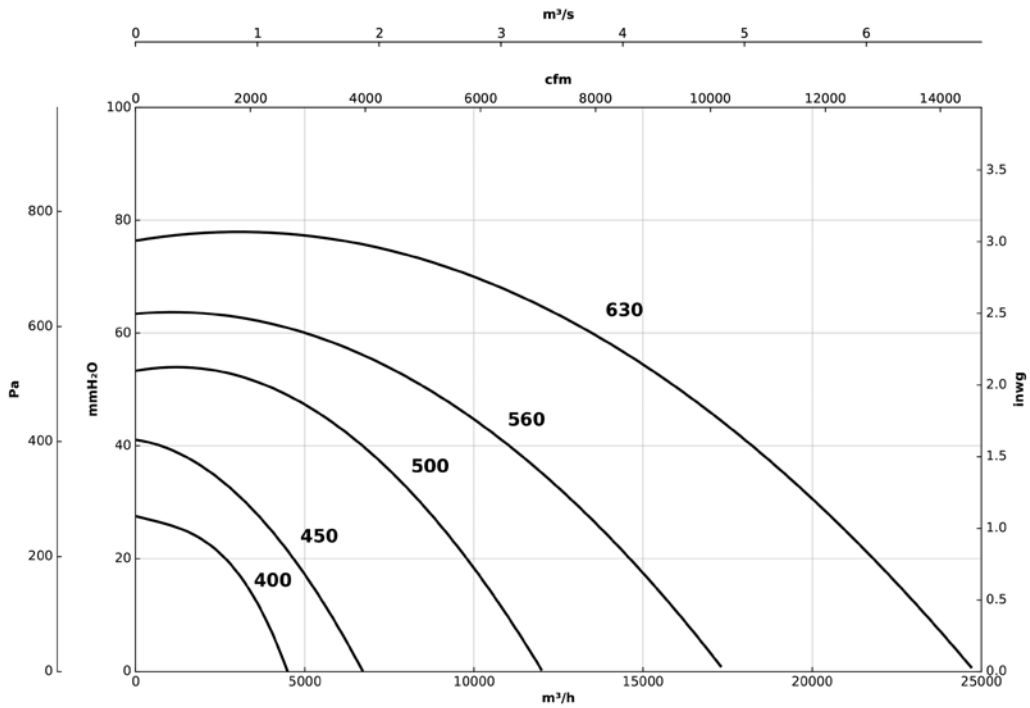

Variación de la presión sonora según distancia

El nivel sonoro puede variar dependiendo de la estructura de la cubierta o tejado.

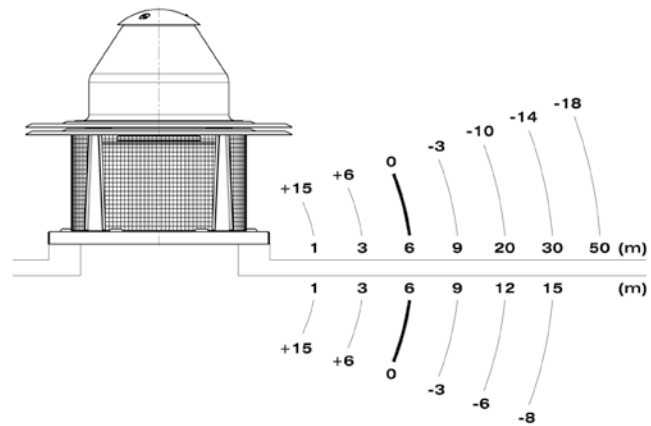

Ejemplo de aplicación

Extractores idóneos para aplicación en cocinas industriales

Para la correcta aplicación de la norma:

- C.T.E. Código Técnico de la Edificación. Documento Básico SI de seguridad en caso de incendio. Documento Básico HS de salubridad.

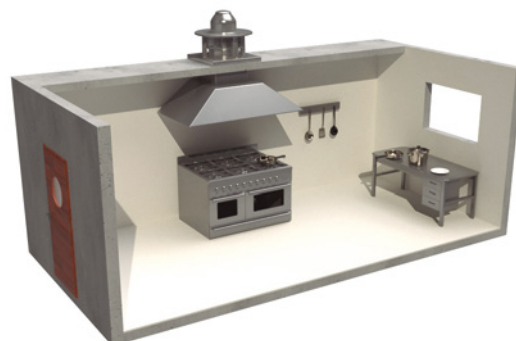

Accesorios



INT



C2V



RM



VSD3/A-RFT
- VSD1/A-RFM



B



BAC

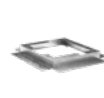

MS



PA



BS



BSS



PT



S



SI-PIR



SI-TEMP+HUMEDAD



SI-PRESIÓN



SI-FUENTE DE ALIMENTACIÓN



SI-VENT



SI-PRESOSTATO

CVT/EC

Extractores centrífugos de tejado con salida de aire vertical, con motor EC Technology IE5



MOTOR EC TECHNOLOGY con electrónica integrada



EC CONTROL Suministro como accesorio opcional

Ventilador:

- Base soporte en chapa de acero galvanizado.
- Turbina a reacción en chapa de acero galvanizado.
- Rejilla de protección antipájaros.
- Sombbrero deflector antilluvia en aluminio.
- Dirección aire motor-hélice.

Motor:

- Motores EC Technology de alta eficiencia con electrónica integrada, regulables mediante 0-10 V o 4-20 mA.
- Motores con eficiencia IE5, clase F y protección IP55.
- Monofásico 230 V 50/60 Hz.
- Temperatura de trabajo: -20 °C +60 °C.

EC CONTROL: Se suministra como accesorio opcional. Cuadro de control para sistemas de ventilación con motores EC Technology que lleven la electrónica integrada en el propio motor. Con las siguientes características:

- CPC: Control de presión constante.
- CFC: Control de caudal constante.

- DAY/NIGHT: Ajuste de doble consigna de presión según momento del día.
- Sensor externo: Compatible con sensor de temperatura, humedad, calidad de aire o CO.
- Equipo preconfigurado en modo presión constante con set point de 100 Pa.

Acabado:

- Anticorrosivo en chapa de acero galvanizado y aluminio.

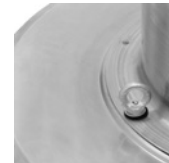

Soportes que facilitan la colocación al tejado



Código de pedido

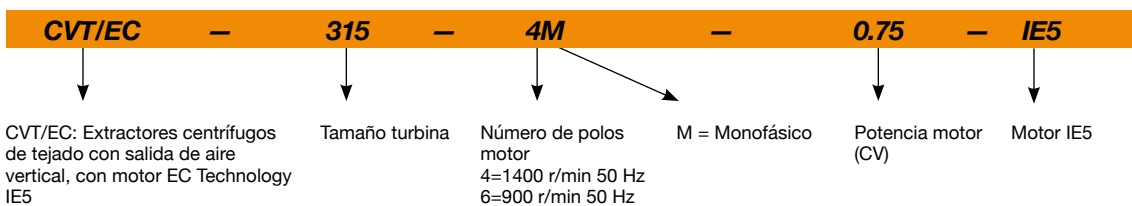

Características técnicas

Modelo	Velocidad (r/min)	Intensidad máxima admisible (A)	Potencia eléctrica máx.	Caudal máximo	Nivel de presión sonora dB (A)		Peso aprox. (Kg)
		230V	(kW)	(m³/h)	Aspiración	Descarga	
CVT/EC-315-4M-0.75 IE5	1380	4,8	0,55	4950	48	54	39
CVT/EC-400-6M-0.55 IE5	900	3,4	0,37	4500	44	50	56
CVT/EC-450-6M-0.55 IE5	900	3,4	0,37	6900	47	54	59



Erp. (Energy Related Products)

Información de la Directiva 2009/125/EC descargable desde la web de SODECA o programa de selección QuickFan

Características acústicas

Los valores indicados, se determinan mediante medidas de nivel de presión y potencia sonora en dB(A) obtenidas en campo libre a una distancia equivalente a dos veces la envergadura del ventilador más el diámetro de la turbina, con un mínimo de 1,5 m.

Espectro de potencia sonora Lw(A) en dB(A) por banda de frecuencia en Hz

Valores tomados a la aspiración con caudal máximo (Qmax)

	63	125	250	500	1000	2000	4000	8000
315-4M	50	56	62	62	65	68	59	53
400-6M	46	52	58	58	61	64	55	49
450-6M	50	57	62	62	66	65	58	53

Valores tomados a la descarga con caudal máximo (Qmax)

	63	125	250	500	1000	2000	4000	8000
315-4M	49	61	69	71	72	72	84	58
400-6M	45	57	65	67	68	68	60	52
450-6M	50	62	70	72	73	70	63	55

Dimensiones mm

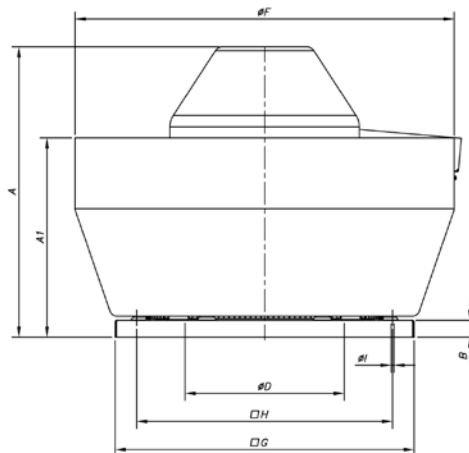

	A	A1	B	øD*	øF	G	H	øl
CVT/EC-315-4M	612	373	30	355	700	560	450	12
CVT/EC-400-6M	689	473	40	500	900	710	590	12
CVT/EC-450-6M	705	474	40	500	900	710	590	12

* Diámetro nominal tubería recomendada

Curvas características

Q= Caudal en m³/h, m³/s y cfm

Pe= Presión estática en mmH₂O, Pa e inwg

CVT/EC-315-4M

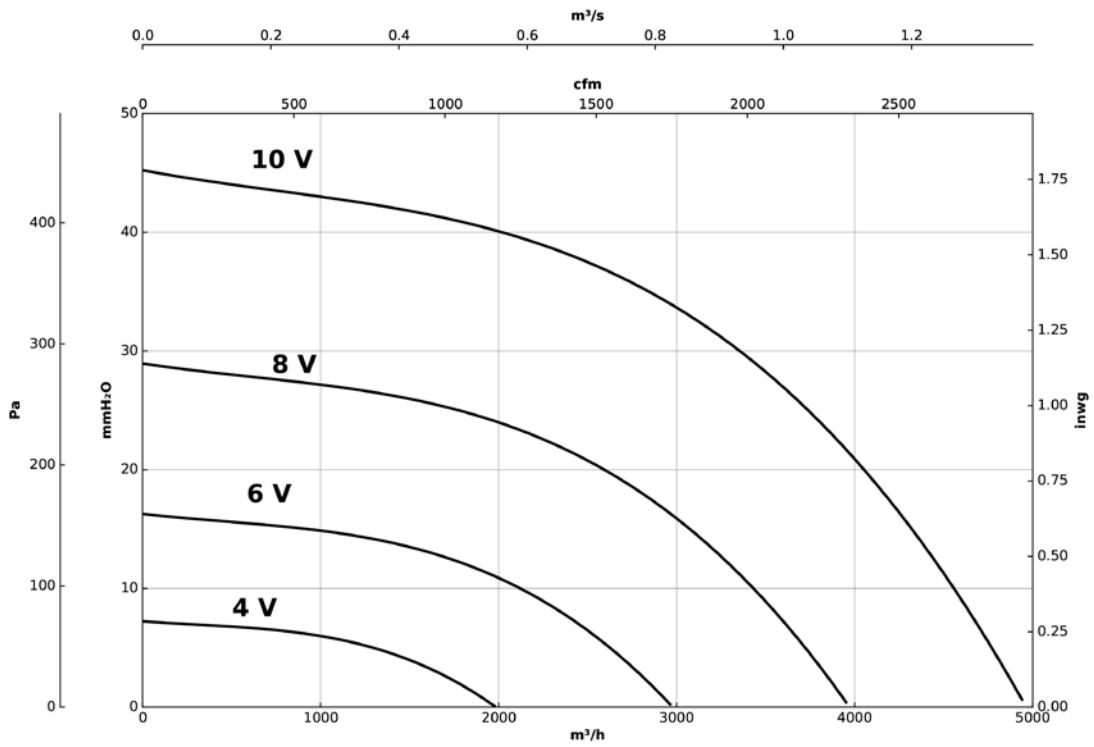

CVT/EC-400-6M

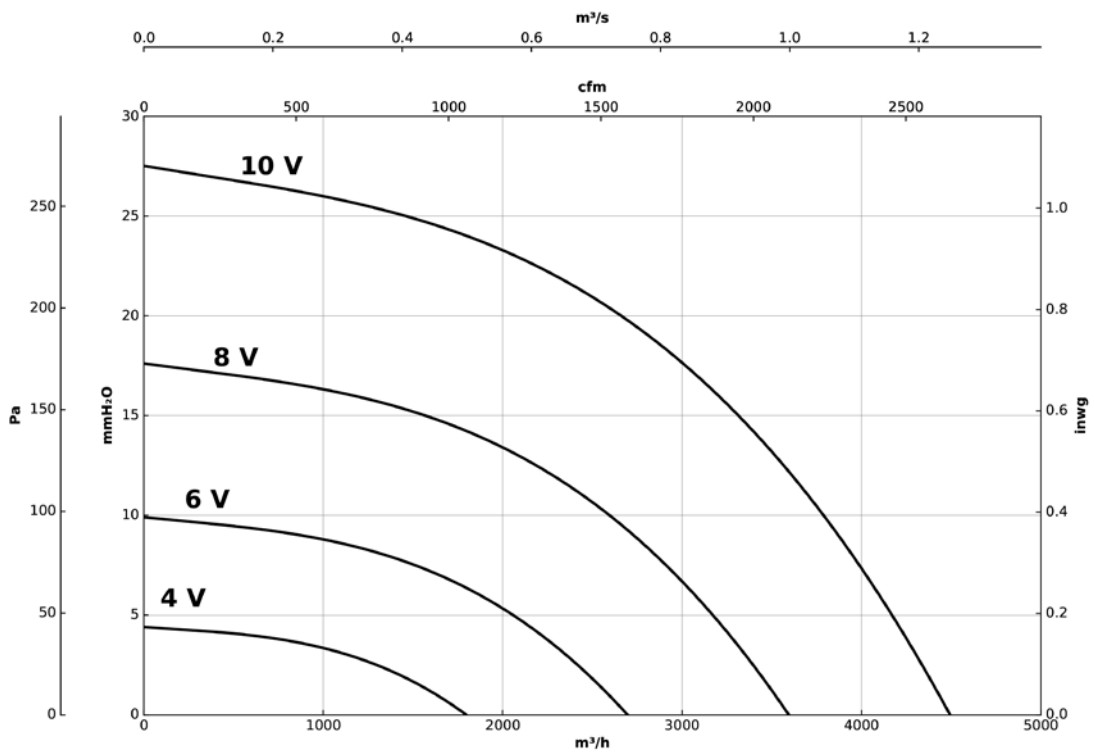

Curvas características

Q= Caudal en m³/h, m³/s y cfm

Pe= Presión estática en mmH₂O, Pa e inwg

CVT/EC-450-6M

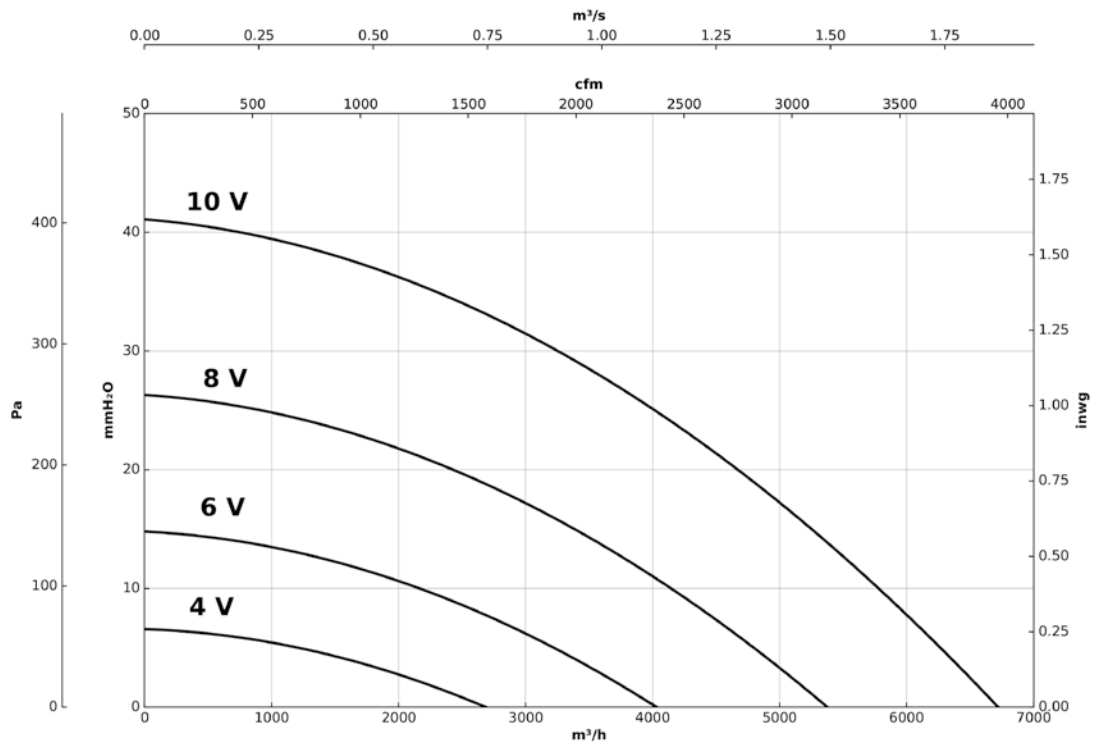

Accesorios

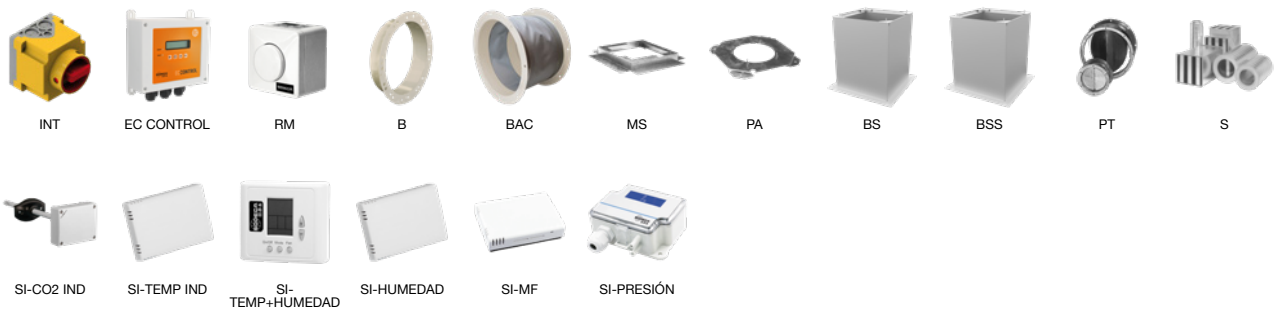

KIT BOXPDS



Equipos de presurización para vías de evacuación, diseñados según la norma europea EN 12101-6



Equipos de presurización de vías de evacuación en caso de incendio diseñados según la norma europea EN 12101-6. El KIT BOXPDS regula de forma automática el flujo de aire y es capaz de mantener los 50 Pa de sobrepresión aún con presencia de fugas en la instalación. El sistema es capaz de mantener la sobrepresión (Pressure criteria) y alcanzar el 90% del caudal requerido dentro de los 3 segundos siguientes a la apertura o cierre de una puerta (Airflow criteria).

Incluyendo certificación de ensayos de comportamiento dinámico, compatibilidad electromagnética, resistencia ambiental y grado de protección IP.

Modelo de utilidad: ES 1 226 660 U.

KIT BOXPDS

- Consta del cuadro de control BOXPDS, cuadro de mandos externo, una unidad de ventilación CJHCH y un DAMPER BOX con detector óptico de humos incorporado.

BOXPDS

- Variador de frecuencia Inverter.
- Sonda de presión diferencial de gran precisión.
- Cuadro eléctrico con protecciones magnetotérmicas e indicación de fallo en la alimentación general.
- Control electrónico para gestión de alarmas, mantenimiento, puerto ModBUS RTU para conexión a sistemas BMS (Building Management Systems) y control de DAMPER BOX.
- Fuente de alimentación certificada con baterías para asegurar la alimentación de los equipos de control en caso de fallo en la red eléctrica.
- Incluye programación horaria para activar ventilación diaria.

Cuadro de mandos:

- Cuadro de mandos externo con pantalla táctil para la visualización de la presión a tiempo real, configuración y calibración del sistema, pilotos de estado y activación manual del sistema.
- Selector Auto-Manual-Off.
- Selector Reset alarma incendio.
- Selector Test.

Bajo demanda:

- Sistema conmutación automático para ventilador de reserva (ver serie KIT BOXPDS II).

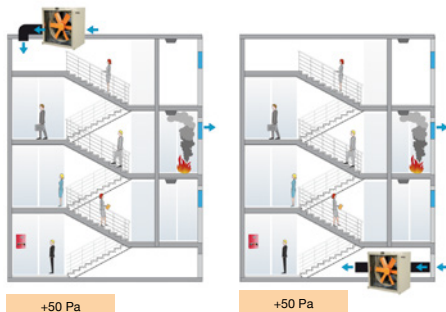

- Fácil instalación.
- Solución compacta y autónoma.
- Fácil puesta en marcha.
- Instalación segura y funcional.

Código de pedido

KIT BOXPDS — **800** — **4T** — **5.5**

KIT BOXPDS: Equipos de presurización para vías de evacuación, diseñados según la norma europea EN 12101-6
KIT BOXPDS II: Equipos de presurización para vías de evacuación con ventilador de reserva, diseñados según la norma europea EN 12101-6

Diámetro hélice en cm

Número de polos motor
4=1400 r/min 50 Hz

T = Trifásico

Potencia motor (CV)

Características técnicas

Modelo	Velocidad	Alimentación	Intensidad máxima admisible (A)	Potencia instalada	Caudal máximo	Nivel presión sonora	Peso aprox.
	(r/min)	(V) (Hz)	400V	(kW)	(m³/h)	dB (A)	(Kg)
KIT BOXPDS-710-4T-1.5 IE3	1400	380-480 V 50/60 Hz	4,75	1,1	19770	75	188
KIT BOXPDS-710-4T-2 IE3	1430	380-480 V 50/60 Hz	6,25	1,5	21090	75	191
KIT BOXPDS-710-4T-3 IE3	1445	380-480 V 50/60 Hz	8,20	2,2	23970	78	200
KIT BOXPDS-800-4T-3 IE3	1445	380-480 V 50/60 Hz	8,20	2,2	27940	79	208
KIT BOXPDS-800-4T-4 IE3	1445	380-480 V 50/60 Hz	10,05	3,0	32720	80	210
KIT BOXPDS-800-4T-5.5 IE3	1440	380-480 V 50/60 Hz	12,65	4,0	37440	81	215
KIT BOXPDS-900-4T-7.5 IE3	1440	380-480 V 50/60 Hz	15,20	5,5	47550	88	309
KIT BOXPDS-900-4T-10 IE3	1455	380-480 V 50/60 Hz	20,30	7,5	53120	89	326
KIT BOXPDS-1000-4T-10 IE3	1455	380-480 V 50/60 Hz	20,30	7,5	58560	90	334
KIT BOXPDS-1000-4T-15 IE3	1460	380-480 V 50/60 Hz	28,30	11,0	68000	91	366
KIT BOXPDS-1000-4T-20 IE3	1460	380-480 V 50/60 Hz	36,60	15,0	71850	92	377

Se pueden suministrar con KIT BOXPDS II para ventilador de reserva (se añade una segunda unidad de impulsión equivalente a la del KIT BOXPDS).

Dimensiones mm

KIT BOXPDS

	A	B	C	D	E	F	G	H	I	J	K	L	O
KIT BOXPDS-710/800	1314	300	1000	976,5	326,5	1000	650	995	600	850	650	850	1000
KIT BOXPDS-900/1000	1540	300	1200	1102	326,5	1200	750	1195	800	1050	750	1050	1200

Dimensiones mm

	BOXPDS			DAMPER BOX			CJHCH		
	C	B	I	E	J	H	O	K	L
BOXPDS-710/800	1000	300	600	326,5	850	995	1000	650	850
BOXPDS-900/1000	1200	300	800	326,5	1050	1195	1200	750	1050

Ejemplo de aplicación

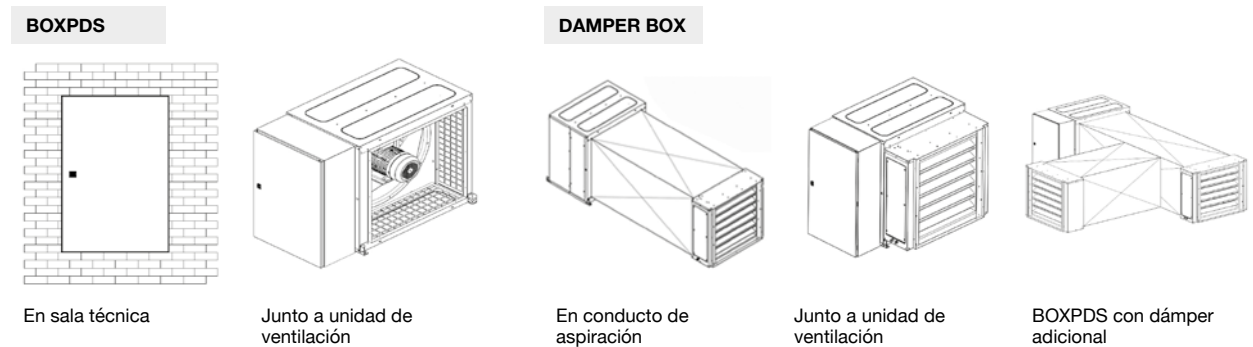

Se pueden usar 2 dampers instalando dos puntos de aspiración alejados del ventilador, de forma que en caso de detección de humos en un punto de aspiración éste se cerrará y se mantiene el segundo dámper abierto para asegurar la entrada de aire limpio al espacio a proteger (vía de evacuación libre de humo).

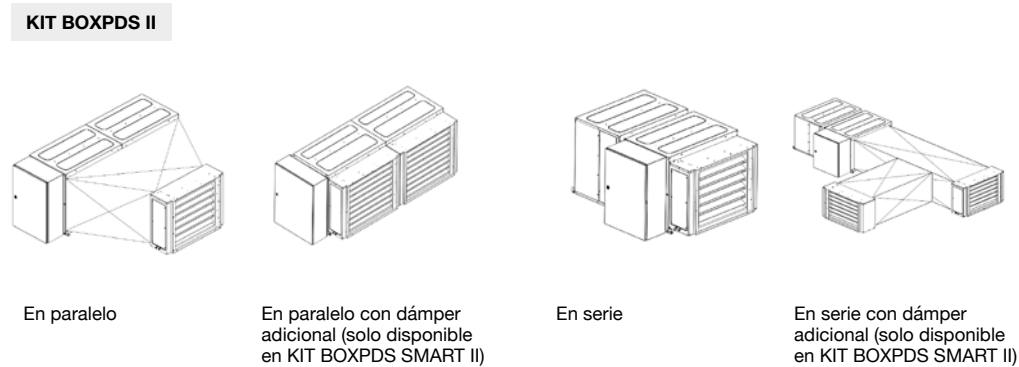

Accesorios



PDS LOBBY CONTROL



DAMPER BOX

KIT BOXPDS SMART

Equipos de presurización para vías de evacuación con control avanzado, diseñados según la norma europea EN 12101-6

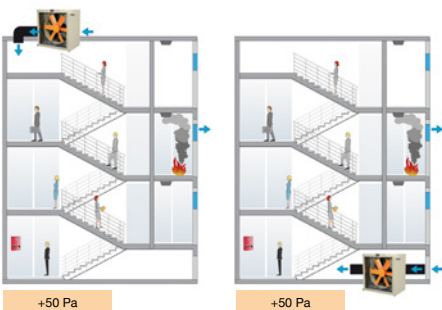

Equipos de presurización de vías de evacuación en caso de incendio diseñados según la norma europea EN 12101-6. El KIT BOXPDS SMART regula de forma automática el flujo de aire y es capaz de mantener los 50 Pa de sobrepresión aún con presencia de fugas en la instalación. El sistema es capaz de mantener la sobrepresión (Pressure criteria) y alcanzar el 90% del caudal requerido dentro de los 3 segundos siguientes a la apertura o cierre de una puerta (Airflow criteria).

Incluyendo certificación de ensayos de comportamiento dinámico, compatibilidad electromagnética, resistencia ambiental y grado de protección IP.

Modelo de utilidad: ES 1 226 660 U.

KIT BOXPDS SMART

- Equipo con control avanzado, consta del cuadro de control BOXPDS SMART, cuadro de mandos externo, una unidad de ventilación CJHCH y un DAMPER BOX SMART con detector óptico de humos incorporado.

BOXPDS SMART

- Variador de frecuencia Inverter.
- Sonda de presión diferencial de gran precisión.
- Cuadro eléctrico con protecciones magnetotérmicas e indicación de fallo en la alimentación general.
- Control electrónico para gestión de alarmas, mantenimiento, puerto ModBUS RTU para conexión a sistemas BMS (Building Management Systems) y control de DAMPER BOX SMART.

- Fuente de alimentación certificada con baterías para asegurar la alimentación de los equipos de control en caso de fallo en la red eléctrica.
- Quick set up para configuración intuitiva.
- Posibilidad de controlar 3 tomas de aire motorizadas del tipo DAMPER BOX SMART, HATCH o WALL.
- Detector de humos con Reset automático.
- Modo de presurización o despresurización/extracción.
- Posibilidad de conectar varios sensores de presión para cajas de escalera de gran tamaño y elegir el modo de control: Máximo, mínimo o promedio.
- Conexión de sensores externos: Humedad, temperatura y viento.
- Incluye programación horaria para activar ventilación diaria.

Cuadro de mandos:

- Cuadro de mandos externo con pantalla táctil para la visualización de la presión a tiempo real, configuración y calibración del sistema, pilotos de estado y activación manual del sistema.
- Posibilidad de conectar hasta 3 KIT BOXPDS SMART.
- Selector Auto-Manual-Off.
- Selector Reset alarma incendio.
- Selector Test.

Bajo demanda:

- Sistema conmutación automático para ventilador de reserva (ver serie KIT BOXPDS SMART II).



- Fácil instalación.
- Solución compacta y autónoma.
- Fácil puesta en marcha.
- Instalación segura y funcional.

Código de pedido

KIT BOXPDS SMART

800

4T

5.5

KIT BOXPDS SMART: Equipos de presurización para vías de evacuación con control avanzado, diseñados según la norma europea EN 12101-6

KIT BOXPDS SMART II: Equipos de presurización para vías de evacuación con control avanzado y ventilador de reserva, diseñados según la norma europea EN 12101-6

Diámetro hélice en cm

Número de polos motor
4=1400 r/min 50 Hz

T = Trifásico

Potencia motor (CV)

Características técnicas

Modelo	Velocidad	Alimentación	Intensidad máxima admisible (A)	Potencia instalada	Caudal máximo	Nivel presión sonora	Peso aprox.
	(r/min)	(V) (Hz)	400V	(kW)	(m³/h)	dB (A)	(Kg)
KIT BOXPDS SMART-710-4T-1.5 IE3	1400	380-480 V 50/60 Hz	4,75	1,1	19770	75	188
KIT BOXPDS SMART-710-4T-2 IE3	1430	380-480 V 50/60 Hz	6,25	1,5	21090	75	196
KIT BOXPDS SMART-710-4T-3 IE3	1445	380-480 V 50/60 Hz	8,20	2,2	23970	78	205
KIT BOXPDS SMART-800-4T-3 IE3	1445	380-480 V 50/60 Hz	8,20	2,2	27940	79	213
KIT BOXPDS SMART-800-4T-4 IE3	1445	380-480 V 50/60 Hz	10,05	3,0	32720	80	215
KIT BOXPDS SMART-800-4T-5.5 IE3	1440	380-480 V 50/60 Hz	12,65	4,0	37440	81	220
KIT BOXPDS SMART-900-4T-7.5 IE3	1440	380-480 V 50/60 Hz	15,20	5,5	47550	88	314
KIT BOXPDS SMART-900-4T-10 IE3	1455	380-480 V 50/60 Hz	20,30	7,5	53120	89	331
KIT BOXPDS SMART-1000-4T-10 IE3	1455	380-480 V 50/60 Hz	20,30	7,5	58560	90	339
KIT BOXPDS SMART-1000-4T-15 IE3	1460	380-480 V 50/60 Hz	28,30	11,0	68000	91	371
KIT BOXPDS SMART-1000-4T-20 IE3	1460	380-480 V 50/60 Hz	36,60	15,0	71850	92	382

Se pueden suministrar con KIT BOXPDS SMART II para ventilador de reserva (se añade una segunda unidad de impulsión equivalente a la del KIT BOXPDS SMART).

Dimensiones mm

KIT BOXPDS SMART

	A	B	C	D	E	F	G	H	I	J	K	L	O
KIT BOXPDS SMART-710/800	1400	400	1000	1000	350	1000	650	995	600	850	650	850	1000
KIT BOXPDS SMART-900/1000	1600	400	1200	1125	350	1200	750	1195	800	1050	750	1050	1200

BOXPDS SMART			DAMPER BOX SMART			CJHCH					
	C	B	I		E	J	H		O	K	L
BOXPDS SMART-710/800	1000	400	600	DAMPER BOX SMART 71/80	350	850	995	CJHCH-71/80	1000	650	850
BOXPDS SMART-900/1000	1200	400	800	DAMPER BOX SMART 90/100	350	1050	1195	CJHCH-90/100	1200	750	1050

Ejemplo de aplicación

BOXPDS SMART

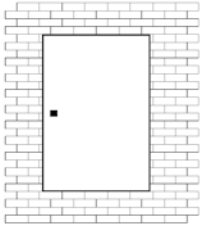

En sala técnica

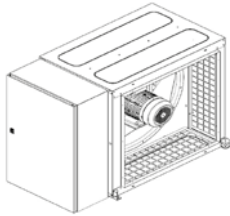

Junto a unidad de ventilación

DAMPER BOX SMART

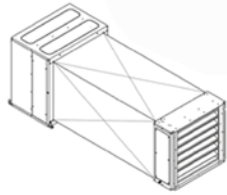

En conducto de aspiración

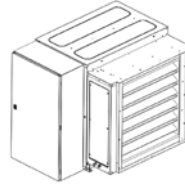

Junto a unidad de ventilación

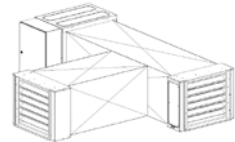

BOXPDS con dámper adicional

Se pueden usar 2 dampers instalando dos puntos de aspiración alejados del ventilador, de forma que en caso de detección de humos en un punto de aspiración éste se cerrará y se mantiene el segundo dámper abierto para asegurar la entrada de aire limpio al espacio a proteger (vía de evacuación libre de humo).

KIT BXPDS SMART II

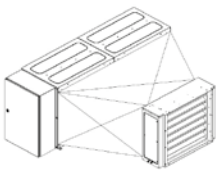

En paralelo

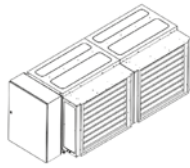

En paralelo con dámper adicional (solo disponible en KIT BXPDS SMART II)

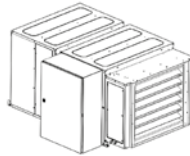

En serie

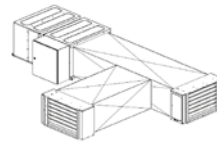

En serie con dámper adicional (solo disponible en KIT BXPDS SMART II)

Accesorios



PDS LOBBY CONTROL



DAMPER BOX SMART

HATCH PDS



Equipos de presurización de vías de evacuación en caso de incendio, diseñados según la norma europea EN 12101-6



+50 Pa

HATCH PDS

- Consta de una unidad de ventilación HATCH con apertura de compuerta motorizada y de un cuadro de control BOXPDS.
- Estructura de gran robustez para resistir severas condiciones climáticas.
- Estructura del equipo en chapa galvanizada anticorrosiva.
- Diseñado para asegurar la estanqueidad a la entrada de agua.
- Aislamiento térmico para evitar pérdidas de aire caliente en invierno.
- Zócalo de adaptación para la correcta y fácil instalación en el tejado.
- Detector de humo analógico incorporado.
- Modelo de utilidad: ES 1 226 660 U.

Sistema de apertura:

- Brazo motorizado de apertura, con mecanismo encapsulado IP65.
- Sistema reforzado y garantizado con más de 11.000 ciclos.
- Carga de nieve SL 1000.

Ventilador:

- Extractores serie HCT.
- Envoltente tubular en chapa de acero con tratamiento anticorrosivo en resina de poliéster.
- Hélice en fundición de aluminio.

Motor:

- Motores con eficiencia IE3 para potencias iguales o superiores a 0,75 kW, excepto monofásicos, 2 velocidades y 8 polos.
- Motores clase F con rodamientos a bolas y protección IP55.
- Trifásico 230/400 V 50 Hz (hasta 4 kW) y 400/690 V 50 Hz (potencias superiores a 4 kW).
- Temperatura de trabajo: -25 °C +50 °C.

Acabado:

- Anticorrosivo en chapa de acero galvanizado.

Bajo demanda:

- Equipados con ventiladores certificados F300 y F400.
- Equipos de presurización reversibles para evacuación de humos en caso de necesidad.
- Acabado con pintura anticorrosiva en resina de poliéster.

BOXPDS

- Variador de frecuencia Inverter.
- Sonda de presión diferencial de gran precisión.
- Cuadro eléctrico con protecciones magnetotérmicas e indicación de fallo en la alimentación general.
- Control electrónico para gestión de alarmas, mantenimiento, puerto ModBUS RTU para conexión a sistemas BMS (Building Management Systems).
- Fuente de alimentación certificada con baterías para asegurar la alimentación de los equipos de control en caso de fallo en la red eléctrica.
- Incluye programación horaria para activar ventilación diaria.

Cuadro de mandos:

- Cuadro de mandos externo para la visualización de la presión a tiempo real, pilotos de alarmas y activación manual del sistema.



Código de pedido

HATCH PDS	—	80	—	4T	—	5.5	—	G
HATCH PDS: Equipos de presurización de vías de evacuación en caso de incendio, diseñados según la norma europea EN 12101-6		Tamaño		Número de polos motor 2=2900 r/min 50 Hz 4=1400 r/min 50 Hz 6=900 r/min 50 Hz	T = Trifásico	Potencia motor (CV)		Acabado G=galvanizado P=pintado color especial

Características técnicas

Modelo	Velocidad (r/min)	Intensidad máxima admisible (A)			Potencia instalada (kW)	Ángulo inclinación palas (°)	Caudal máximo (m³/h)	Nivel de presión sonora dB (A)		Peso aprox. (Kg)
		230V	400V	690V				Aspiración	Descarga	
HATCH PDS-40-2T-1 IE3	2850	2,80	1,62		0,75	16	6100	62	62	184
HATCH PDS-40-2T-1.5 IE3	2880	4,03	2,34		1,10	20	7040	61	61	188
HATCH PDS-45-2T-2 IE3	2880	5,34	3,07		1,50	16	9400	61	61	193
HATCH PDS-45-2T-3 IE3	2840	7,32	4,21		2,20	22	11325	61	61	194
HATCH PDS-50-2T-4 IE3	2880	10,00	5,77		3,00	16	13860	66	66	206
HATCH PDS-50-2T-5.5 IE3	2900	13,00	7,50		4,00	20	15918	66	66	222
HATCH PDS-56-2T-5.5 IE3	2870	13,00	7,50		4,00	16	18820	68	68	226
HATCH PDS-56-2T-7.5 IE3	2910		10,10	5,86	5,50	22	22510	68	68	237
HATCH PDS-56-4T-2 IE3	1440	5,41	3,11		1,50	36	15025	54	54	205
HATCH PDS-63-4T-3 IE3	1425	7,93	4,56		2,20	32	22170	58	58	262
HATCH PDS-63-4T-4 IE3	1430	10,70	6,15		3,00	38	24240	59	59	271
HATCH PDS-63-6T-1 IE3	940	3,36	1,93		0,75	38	15890	48	48	252
HATCH PDS-80-4T-3 IE3	1425	7,93	4,56		2,20	12	25460	65	65	280
HATCH PDS-80-4T-4 IE3	1430	10,70	6,15		3,00	16	30270	64	64	289
HATCH PDS-80-4T-5.5 IE3	1440	13,90	8,00		4,00	18	32770	63	63	295
HATCH PDS-80-4T-7.5 IE3	1460		10,30	5,97	5,50	26	39640	63	63	311
HATCH PDS-80-6T-1.5 IE3	945	4,68	2,69		1,10	18	21470	53	53	279
HATCH PDS-80-6T-2 IE3	945	6,43	3,70		1,50	26	25970	54	54	288
HATCH PDS-90-4T-7.5 IE3	1460		10,30	5,97	5,50	18	46140	67	67	392
HATCH PDS-90-4T-10 IE3	1460		13,90	8,06	7,50	22	50140	66	66	403
HATCH PDS-90-4T-15 IE3	1460		20,90	12,10	11,00	30	59390	68	68	456
HATCH PDS-90-6T-3 IE3	950	9,08	5,22		2,20	24	34000	56	56	365
HATCH PDS-90-6T-4 IE3	970	12,00	6,91		3,00	30	38910	59	59	391
HATCH PDS-100-4T-10 IE3	1460		13,90	8,06	7,50	16	57420	69	69	413
HATCH PDS-100-4T-15 IE3	1460		20,90	12,10	11,00	22	66300	69	69	466
HATCH PDS-100-6T-5.5 IE3	970	15,60	8,99		4,00	26	47780	60	60	413
HATCH PDS-100-6T-7.5 IE3	970		11,20	6,49	5,50	32	53520	62	62	420

* Los valores de los niveles sonoros, son presiones en dB(A) medidos a 10 metros, en campo libre.

Características técnicas del exutorio dinámico según normas EN-12101-3

Modelo	Homologación (°C)	Clase aislamiento motor	Durabilidad	Temperatura ambiente mínima	Carga de viento		Carga de nieve
					(Pa)	(Pa)	
HATCH PDS	-	Clase F	RE 11000	-25	WL 200	SL 1000	

Características acústicas

Espectro de potencia sonora Lw(A) en dB(A) por banda de frecuencia en Hz

Valores tomados a la aspiración con caudal máximo

	63	125	250	500	1000	2000	4000	8000
40-2-1	48	64	76	84	89	87	83	76
40-2-1.5	47	63	75	83	88	86	82	75
45-2-2	47	60	74	86	87	86	82	74
45-2-3	47	64	74	81	88	86	83	75
50-2-4	58	74	84	91	92	89	88	89
50-2-5.5	58	74	84	91	92	89	88	89
56-2-5.5	53	66	84	92	94	93	88	81
56-2-7.5	53	66	84	92	94	93	88	81
56-4-2	52	64	73	79	79	79	73	65
63-4-3	56	68	77	83	83	83	77	69
63-4-4	57	69	78	84	84	84	78	70
63-6-1	49	59	69	73	74	72	65	57
80-4-3	55	71	84	91	91	88	82	74
80-4-4	54	70	83	90	90	87	81	73
80-4-5.5	53	69	82	89	89	86	80	72
80-4-7.5	53	69	82	89	89	86	80	72
80-6-1.5	53	68	75	78	79	76	70	62
80-6-2	59	69	75	79	80	78	73	65
90-4-7.5	59	75	86	92	93	91	86	78
90-4-10	58	74	85	91	92	90	85	77
90-4-15	60	76	87	93	94	92	87	79
90-6-3	52	67	78	82	82	78	71	63
90-6-4	60	70	80	85	85	82	76	68
100-4-10	64	80	87	94	95	93	89	81
100-4-15	71	83	87	93	94	94	91	83
100-6-5.5	57	72	82	85	86	83	75	67
100-6-7.5	59	74	84	87	88	85	77	69

Valores tomados a la descarga con caudal máximo

	63	125	250	500	1000	2000	4000	8000
40-2-1	48	64	76	84	89	87	83	76
40-2-1.5	47	63	75	83	88	86	82	75
45-2-2	47	60	74	86	87	86	82	74
45-2-3	47	64	74	81	88	86	83	75
50-2-4	58	74	84	91	92	89	88	89
50-2-5.5	58	74	84	91	92	89	88	89
56-2-5.5	53	66	84	92	94	93	88	81
56-2-7.5	53	66	84	92	94	93	88	81
56-4-2	52	64	73	79	79	79	73	65
63-4-3	56	68	77	83	83	83	77	69
63-4-4	57	69	78	84	84	84	78	70
63-6-1	49	59	69	73	74	72	65	57
80-4-3	55	71	84	91	91	88	82	74
80-4-4	54	70	83	90	90	87	81	73
80-4-5.5	53	69	82	89	89	86	80	72
80-4-7.5	53	69	82	89	89	86	80	72
80-6-1.5	53	68	75	78	79	76	70	62
80-6-2	59	69	75	79	80	78	73	65
90-4-7.5	59	75	86	92	93	91	86	78
90-4-10	58	74	85	91	92	90	85	77
90-4-15	60	76	87	93	94	92	87	79
90-6-3	52	67	78	82	82	78	71	63
90-6-4	60	70	80	85	85	82	76	68
100-4-10	64	80	87	94	95	93	89	81
100-4-15	71	83	87	93	94	94	91	83
100-6-5.5	57	72	82	85	86	83	75	67
100-6-7.5	59	74	84	87	88	85	77	69

Dimensiones mm

HATCH PDS

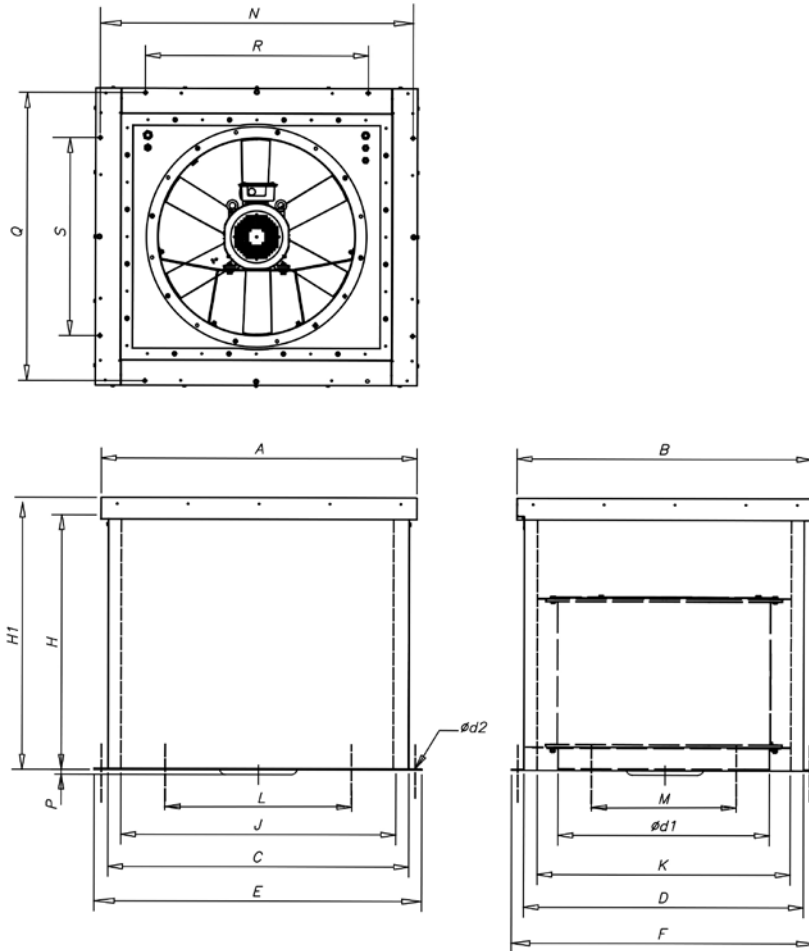

	A	B	C	D	Ød1	E	F	H	H1	J	K	L	M	N	P	Q	R	S	Ød2
HATCH/PDS-40	1100	1000	1020	920	400	1100	1000	900	1000	900	800	700	600	1065	-	965	700	600	13
HATCH/PDS-45	1100	1000	1020	920	450	1100	1000	900	1000	900	800	700	600	1065	-	965	700	600	13
HATCH/PDS-50	1100	1000	1020	920	500	1100	1000	900	1000	900	800	700	600	1065	-	965	700	600	13
HATCH/PDS-56	1100	1000	1020	920	560	1100	1000	900	1000	900	800	700	600	1065	-	965	700	600	13
HATCH/PDS-63	1300	1200	1220	1120	630	1300	1200	900	1000	1100	1000	900	800	1265	-	1165	900	800	13
HATCH/PDS-80	1300	1200	1220	1120	800	1300	1200	900	1000	1100	1000	900	800	1265	-	1165	900	800	13
HATCH/PDS-90	1500	1400	1420	1320	900	1500	1400	900	1000	1300	1200	1100	1000	1465	-	1365	1100	1000	13
HATCH/PDS-90-4T-15	1500	1400	1420	1320	900	1500	1400	900	1000	1300	1200	1100	1000	1465	38	1365	1100	1000	13
HATCH/PDS-100	1500	1400	1420	1320	1000	1500	1400	900	1000	1300	1200	1100	1000	1465	-	1365	1100	1000	13
HATCH/PDS-100-4T-15	1500	1400	1420	1320	1000	1500	1400	900	1000	1300	1200	1100	1000	1465	80	1365	1100	1000	13

BOXPDS

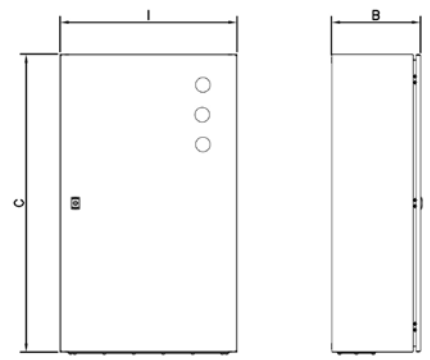

	I	B	C	Tamaño
BOXPDS (0,75kW...4kW)	600	300	1000	1
BOXPDS (5,5kW...15kW)	800	300	1200	2

KIT BOXSMART KIT BOXSMART II

Sistema de presurización de escaleras o vías de evacuación. Mantiene una presión diferencial de 50 Pa en una sola etapa, diseñados según la norma europea EN 12101-6



El buen funcionamiento de los sistemas de presurización depende no solo del buen diseño de los mismos, sino también de la buena regulación que realice el sistema, por lo que es de vital importancia contar con elementos de regulación calibrados y de gran precisión, que permitan simultanear las dos situaciones presentes en caso de incendio, de forma rápida y estable.

KIT BOXSMART

- Kit de sobrepresión de escaleras, formado por un cuadro de control (BOXSMART), una unidad de impulsión (CJHCH o CJBBD), para la presurización de las escaleras y vías de evacuación, y un control integrado de compuertas motorizadas con detector de humos (Compatible con DAMPER BOX SMART).

KIT BOXSMART II

- Kit de sobrepresión con ventilador de reserva, formado por un cuadro de

control (BOXSMART II), que incorpora un sistema de conmutación automático para mantener la sobrepresión en caso de fallo del ventilador principal, y un control integrado de compuertas motorizadas con detector de humos (Compatible con DAMPER BOX SMART).

CM-SMART: Cuadro de mandos externo para bomberos

- El CM-SMART indica el estado del sistema y da la opción a los bomberos de activar o parar el sistema manualmente a través de su selector. Se recomienda instalar este cuadro en el acceso principal de la zona protegida por el sistema de presurización.
- Este equipo no va incluido en el KIT BOXSMART.
- Los modelos BOXSMART y BOXSMART II son compatibles con CM-SMART.



- Fácil instalación.
- Solución compacta y autónoma.
- Fácil puesta en marcha.
- Instalación segura y funcional.

Código de pedido

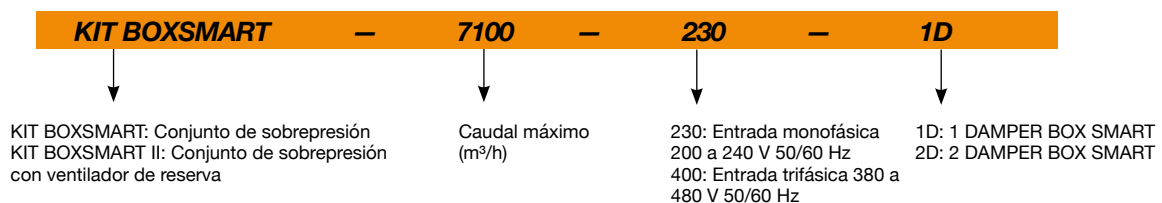

Características técnicas

Modelo	Potencia (kW)	Alimentación (V) (Hz)	Salida (V)	Caudal máximo (m ³ /h)	Unidad de impulsión
KIT BOXSMART-2880-230V-1D	0,37	200 a 240 V 50/60 Hz	230 V 50/60 Hz	2880	CJBD-2828-4M 1/2
KIT BOXSMART-7100-230V-1D	0,37	200 a 240 V 50/60 Hz	230 V 50/60 Hz	7100	CJHCH-45-4T-0.5 IE3
KIT BOXSMART-7800-230V-1D	1,10	200 a 240 V 50/60 Hz	230 V 50/60 Hz	7800	CJBD-3333-6T 1 1/2
KIT BOXSMART-12900-230V-1D	0,75	200 a 240 V 50/60 Hz	230 V 50/60 Hz	12900	CJHCH-56-4T-1 IE3
KIT BOXSMART-17000-230V-1D	1,10	200 a 240 V 50/60 Hz	230 V 50/60 Hz	17000	CJHCH-63-4T-1.5 IE3
KIT BOXSMART-7800-400V-1D	1,10	380 a 480 V 50/60 Hz	400 V 50/60 Hz	7800	CJBD-3333-6T 1 1/2
KIT BOXSMART-12900-400V-1D	0,75	380 a 480 V 50/60 Hz	400 V 50/60 Hz	12900	CJHCH-56-4T-1 IE3
KIT BOXSMART-17000-400V-1D	1,10	380 a 480 V 50/60 Hz	400 V 50/60 Hz	17000	CJHCH-63-4T-1.5 IE3

Características técnicas

Modelo	Potencia	Alimentación	Salida	Caudal máximo	Unidad de impulsión
	(kW)	(V) (Hz)	(V)	(m³/h)	
KIT BOXSMART-21100-400V-1D	1,50	380 a 480 V 50/60 Hz	400 V 50/60 Hz	22100	CJHCH-71-4T-2 IE3
KIT BOXSMART-2880-230V-2D	0,37	200 a 240 V 50/60 Hz	230 V 50/60 Hz	2880	CJBD-2828-4M 1/2
KIT BOXSMART-7100-230V-2D	0,37	200 a 240 V 50/60 Hz	230 V 50/60 Hz	7100	CJHCH-45-4T-0.5 IE3
KIT BOXSMART-7800-230V-2D	1,10	200 a 240 V 50/60 Hz	230 V 50/60 Hz	7800	CJBD-3333-6T 1 1/2
KIT BOXSMART-12900-230V-2D	0,75	200 a 240 V 50/60 Hz	230 V 50/60 Hz	12900	CJHCH-56-4T-1 IE3
KIT BOXSMART-17000-230V-2D	1,10	200 a 240 V 50/60 Hz	230 V 50/60 Hz	17000	CJHCH-63-4T-1.5 IE3
KIT BOXSMART-7800-400V-2D	1,10	380 a 480 V 50/60 Hz	400 V 50/60 Hz	7800	CJBD-3333-6T 1 1/2
KIT BOXSMART-12900-400V-2D	0,75	380 a 480 V 50/60 Hz	400 V 50/60 Hz	12900	CJHCH-56-4T-1 IE3
KIT BOXSMART-17000-400V-2D	1,10	380 a 480 V 50/60 Hz	400 V 50/60 Hz	17000	CJHCH-63-4T-1.5 IE3
KIT BOXSMART-21100-400V-2D	1,50	380 a 480 V 50/60 Hz	400 V 50/60 Hz	22100	CJHCH-71-4T-2 IE3

* La potencia de salida se reduce un 20% cuando los equipos trabajan en el rango inferior de tensión de alimentación. Los mismos modelos, excepto los modelos FLAP, se pueden suministrar con KIT BOXSMART II para ventilador de reserva (se añade una segunda unidad de impulsión equivalente a la del KIT BOXSMART).

Dimensiones mm

CJBD

	A	B	C	D	E	F	G	K	L
CJBD-2828	550	575	600	479	504	104	177	330	294
CJBD-3333	650	650	700	554	604	105	198	392	347

CJHCH

	A	C	D1
CJHCH-45	700	550	565
CJHCH-56/63	825	550	690
CJHCH-71	1000	650	850

Ejemplo de aplicación

Método de control de humo por sobrepresión

Este sistema consiste en la presurización mediante inyección de aire en los habitáculos que son utilizados como vías de evacuación de personas en caso de incendio, tales como cajas de escalera, pasillos, corredores, elevadores, etc., sobre todo en edificios de altura con gran ocupación.

Este método está basado en el control del humo mediante la velocidad del aire y la barrera artificial que crea la sobrepresión del aire sobre el humo, para que éste no pueda entrar en las vías de evacuación.

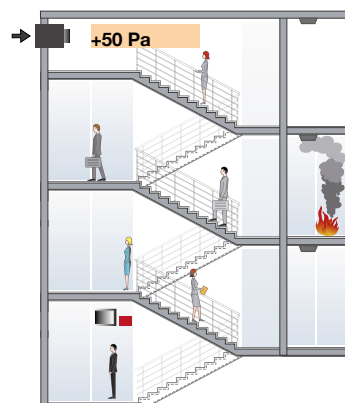

BOXSMART

Cuadro de control para un ventilador

BOXSMART II

Cuadro de control con ventilador de reserva



El cuadro de control BOXSMART incluye:

- Variador de frecuencia programado a 50 Pa y sonda de presión diferencial de gran precisión.
- Conexión externa para cuadro de mandos para uso exclusivo de bomberos.
- Magnetotérmico.
- Piloto indicador de estado: Operativo, Alarma, Activación por fuego y Marcha.
- Cuadro de mandos incorporado con selector TEST para mantenimiento y selector exclusivo para bomberos 0-AUTO-MANUAL.
- Protocolo de funcionamiento en modo seguro en caso de fallo de sonda de presión diferencial y rearme automático del sistema en caso de fallo.
- Conexión de señales de estado mediante contactos libres de potencial (FALLO, MARCHA y ACTIVACIÓN FUEGO) y conexión a sistemas BMS mediante Modbus RTU para la monitorización de los equipos.
- Memoria del último estado de activación para mayor seguridad reseteable desde selector RESET en cuadro de mandos o mediante señal externa.
- Conexión externa para uso de ventilación diaria mediante accesorio SI-CALENDAR.

- Envolvente metálica con protección IP66 y cerradura mediante llave de servicio.
- Habilitado para la gestión de motores asíncronos, IPM o RM.
- Listo para funcionar y desempeñar su función sobre el control de la presión de la instalación.
- Solo se debe conectar la línea de alimentación, el ventilador de impulsión y la señal de incendio.
- Diferentes rangos de tensión de entrada y potencia bajo demanda.
- Control integrado de compuertas motorizadas con detector de humos (Compatible con DAMPER BOX SMART).

Opciones:

- BOXSMART EC: Cuadro de control para un ventilador motor EC.
- BOXSMART: Cuadro de control para un ventilador.
- BOXSMART II: Cuadro de control con ventilador de reserva.
- BOXSMART FLAP: Cuadro de control con ventilador de compuerta.

Código de pedido

BOXSMART	—	1.1	—	230	—	M	—	1D
↓		↓		↓		↓		↓
BOXSMART: Cuadro de control para un ventilador BOXSMART II: Cuadro de control con ventilador de reserva		Potencia (kW)		Tensión entrada		M: Entrada monofásica T: Entrada trifásica		1D: 1 DAMPER BOX SMART 2D: 2 DAMPER BOX SMART

Características técnicas y dimensiones

BOXSMART								
Modelo	Potencia	Alimentación	Salida	Intensidad máx. salida	Tamaño	Medidas	Peso aprox.	
	(kW)	(V) (Hz)	(V)	(A)		(largo x ancho x fondo)	(Kg)	
BOXSMART-0.37-230V 50/60Hz-M-T-1D	0,37	200 a 240 V 50/60 Hz	230 V 50/60 Hz	2,3	2	400x500x250	11	
BOXSMART-0.75-230V 50/60Hz-M-T-1D	0,75	200 a 240 V 50/60 Hz	230 V 50/60 Hz	4,3	2	400x500x250	11	
BOXSMART-1.5-230V 50/60Hz-T-T-1D	1,50	200 a 240 V 50/60 Hz	230 V 50/60 Hz	7,0	2	400x500x250	11	
BOXSMART-0.75-400V 50/60Hz-T-T-1D	0,75	380 a 480 V 50/60 Hz	400 V 50/60 Hz	2,2	2	400x500x250	11	
BOXSMART-1.5-400V 50/60Hz-T-T-1D	1,50	380 a 480 V 50/60 Hz	400 V 50/60 Hz	4,1	2	400x500x250	11	
BOXSMART-2.2-400V 50/60Hz-T-T-1D	2,20	380 a 480 V 50/60 Hz	400 V 50/60 Hz	5,8	3	400x600x250	18	
BOXSMART-4-400V 50/60Hz-T-T-1D	4,00	380 a 480 V 50/60 Hz	400 V 50/60 Hz	9,5	3	400x600x250	18	

Características técnicas y dimensiones

BOXSMART

Modelo	Potencia (kW)	Alimentación (V) (Hz)	Salida (V)	Intensidad máx. salida (A)	Tamaño	Medidas (largo x ancho x fondo)	Peso aprox. (Kg)
BOXSMART-5.5-400V 50/60Hz-T-T-1D	5,50	380 a 480 V 50/60 Hz	400 V 50/60 Hz	14,0	4	500x700x250	21
BOXSMART-7.5-400V 50/60Hz-T-T-1D	7,50	380 a 480 V 50/60 Hz	400 V 50/60 Hz	18,0	4	500x700x250	21
BOXSMART-11-400V 50/60Hz-T-T-1D	11,00	380 a 480 V 50/60 Hz	400 V 50/60 Hz	24,0	4	500x700x250	22
BOXSMART-0.37-230V 50/60Hz-M-T-2D	0,37	200 a 240 V 50/60 Hz	230 V 50/60 Hz	2,3	3	400x600x250	11
BOXSMART-0.75-230V 50/60Hz-M-T-2D	0,75	200 a 240 V 50/60 Hz	230 V 50/60 Hz	4,3	3	400x600x250	11
BOXSMART-1.5-230V 50/60Hz-T-T-2D	1,50	200 a 240 V 50/60 Hz	230 V 50/60 Hz	7,0	3	400x600x250	11
BOXSMART-0.75-400V 50/60Hz-T-T-2D	0,75	380 a 480 V 50/60 Hz	400 V 50/60 Hz	2,2	3	400x600x250	11
BOXSMART-1.5-400V 50/60Hz-T-T-2D	1,50	380 a 480 V 50/60 Hz	400 V 50/60 Hz	4,1	3	400x600x250	11
BOXSMART-2.2-400V 50/60Hz-T-T-2D	2,20	380 a 480 V 50/60 Hz	400 V 50/60 Hz	5,8	4	500x700x250	18
BOXSMART-4-400V 50/60Hz-T-T-2D	4,00	380 a 480 V 50/60 Hz	400 V 50/60 Hz	9,5	4	500x700x250	18
BOXSMART-5.5-400V 50/60Hz-T-T-2D	5,50	380 a 480 V 50/60 Hz	400 V 50/60 Hz	14,0	5	600x800x250	21
BOXSMART-7.5-400V 50/60Hz-T-T-2D	7,50	380 a 480 V 50/60 Hz	400 V 50/60 Hz	18,0	5	600x800x250	21
BOXSMART-11-400V 50/60Hz-T-T-2D	11,00	380 a 480 V 50/60 Hz	400 V 50/60 Hz	24,0	5	600x800x250	22

BOXSMART II

Para sistemas con ventilador de reserva. Los ventiladores nunca funcionan simultáneamente.

Modelo	Potencia (kW)	Alimentación (V) (Hz)	Salida (V)	Intensidad máx. salida (A)	Tamaño	Medidas (largo x ancho x fondo)	Peso aprox. (Kg)
BOXSMART II-0.37-230V 50/60Hz-M-T-1D	0,37	200 a 240 V 50/60 Hz	230 V 50/60 Hz	2,3	4	500x700x250	11
BOXSMART II-0.75-230V 50/60Hz-M-T-1D	0,75	200 a 240 V 50/60 Hz	230 V 50/60 Hz	4,3	4	500x700x250	11
BOXSMART II-1.5-230V 50/60Hz-T-T-1D	1,50	200 a 240 V 50/60 Hz	230 V 50/60 Hz	7,0	4	500x700x250	11
BOXSMART II-0.75-400V 50/60Hz-T-T-1D	0,75	380 a 480 V 50/60 Hz	400 V 50/60 Hz	2,2	4	500x700x250	11
BOXSMART II-1.5-400V 50/60Hz-T-T-1D	1,50	380 a 480 V 50/60 Hz	400 V 50/60 Hz	4,1	4	500x700x250	11
BOXSMART II-2.2-400V 50/60Hz-T-T-1D	2,20	380 a 480 V 50/60 Hz	400 V 50/60 Hz	5,8	5	600x800x250	18
BOXSMART II-4-400V 50/60Hz-T-T-1D	4,00	380 a 480 V 50/60 Hz	400 V 50/60 Hz	9,5	5	600x800x250	18
BOXSMART II-5.5-400V 50/60Hz-T-T-1D	5,50	380 a 480 V 50/60 Hz	400 V 50/60 Hz	14,0	6	800x800x250	21
BOXSMART II-7.5-400V 50/60Hz-T-T-1D	7,50	380 a 480 V 50/60 Hz	400 V 50/60 Hz	18,0	6	800x800x250	21
BOXSMART II-11-400V 50/60Hz-T-T-1D	11,00	380 a 480 V 50/60 Hz	400 V 50/60 Hz	24,0	6	800x800x250	22
BOXSMART II-0.37-230V 50/60Hz-M-T-2D	0,37	200 a 240 V 50/60 Hz	230 V 50/60 Hz	2,3	4	500x700x250	11
BOXSMART II-0.75-230V 50/60Hz-M-T-2D	0,75	200 a 240 V 50/60 Hz	230 V 50/60 Hz	4,3	4	500x700x250	11
BOXSMART II-1.5-230V 50/60Hz-T-T-2D	1,50	200 a 240 V 50/60 Hz	230 V 50/60 Hz	7,0	4	500x700x250	11
BOXSMART II-0.75-400V 50/60Hz-T-T-2D	0,75	380 a 480 V 50/60 Hz	400 V 50/60 Hz	2,2	4	500x700x250	11
BOXSMART II-1.5-400V 50/60Hz-T-T-2D	1,50	380 a 480 V 50/60 Hz	400 V 50/60 Hz	4,1	4	500x700x250	11
BOXSMART II-2.2-400V 50/60Hz-T-T-2D	2,20	380 a 480 V 50/60 Hz	400 V 50/60 Hz	5,8	5	600x800x250	18
BOXSMART II-4-400V 50/60Hz-T-T-2D	4,00	380 a 480 V 50/60 Hz	400 V 50/60 Hz	9,5	5	600x800x250	18
BOXSMART II-5.5-400V 50/60Hz-T-T-2D	5,50	380 a 480 V 50/60 Hz	400 V 50/60 Hz	14,0	6	800x800x250	21
BOXSMART II-7.5-400V 50/60Hz-T-T-2D	7,50	380 a 480 V 50/60 Hz	400 V 50/60 Hz	18,0	6	800x800x250	21
BOXSMART II-11-400V 50/60Hz-T-T-2D	11,00	380 a 480 V 50/60 Hz	400 V 50/60 Hz	24,0	6	800x800x250	22

Conexiones

*Todas las conexiones se realizan en la parte superior del cuadro.

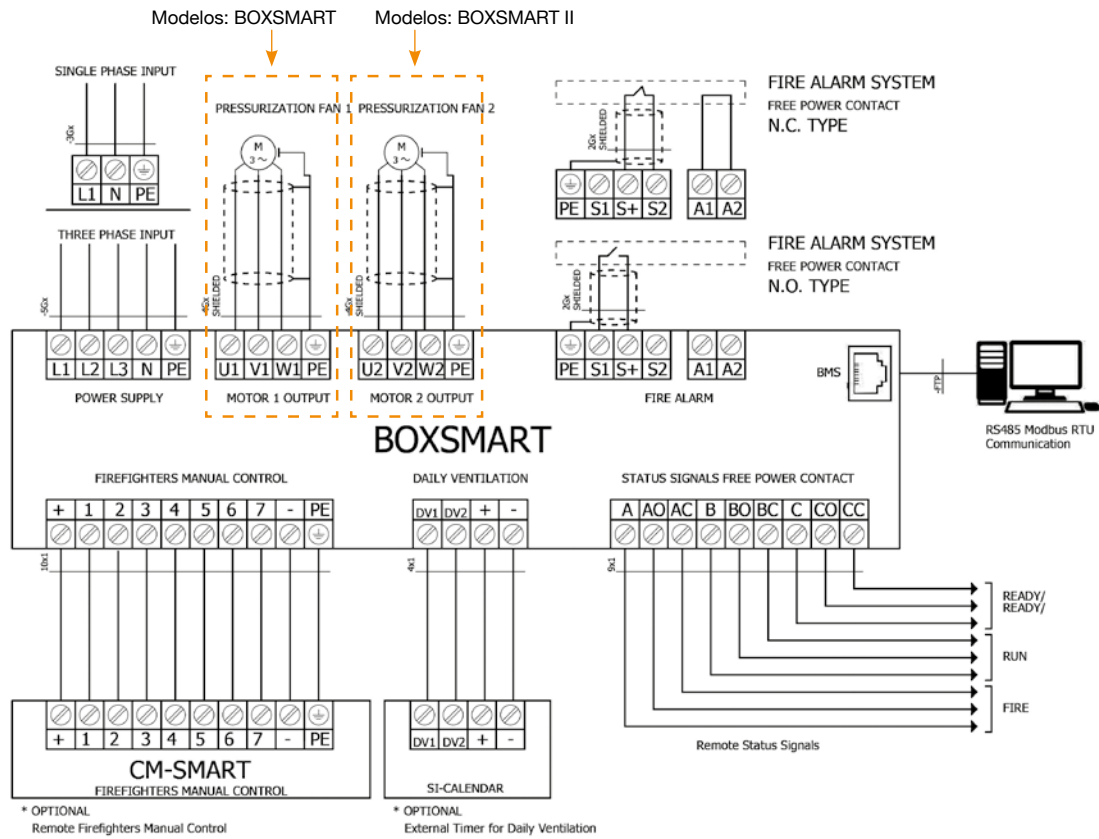

Accesorios



CM-SMART



SI-CALENDAR



DAMPER BOX SMART

KIT BOXSMART EC



Sistema de presurización de escaleras o vías de evacuación. Mantiene una presión diferencial de 50 Pa en una sola etapa, diseñados según la norma europea EN 12101-6



El buen funcionamiento de los sistemas de presurización depende no solo del buen diseño de los mismos, sino también de la buena regulación que realice el sistema, por lo que es de vital importancia contar con elementos de regulación calibrados y de gran precisión, que permitan simultáneamente las dos situaciones presentes en caso de incendio, de forma rápida y estable.

Kit de sobrepresión de escaleras, formado por un cuadro de control (BOXSMART EC) y una unidad de impulsión de alta eficiencia con motores EC Technology (CJK/EC).

CM-SMART: Cuadro de mandos externo para bomberos

- El CM-SMART indica el estado del sistema y da la opción a los bomberos de activar o parar el sistema manualmente a través de su selector. Se recomienda instalar este cuadro en el acceso principal de la zona protegida por el sistema de presurización.
- Este equipo no va incluido en el KIT BOXSMART EC.
- El modelo BOXSMART EC es compatible con CM-SMART.



- Fácil instalación.
- Solución compacta y autónoma.
- Fácil puesta en marcha.
- Instalación segura y funcional.

Código de pedido

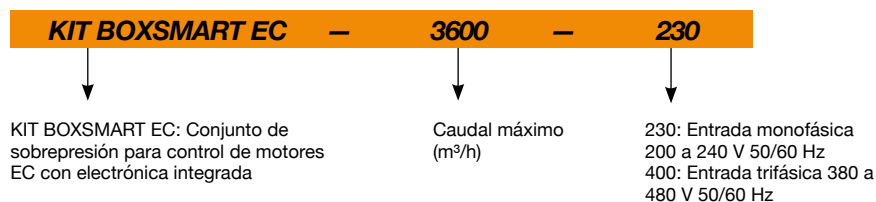

Características técnicas

Modelo	Potencia (kW)	Alimentación (V) (Hz)	Salida (V)	Caudal máximo (m ³ /h)	Unidad de impulsión
KIT BOXSMART EC-1900 - 230	0,2	200 a 240 V 50/60 Hz	230 V 50/60 Hz	1920	CJK/EC-310
KIT BOXSMART EC-3600 - 230	0,5	200 a 240 V 50/60 Hz	230 V 50/60 Hz	3640	CJK/EC-400
KIT BOXSMART EC-6500 - 400	1,1	380 a 480 V 50/60 Hz	400 V 50/60 Hz	6580	CJK/EC-500

* La potencia de salida se reduce un 20% cuando los equipos trabajan en el rango inferior de tensión de alimentación. Los mismos modelos, excepto los modelos FLAP, se pueden suministrar con KIT BOXSMART II para ventilador de reserva (se añade una segunda unidad de impulsión equivalente a la del KIT BOXSMART).

Dimensiones mm

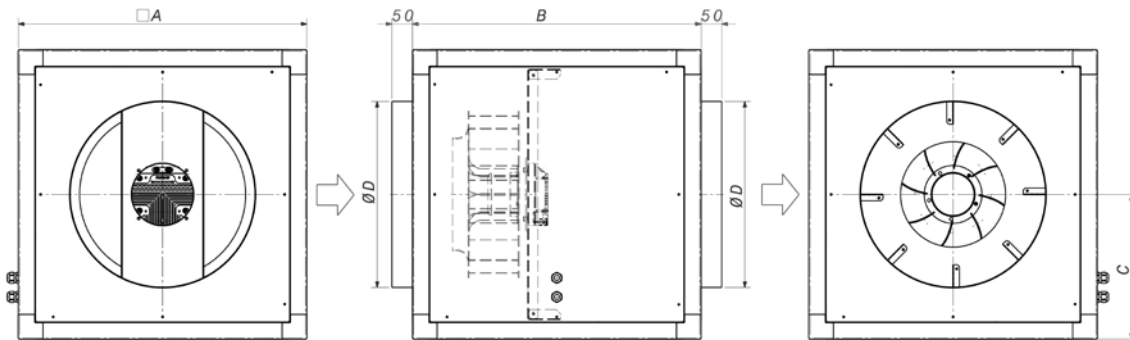

	A	B	C	ØD
CJK/EC-310	500	500	250	355
CJK/EC-400	700	700	350	450
CJK/EC-500	900	900	450	500

Ejemplo de aplicación

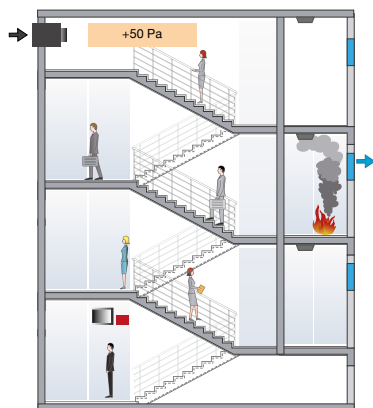

Método de control de humo por sobrepresión

Este sistema consiste en la presurización mediante inyección de aire en los habitáculos que son utilizados como vías de evacuación de personas en caso de incendio, tales como cajas de escalera, pasillos, corredores, elevadores, etc., sobre todo en edificios de altura con gran ocupación.

Este método está basado en el control del humo mediante la velocidad del aire y la barrera artificial que crea la sobrepresión del aire sobre el humo, para que éste no pueda entrar en las vías de evacuación.

BOXSMART EC

Cuadro de control para un ventilador motor EC



El cuadro de control BOXSMART EC incluye:

- Variador de frecuencia programado a 50 Pa y sonda de presión diferencial de gran precisión.
- Conexión externa para cuadro de mandos para uso exclusivo de bomberos.
- Magnetotérmico.
- Piloto indicador de estado: Operativo, Alarma, Activación por fuego y Marcha.
- Cuadro de mandos incorporado con selector TEST para mantenimiento y selector exclusivo para bomberos 0-AUTO-MANUAL.
- Protocolo de funcionamiento en modo seguro en caso de fallo de sonda de presión diferencial y rearme automático del sistema en caso de fallo.
- Conexión de señales de estado mediante contactos libres de potencial (FALLO, MARCHA y ACTIVACIÓN FUEGO) y conexión a sistemas BMS mediante Modbus RTU para la monitorización de los equipos.
- Memoria del último estado de activación para mayor seguridad reseteable desde

selector RESET en cuadro de mandos o mediante señal externa.

- Conexión externa para uso de ventilación diaria mediante accesorio SI-CALENDAR.
- Envoltorio metálica con protección IP66 y cerradura mediante llave de servicio.
- Habilitado para la gestión de motores asíncronos, IPM o RM.
- Listo para funcionar y desempeñar su función sobre el control de la presión de la instalación.
- Solo se debe conectar la línea de alimentación, el ventilador de impulsión y la señal de incendio.
- Diferentes rangos de tensión de entrada y potencia bajo demanda.

Opciones:

- BOXSMART EC: Cuadro de control para un ventilador motor EC.
- BOXSMART: Cuadro de control para un ventilador.
- BOXSMART II: Cuadro de control con ventilador de reserva.
- BOXSMART FLAP: Cuadro de control con ventilador de compuerta.

Código de pedido

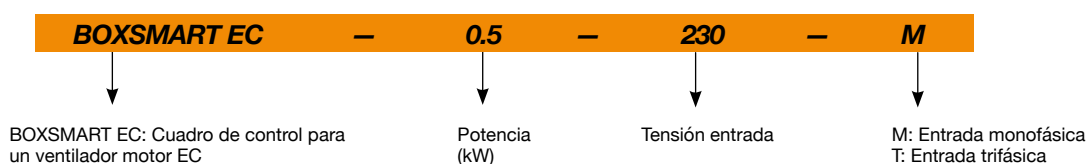

Características técnicas

Modelo	Potencia (kW)	Alimentación (V) (Hz)	Salida (V)	Intensidad máx. salida (A)	Tamaño	Medidas (largo x ancho x fondo)	Peso aprox. (Kg)
BOXSMART EC-0.5-230V 50/60HZ-M-M	0,5	200 a 240 V 50/60 Hz	230 V 50/60 Hz	1,5	1	300x400x200	10
BOXSMART EC-1.1-400V 50/60HZ-T-T	1,1	380 a 480 V 50/60 Hz	400 V 50/60 Hz	2,0	1	300x400x200	10

Conexiones

*Todas las conexiones se realizan en la parte superior del cuadro.

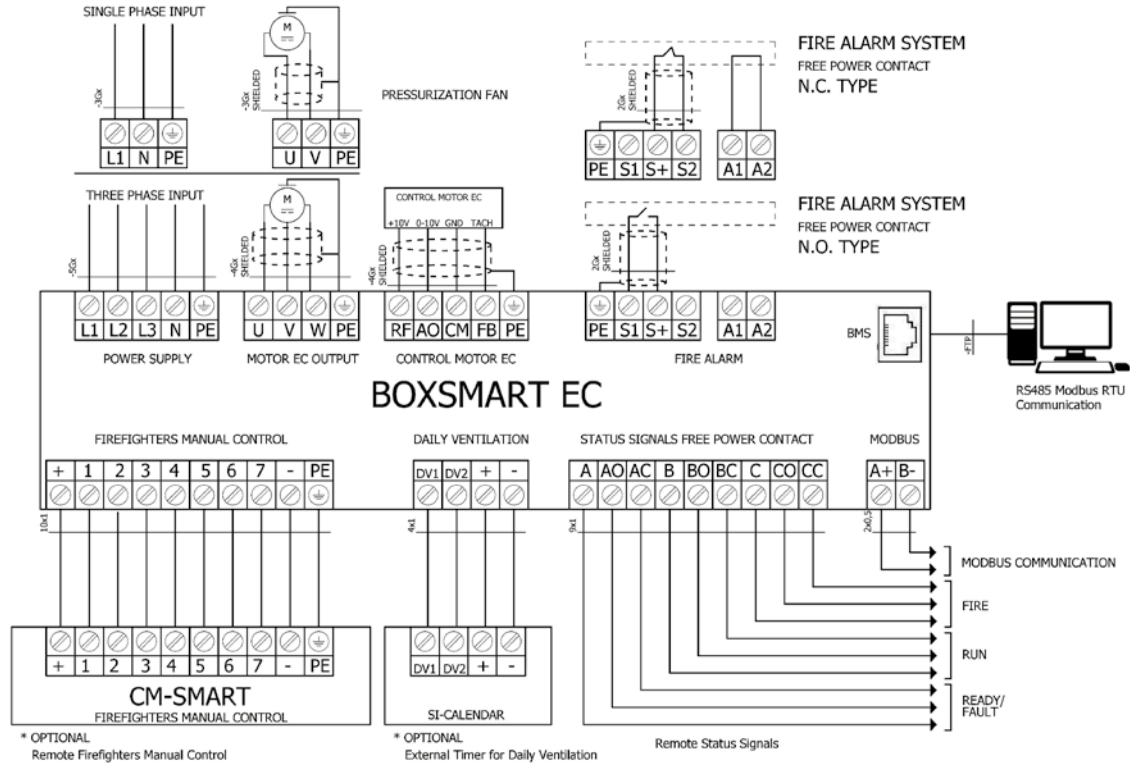

Accesorios



CM-SMART



SI-CALENDAR

KIT BOXSMART FLAP



Sistema de presurización de escaleras o vías de evacuación. Mantiene una presión diferencial de 50 Pa en una sola etapa, diseñados según la norma europea EN 12101-6



El buen funcionamiento de los sistemas de presurización depende no solo del buen diseño de los mismos, sino también de la buena regulación que realice el sistema, por lo que es de vital importancia contar con elementos de regulación calibrados y de gran precisión, que permitan simultanear las dos situaciones presentes en caso de incendio, de forma rápida y estable.

Kit de sobrepresión con ventilador de compuerta, formado por un cuadro de control (BOXSMART FLAP), que incorpora un sistema de control para ventiladores con compuerta (WALL o HATCH).

Accesorio opcional CM-SMART:

- Cuadro de mandos externo para bomberos.
- Indica el estado del sistema y da la opción a los bomberos de activar o parar el sistema manualmente a través de su selector. Se recomienda instalar este cuadro en el acceso principal de la zona protegida por el sistema de presurización.
- Este equipo no va incluido en el KIT BOXSMART FLAP.
- Los modelos BOXSMART FLAP son compatibles con CM-SMART FLAP.

Bajo demanda:

- Cuadros a medida para todas las potencias según necesidades del proyecto.



- Fácil instalación.
- Solución compacta y autónoma.
- Fácil puesta en marcha.
- Instalación segura y funcional.



Código de pedido

KIT BOXSMART FLAP – 21100 – 400

KIT BOXSMART FLAP: Conjunto de sobrepresión con ventilador de compuerta

Caudal máximo (m³/h)

400: Entrada trifásica 380 a 480 V 50/60 Hz

Características técnicas

Modelo	Potencia (kW)	Alimentación (V) (Hz)	Salida (V)	Caudal máximo (m ³ /h)	Unidad de impulsión
KIT BOXSMART FLAP-21100 - 400	1,5	380 a 480 V 50/60 Hz	400 V 50/60 Hz	21100	WALL/DUCT-71-4T IE3
KIT BOXSMART FLAP-25400 - 400	3,0	380 a 480 V 50/60 Hz	400 V 50/60 Hz	25400	HCT/HATCH-63-4T-4 IE3
KIT BOXSMART FLAP-41850 - 400	4,0	380 a 480 V 50/60 Hz	400 V 50/60 Hz	41850	WALL/DUCT-90-4T-5.5 IE3
KIT BOXSMART FLAP-52500 - 400	5,5	380 a 480 V 50/60 Hz	400 V 50/60 Hz	52500	HCT/HATCH-100-4T-7.5 IE3

* La potencia de salida se reduce un 20% cuando los equipos trabajan en el rango inferior de tensión de alimentación. Los mismos modelos, excepto los modelos FLAP, se pueden suministrar con KIT BOXSMART II para ventilador de reserva (se añade una segunda unidad de impulsión equivalente a la del KIT BOXSMART).

Dimensiones mm

HCT/HATCH

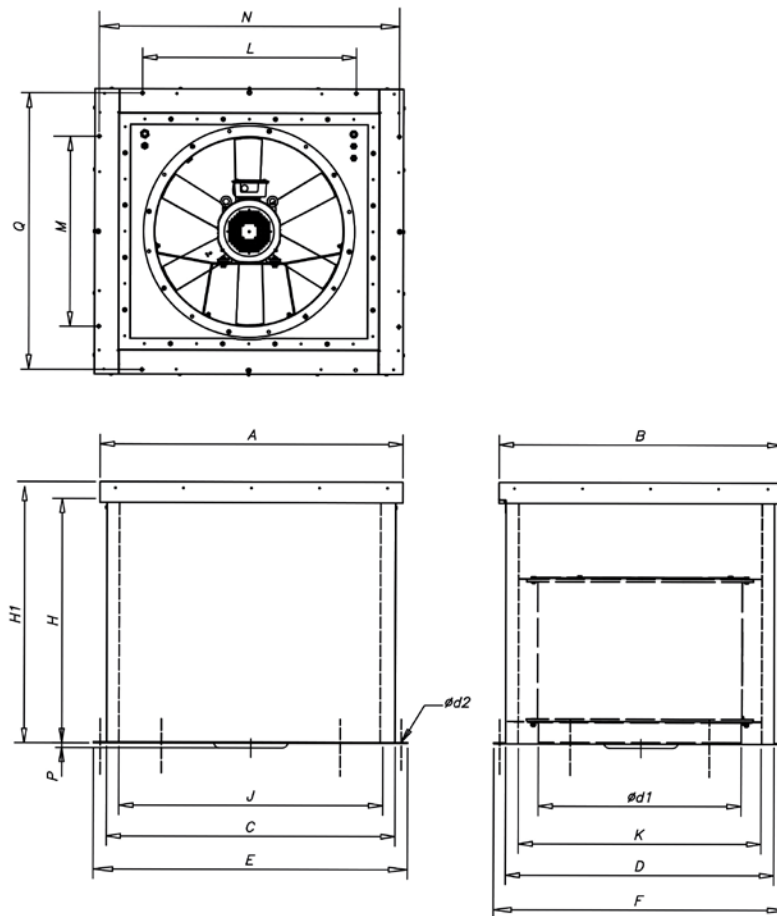

	A	B	C	D	$\varnothing d1$	E	F	H	H1	J	K	L	M	N	P	Q	$\varnothing d2$
HCT/HATCH-63	1300	1200	1220	1120	630	1300	1200	900	1000	1100	1000	900	800	1265	-	1165	13
HCT/HATCH-100	1500	1400	1420	1320	1000	1500	1400	900	1000	1300	1200	1100	1000	1465	-	1365	13

Dimensiones mm

WALL/DUCT

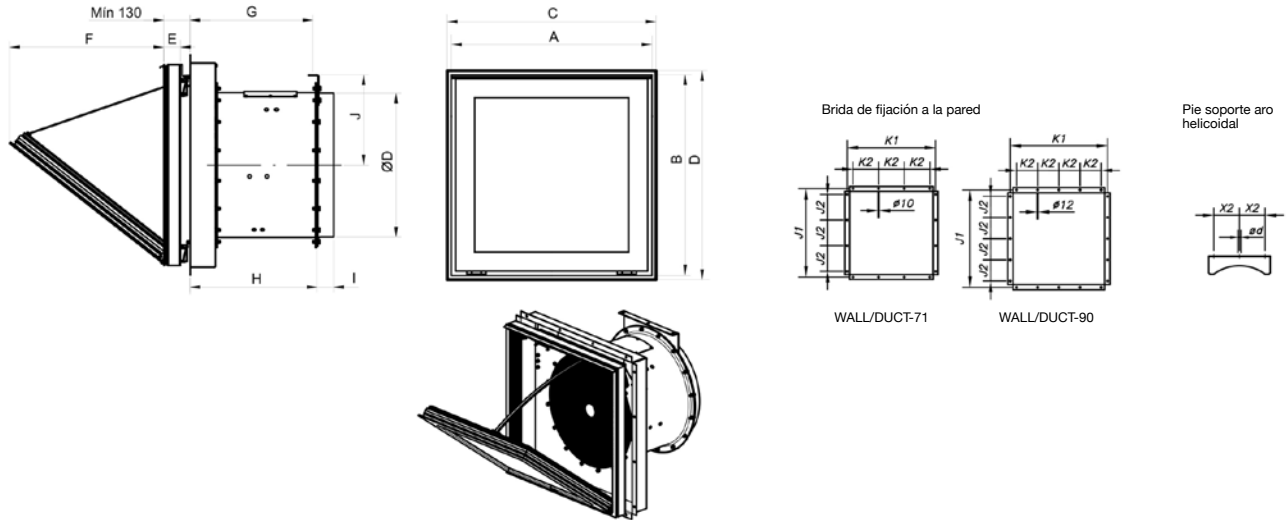

	A	B	C	Ød	D	ØD*	E	F	G	H	I	J	J1	J2	K1	K2	X2
WALL/DUCT-71	990	990	1000	13	1000	710	82	760	605	630	80	445	1050	300	1050	300	225
WALL/DUCT-90	1190	1190	1200	18	1200	900	82	790	605	630	100	550	1250	250	1250	250	280

* Diámetro nominal tubería recomendada.
(Cx) Dimensión nominal de apertura en panel.

Ejemplo de aplicación

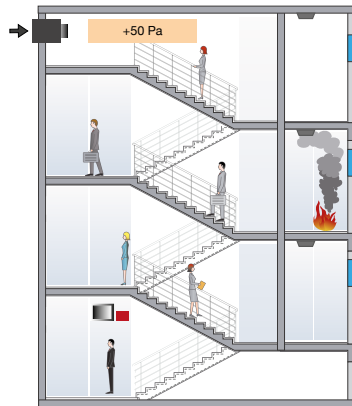

Método de control de humo por sobrepresión

Este sistema consiste en la presurización mediante inyección de aire en los habitáculos que son utilizados como vías de evacuación de personas en caso de incendio, tales como cajas de escalera, pasillos, corredores, elevadores, etc., sobre todo en edificios de altura con gran ocupación.

Este método está basado en el control del humo mediante la velocidad del aire y la barrera artificial que crea la sobrepresión del aire sobre el humo, para que éste no pueda entrar en las vías de evacuación.

BOXSMART FLAP

Cuadro de control con ventilador de compuerta



El cuadro de control BOXSMART FLAP incluye:

- Variador de frecuencia programado a 50 Pa y sonda de presión diferencial de gran precisión.
- Conexión externa para cuadro de mandos para uso exclusivo de bomberos.
- Magnetotérmico.
- Piloto indicador de estado: Operativo, Alarma, Activación por fuego y Marcha.
- Cuadro de mandos incorporado con selector TEST para mantenimiento y selector exclusivo para bomberos 0-AUTO-MANUAL.
- Protocolo de funcionamiento en modo seguro en caso de fallo de sonda de presión diferencial y rearme automático del sistema en caso de fallo.
- Conexión de señales de estado mediante contactos libres de potencial (FALLO, MARCHA y ACTIVACIÓN FUEGO) y conexión a sistemas BMS mediante Modbus RTU para la monitorización de los equipos.
- Memoria del último estado de activación para mayor seguridad reseteable desde

selector RESET en cuadro de mandos o mediante señal externa.

- Conexión externa para uso de ventilación diaria mediante accesorio SI-CALENDAR.
- Envolvente metálica con protección IP66 y cerradura mediante llave de servicio.
- Habilitado para la gestión de motores asíncronos, IPM o RM.
- Listo para funcionar y desempeñar su función sobre el control de la presión de la instalación.
- Solo se debe conectar la línea de alimentación, el ventilador de impulsión y la señal de incendio.
- Diferentes rangos de tensión de entrada y potencia bajo demanda.

Opciones:

- BOXSMART EC: Cuadro de control para un ventilador motor EC.
- BOXSMART: Cuadro de control para un ventilador.
- BOXSMART II: Cuadro de control con ventilador de reserva.
- BOXSMART FLAP: Cuadro de control con ventilador de compuerta.

Código de pedido

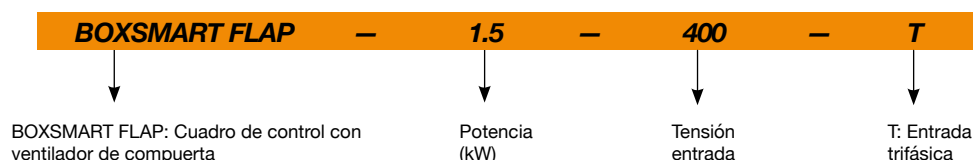

Características técnicas

Modelo	Potencia (kW)	Alimentación (V) (Hz)	Salida (V)	Intensidad máx. salida (A)	Tamaño	Medidas (largo x ancho x fondo)	Peso aprox. (Kg)
BOXSMART FLAP-1.5-400V 50/60Hz-T-T	1,50	380 a 480 V 50/60 Hz	400 V 50/60 Hz	4,1	2	400x500x250	18
BOXSMART FLAP-4-400V 50/60Hz-T-T	4,00	380 a 480 V 50/60 Hz	400 V 50/60 Hz	9,5	3	400x600x250	20
BOXSMART FLAP-5.5-400V 50/60Hz-T-T	5,50	380 a 480 V 50/60 Hz	400 V 50/60 Hz	14,0	4	500x700x250	28

Conexiones

*Todas las conexiones se realizan en la parte superior del cuadro.

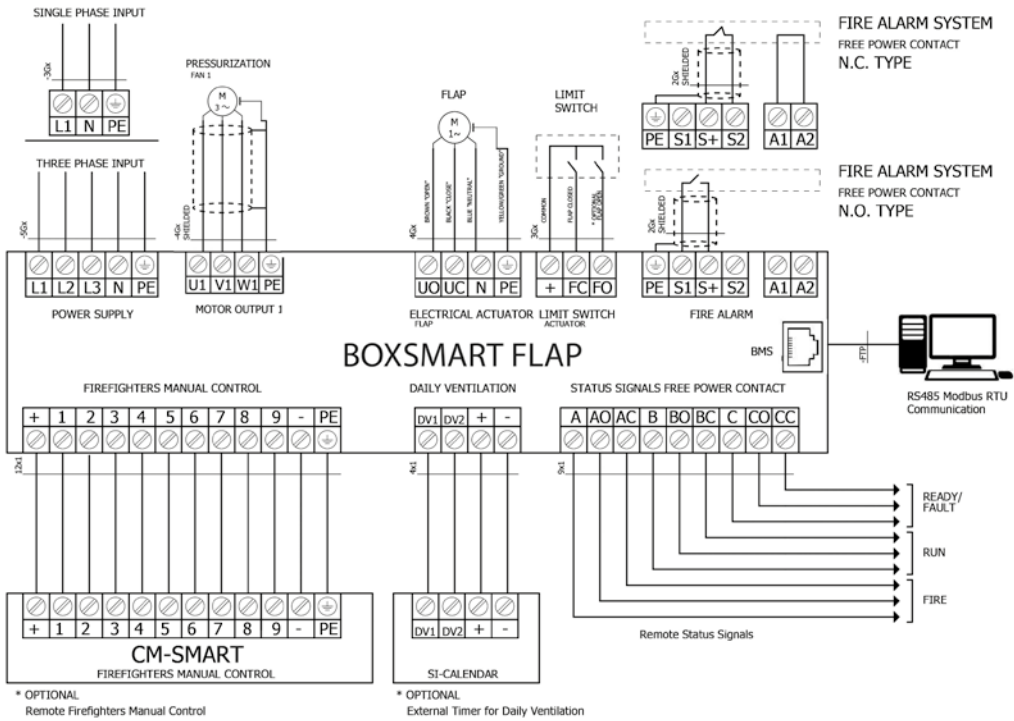

Accesorios



CM-SMART



SI-CALENDAR

KIT SOBREPRESIÓN



Sistema de presurización de escaleras o vías de evacuación. Mantiene una presión diferencial de 50 Pa en una sola etapa, diseñados según la norma europea EN 12101-6

KIT SOBREPRESIÓN DE ESCALERAS

Para equipos trifásicos



KIT SOBREPRESIÓN DE ESCALERAS

• Kit sobrepresión de escaleras, formado por un cuadro de control (BOXPRES KIT) y unidades de impulsión (CJHCH o CJBD), para la presurización de las escaleras y vías de evacuación. También disponible para equipos monofásicos.

KIT SOBREPRESIÓN CON VENTILADOR DE RESERVA

• Kit de sobrepresión con ventilador de reserva, formado por un cuadro de control (BOXPRES KIT II), que incorpora un sistema de conmutación automático para mantener la sobrepresión en caso de fallo del ventilador principal y unidades de impulsión de aire con ventilador de reserva.
• El cuadro de control BOXPRES, además de cumplir con las máximas exigencias, simplifica al máximo el trabajo del instalador.

KIT SOBREPRESIÓN DE ESCALERAS

Para equipos monofásicos



Incluye:

- Variador de frecuencia programado a 50 Pa.
- Sonda de presión diferencial.
- Magnetotérmico.
- Led de línea y fallo.
- Pulsador de chequeo.

BOXPRES, es un equipo con todas sus conexiones entre sí realizadas y probadas. Listo para funcionar y desempeñar su función sobre el control de la presión de la instalación. Posibilidad de chequeo de la instalación para evitar fallos. Sólo se debe conectar la línea de alimentación, el ventilador de impulsión y la señal de incendio.

Los cuadros para equipos monofásicos incluyen:

- Regulador de tensión programado a 50 Pa.
- Sonda de presión diferencial externa al equipo.

KIT SOBREPRESIÓN CON VENTILADOR DE RESERVA



- Fácil instalación.
- Solución compacta y autónoma.
- Mantenimiento preventivo.
- Fácil puesta en marcha.
- Instalación segura y funcional.



Código de pedido

KIT SOBREPRESIÓN

—

7100

KIT SOBREPRESIÓN: Conjunto de sobrepresión para escaleras
KIT SOBREPRESIÓN II: Conjunto de sobrepresión con ventilador de reserva

Caudal máximo (m³/h)

Características técnicas

Modelo	Alimentación	Salida	Unidad de impulsión	Caudal (m³/h)	Nivel sonoro dB (A)
KIT SOBREPRESION-1400-LED	230 V AC II	230 V AC II	NEOLINEO-250	1400	66
KIT SOBREPRESION-2200-LED	230 V AC II	230 V AC II	NEOLINEO-315	2200	69
KIT SOBREPRESION-2700-LED	230 V AC II	230 V AC II	CJBD-2525-6M 1/3	2700	61
KIT SOBREPRESION-7100-LED	230 V AC II	230 V AC III	CJHCH-45-4T-0.5	7100	55
KIT SOBREPRESION-7800-LED	230 V AC II	230 V AC III	CJBD-3333-6T-1 1/2	7800	55
KIT SOBREPRESION-12900-LED	230 V AC II	230 V AC III	CJHCH-56-4T-1	12900	60
KIT SOBREPRESION-17000-LED	230 V AC II	230 V AC III	CJHCH-63-4T-1.5	17000	61
KIT SOBREPRESION-7100-BOX	400 V AC III	400 V AC III	CJHCH-45-4T-0.5	7100	55
KIT SOBREPRESION-7800-BOX	400 V AC III	400 V AC III	CJBD-3333-6T-1 1/2	7800	55
KIT SOBREPRESION-12900-BOX	400 V AC III	400 V AC III	CJHCH-56-4T-1	12900	60
KIT SOBREPRESION-17000-BOX	400 V AC III	400 V AC III	CJHCH-63-4T-1.5	17000	61
KIT SOBREPRESION II-7800-BOX	400 V AC III	400 V AC III	CJBD/TWO-3333-6T-1.5	7800	75
KIT SOBREPRESION II-11400-BOX	400V AC III	400 V AC III	CJBD/TWO-15/15-6T-3	11400	75
KIT SOBREPRESION II-12900-BOX	400 V AC III	400 V AC III	CJHCH/DUPLEX-56-4T-1-H	12900	60
KIT SOBREPRESION II-17000-BOX	400 V AC III	400 V AC III	CJHCH/DUPLEX-63-4T-1.5-H	17000	61
SI-PRESIÓN TPDA					
SI-PRESIÓN TPDA c/DISPLAY					
BOXPRES KIT-3A 230Vac	230 V AC II	230 V AC II			
BOXPRES KIT-10A 230Vac	230 V AC II	230 V AC II			
BOXPRES KIT-0.37W 230Vac	230 V AC II	230 V AC II			
BOXPRES KIT-0.75KW 230Vac	230 V AC II	230 V AC III			
BOXPRES KIT-1.5KW 230Vac	230 V AC II	230 V AC III			
BOXPRES KIT-2.2KW 230Vac	230 V AC II	230 V AC II			
BOXPRES KIT-0.75KW 400Vac	400 V AC III	400 V AC III			
BOXPRES KIT-1.5KW 400Vac	400 V AC III	400 V AC III			
BOXPRES KIT-2.2KW 400Vac	400 V AC III	400 V AC III			
BOXPRES KIT II - 1.5KW 400Vac	400 V AC III	400 V AC III			
BOXPRES KIT II - 2.2KW 400Vac	400 V AC III	400 V AC III			

Dimensiones mm

CJBD

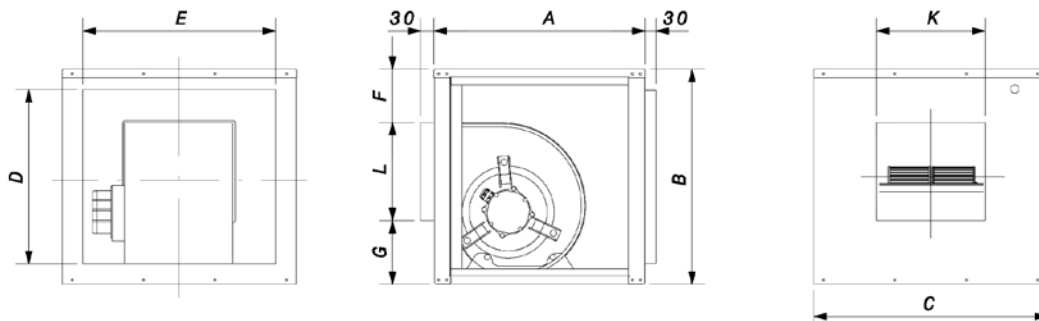

	Equivalencia Pulgadas	A	B	C	D	E	F	G	K	L
CJBD-2525	9/9	500	522	550	426	454	107	147	303	268
CJBD-3333	12/12	650	650	700	554	604	105	198	392	347

Dimensiones mm

CJHCH

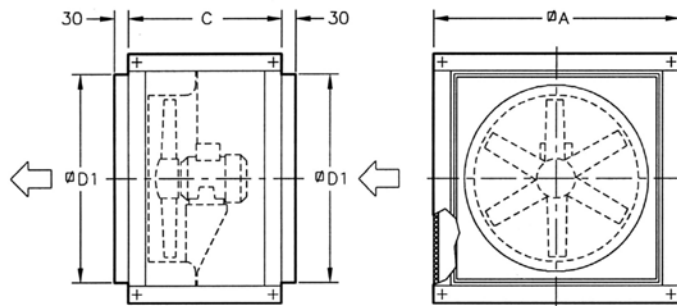

	A	C	D1
CJHCH-45	700	550	565
CJHCH-56/63	825	550	690

CJBD/TWO

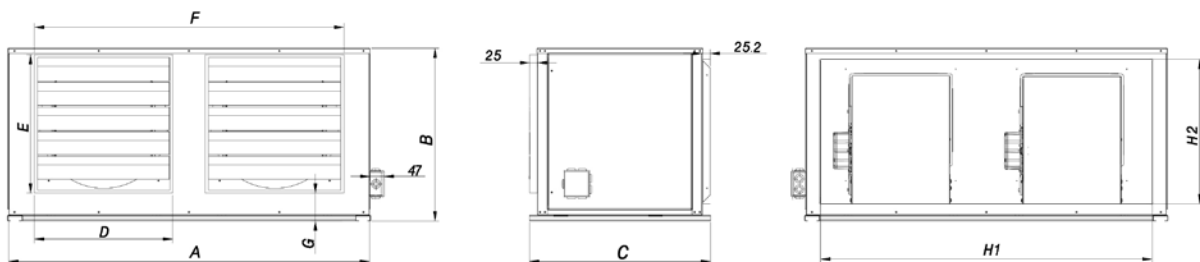

	A	B	C	D	E	F	G	H1	H2
CJBD/TWO-3333	1390	648,5	702,4	460	460	1149,3	156	1294,6	553,6
CJBD/TWO-15/15	1600	754	851,4	545	545	1342,6	186,5	1502,6	658,6

CJHCH/DUPLEX

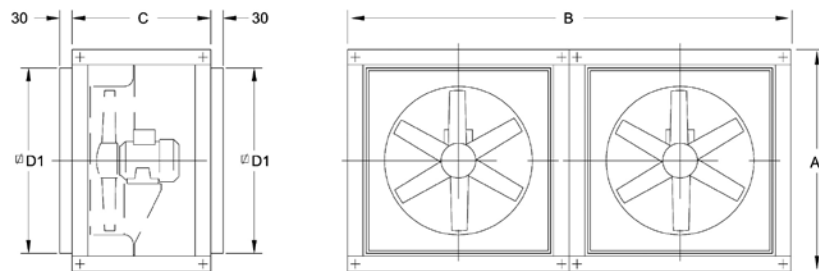

	A	B	C	D1
CJHCH/DUPLEX-56/63	825	1650	550	690

NEOLINEO

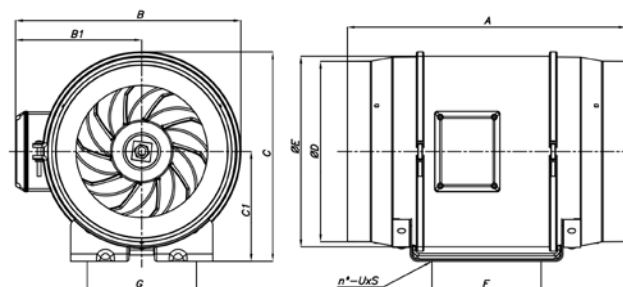

	A	B	B1	C	C1	ØD	ØE	F	G	n°	UxS
NEOLINEO-250/V	383	310	174	286	150	247	261	150	150	4	8x11
NEOLINEO-315/V	446	386	216	357	187	312	325	181	178	4	8x11

Características técnicas y dimensiones

BOXPRESS KIT SOBREPRESIÓN

Modelo	Potencia (kW)	Alimentación (V) (Hz)	Salida (V)	Intensidad máx. salida (A)	Tamaño	Medidas (largo x ancho x fondo)
BOXPRES KIT-3A 230Vac	-	230 V AC II	230 V AC II	3,0	-	255 x 170 x 140 mm
BOXPRES KIT-10A 230Vac	-	230 V AC II	230 V AC II	10,0	-	255 x 170 x 140 mm
BOXPRES KIT-0.37W 230Vac	0,37	230 V II / 50 Hz	230 V III / 50 Hz	2,3	1	270 x 270 x 170 mm
BOXPRES KIT-0,75kW 230Vac	0,75	230 V II / 50 Hz	230 V III / 50 Hz	4,3	1	270 x 270 x 170 mm
BOXPRES KIT-1.5kW 230Vac	1,50	230 V II / 50 Hz	230 V III / 50 Hz	7,0	1	270 x 270 x 170 mm
BOXPRES KIT-2.2KW 230Vac	2,20	230 V II / 50 Hz	230 V III / 50 Hz	10,5	2	360 x 360 x 205 mm
BOXPRES KIT-0.75KW 400Vac	0,75	400 V III / 50 Hz	400 V III / 50 Hz	2,2	1	270 x 270 x 170 mm
BOXPRES KIT-1.5KW 400Vac	1,50	400 V III / 50 Hz	400 V III / 50 Hz	4,1	1	270 x 270 x 170 mm
BOXPRES KIT-2.2KW 400Vac	2,20	400 V III / 50 Hz	400 V III / 50 Hz	5,8	2	360 x 360 x 205 mm

Prensaestopos de entrada cable a equipo

BOXPRES KIT-3A / KIT-10A



BOXPRES KIT Tamaño 1 y 2



BOXPRESS KIT SOBREPRESIÓN II

Para equipos con ventilador de reserva

Modelo	Potencia (kW)	Alimentación (V) (Hz)	Salida (V)	Intensidad máx. salida (A)	Tamaño	Medidas (largo x ancho x fondo)
BOXPRES KIT II-1.5KW 400Vac	1,5	400 V III / 50 Hz	400 V III / 50 Hz	4,1	1	270 x 270 x 170 mm
BOXPRES KIT II-2.2KW 400Vac	2,2	400 V III / 50 Hz	400 V III / 50 Hz	5,4	2	360 x 360 x 205 mm

Los dos motores nunca funcionan simultáneamente.

Prensaestopos de entrada cable a equipo

BOXPRES KIT Tamaño 1 y 2



Ejemplo de aplicación

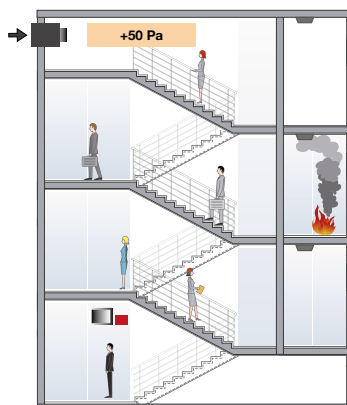

Método de control de humo por sobrepresión

Este sistema consiste en la presurización mediante inyección de aire en los habitáculos que son utilizados como vías de evacuación de personas en caso de incendio, tales como cajas de escalera, pasillos, corredores, elevadores, etc., sobre todo en edificios de altura con gran ocupación.

Este método está basado en el control del humo mediante la velocidad del aire y la barrera artificial que crea la sobrepresión del aire sobre el humo, para que éste no pueda entrar en las vías de evacuación.

KIT BOXPRES PLUS



Sistema de presurización de escaleras o vías de evacuación. Mantiene una presión diferencial de 50 Pa en una sola etapa, diseñados según la norma europea EN 12101-6



El buen funcionamiento de los sistemas de presurización depende no solo del buen diseño de los mismos, sino también de la buena regulación que realice el sistema, por lo que es de vital importancia contar con elementos de regulación calibrados y de gran precisión, que permitan simultanear las dos situaciones presentes en caso de incendio, de forma rápida y estable.

KIT BOXPRES PLUS

- Kit de sobrepresión de escaleras, formado por un cuadro de control (BOXPRES PLUS) y una unidad de impulsión (CJHCH o CJB), para la presurización de las escaleras y vías de evacuación.

KIT BOXPRES PLUS II

- Kit de sobrepresión con ventilador de reserva, formado por un cuadro

de control (BOXPRES PLUS II), que incorpora un sistema de conmutación automático para mantener la sobrepresión en caso de fallo del ventilador principal.

CM-SMART Cuadro de mandos externo para bomberos

- El CM-SMART indica el estado del sistema y da la opción a los bomberos de activar o parar el sistema manualmente a través de su selector. Se recomienda instalar este cuadro en el acceso principal de la zona protegida por el sistema de presurización.
- Este equipo no va incluido en el KIT BOXPRES PLUS.
- Los modelos BOXPRES PLUS y BOXPRES PLUS II son compatibles con CM-SMART.



- Fácil instalación.
- Solución compacta y autónoma.
- Fácil puesta en marcha.
- Instalación segura y funcional.

Código de pedido

KIT BOXPRES PLUS – 7100 – 230

KIT BOXPRES PLUS: Conjunto de sobrepresión
KIT BOXPRES PLUS II: Conjunto de sobrepresión con ventilador de reserva

Caudal máximo (m³/h)

230: Entrada monofásica 200 a 240 V 50/60 Hz
400: Entrada trifásica 380 a 480 V 50/60 Hz

Características técnicas

Modelo	Potencia (kW)	Alimentación (V) (Hz)	Salida (V)	Caudal máximo (m ³ /h)	Unidad de impulsión
KIT BOXPRES PLUS-2880 - 230	0,37	200 a 240 V 50/60 Hz	230 V 50/60 Hz	2880	CJBD-2828-4M 1/2
KIT BOXPRES PLUS-7100 - 230	0,37	200 a 240 V 50/60 Hz	230 V 50/60 Hz	7100	CJHCH-45-4T-0.5 IE3
KIT BOXPRES PLUS-7800 - 230	1,10	200 a 240 V 50/60 Hz	230 V 50/60 Hz	7800	CJBD-3333-6T 1 1/2
KIT BOXPRES PLUS-12900 - 230	0,75	200 a 240 V 50/60 Hz	230 V 50/60 Hz	12900	CJHCH-56-4T-1 IE3
KIT BOXPRES PLUS-17000 - 230	1,10	200 a 240 V 50/60 Hz	230 V 50/60 Hz	17000	CJHCH-63-4T-1.5 IE3
KIT BOXPRES PLUS-7800 - 400	1,10	380 a 480 V 50/60 Hz	400 V 50/60 Hz	7800	CJBD-3333-6T 1 1/2
KIT BOXPRES PLUS-12900 - 400	0,75	380 a 480 V 50/60 Hz	400 V 50/60 Hz	12900	CJHCH-56-4T-1 IE3
KIT BOXPRES PLUS-17000 - 400	1,10	380 a 480 V 50/60 Hz	400 V 50/60 Hz	17000	CJHCH-63-4T-1.5 IE3
KIT BOXPRES PLUS-21100 - 400	1,50	380 a 480 V 50/60 Hz	400 V 50/60 Hz	22100	CJHCH-71-4T-2 IE3

La potencia de salida se reduce un 20% cuando los equipos trabajan en el rango inferior de tensión de alimentación. Los mismos modelos se pueden suministrar con KIT BOXPRES PLUS II para ventilador de reserva (se añade una segunda unidad de impulsión equivalente a la del KIT BOXPRES PLUS).

Dimensiones mm

CJHCH

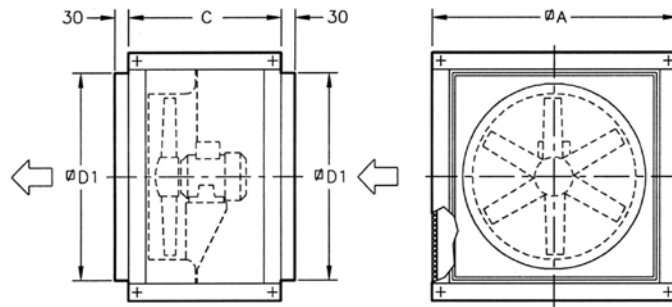

	ØA	C	ØD1
CJHCH-45	700	550	565
CJHCH-56/63	825	550	690
CJHCH-71	1000	650	850

CJBD

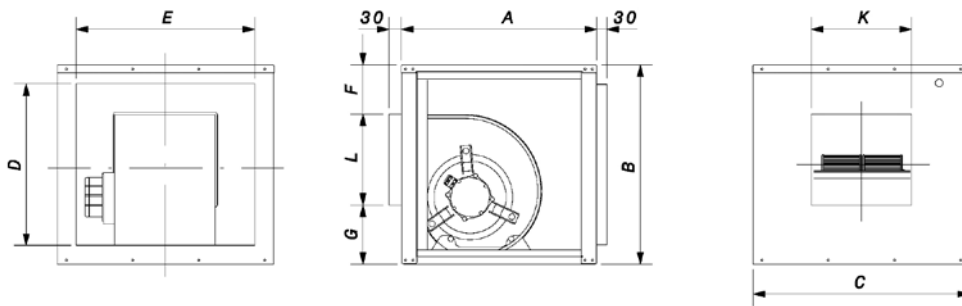

	Equivalencia Pulgadas	A	B	C	D	E	F	G	K	L
CJBD-2828	10/10	550	575	600	479	504	104	177	330	294
CJBD-3333	12/12	650	650	700	554	604	105	198	392	347

BOXPRES PLUS

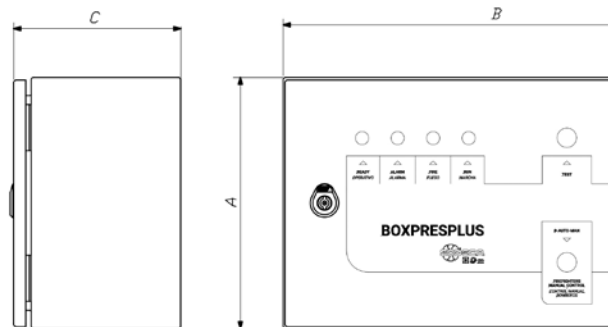

Tamaño	A	B	C
1	300	400	200
2	400	500	250
3	400	600	250
4	500	700	250

PRESSKIT



Equipos de presurización de vestíbulos de conformidad con el DM 30/11/1983 y diseñados según la norma europea EN 12101-6



Certificado: NR331151

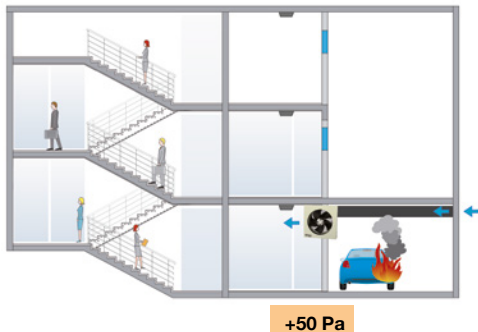

Los PRESSKIT son equipos formados por uno o más ventiladores. En caso de incendio se activan para ejercer una sobrepresión de 50 Pa en las zonas seguras y para evitar la entrada de humo en las vías de evacuación de personas.

Características comunes:

- Autoregulación de la presión en todo el vestíbulo.
- Ventiladores EC brushless 24 V DC con caudal máximo de 2100 m³/h.
- Mantener una sobrepresión de 50 Pa en vestíbulos.

CUADRO DE CONTROL

- Modelos S: Regulación simplificada de la unidad de ventilación mediante sonda de presión con regulador de señal PID incorporado.
- Modelos P: Control PLC con múltiples entradas, salidas, alarmas y regulación del ventilador mediante señal PID.
- Cuadro de alimentación con autonomía superior a 2 horas mediante baterías de 18Ah.
- Fácil conexión de los equipos.
- Rápida configuración y ajuste de todos los parámetros mediante pantalla LCD y teclado.
- Botón de activación MANUAL del sistema.
- Visualización a tiempo real de la presión de la zona segura y el estado del equipo.
- Cuadro de control del sistema mediante PLC de tamaño reducido y fácil instalación. Alimentación 230 V AC.
- Entrada digital detección de puerta abierta.

- Salidas digitales de indicación de alarma de incendio activada. Mediante testigo visual y acústico en modo intermitencia con tiempos configurables.
- Tiempos de retardo a la conexión configurables en caso de detección de alarma de incendio y puertas antincendios abiertas.
- Visualización de la presión en Pa a tiempo real. Indicación de estado del equipo STANDBY/ PRESSURIZING.
- Posibilidad de control de 2 ventiladores con un único panel y fuente de alimentación. (PRESSKIT TWIN).
- Cerradura con llave.

VENTILADOR PRESURIZACIÓN

- Ventilador mural para conductos de 310 mm de diámetro.
- Vida útil en trabajo continuo de más de 20.000 horas.
- Hélice de chapa de acero pintada.
- Reja de protección anticorrosivos.

SENSOR DE PRESIÓN CON PANTALLA (INCORPORADO EN CUADRO DE CONTROL)

- Sensor de presión diferencial preconfigurado de 0-100 Pa.
- Pantalla LCD.
- Sensor analógico calibrado de alta precisión.



Características cuadro de control

- Tensión total (V): 1x230
- Tensión salida 1 (V): 19.7-28 V DC
- Intensidad máx. salida 1 (A): 6
- Protección (IP): 44
- Peso aprox. (Kg): 30.5
- Intensidad total (A): 0.3
- Tensión salida 2 (V): 19.7-28 V DC
- Intensidad máx. salida 2 (A): 7
- Temperatura de trabajo (°C): -25 a +60

Código de pedido

PRESSKIT — **ONE** — **P**



PRESSKIT: Equipos de presurización de vestíbulos de conformidad con el DM 30/11/1983 y diseñados según la norma europea EN 12101-6



Formato del kit
ONE: 1 Ventilador
TWIN: 2 Ventiladores



Opciones de control
S: Regulación simple
P: Control con PLC

Características técnicas

Modelo	Caudal (m ³ /h)	Presión máxima (Pa)	Velocidad (r/min)	LpA irradiado 3 m dB(A)	Tensión total (V)	Intensidad total (A)	Potencia total (w)	Peso aprox. (Kg)	Protección (IP)	Temperatura de trabajo (°C)	Diámetro nominal conducto (mm)
PRESSKIT ONE	2100	180	1800	65	24 V DC	4.8	115	7	42	-25 a +60	310
PRESSKIT TWIN	4100	180	1800	68	24 V DC	9.6	230	14	42	-25 a +60	310

Dimensiones mm

VENTILADOR PRESURIZACIÓN

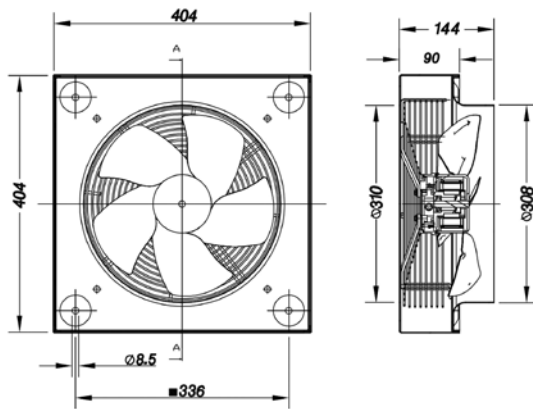

CUADRO DE CONTROL

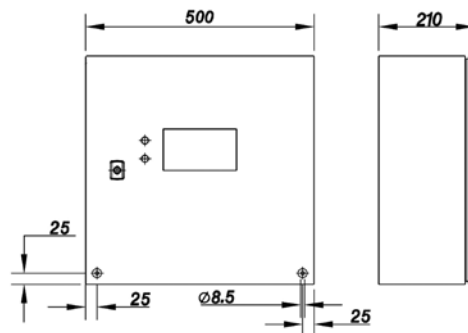

Características de los kits

Componente	PRESSKIT	
	ONE	TWIN
Regulación mediante sonda de presión	SI	SI
Regulación de varios ventiladores	-	SI*
Salidas relé para indicar que el equipo está activado	SI	SI
Entradas detectores de puertas	SI	SI

* PRESSKIT TWIN regula dos ventiladores simultáneamente con una única sonda de presión para vestíbulos/zonas presurizadas de tamaño grande. La regulación de cada ventilador no es independiente, utilizan la misma consigna de PID según la señal recibida de la sonda.

Configuraciones

Componente	PRESSKIT	PRESSKIT
	ONE	TWIN
VENTILADOR EC BRUSHLESS 24 VDC	1 unidad	2 unidades
CUADRO DE CONTROL	1 unidad	1 unidad
SENSOR PRESIÓN (INCORPORADO EN CUADRO DE CONTROL)	1 unidad	1 unidad

Accesorios



PULSADOR
ALARMA



COMPROBADOR
BATERÍAS

Comprobador tensión de salida de la fuente de alimentación y de las baterías mediante conector RJ45.

BOXPRES PLUS

Cuadro de control para un ventilador



El cuadro de control BOXPRES PLUS incluye:

- Variador de frecuencia programado a 50 Pa y sonda de presión diferencial de gran precisión.
- Conexión externa para cuadro de mandos para uso exclusivo de bomberos.
- Magnetotérmico.
- Piloto indicador de estado: Operativo, Alarma, Activación por fuego y Marcha.
- Cuadro de mandos incorporado con selector TEST para mantenimiento y selector exclusivo para bomberos 0-AUTO-MANUAL.
- Protocolo de funcionamiento en modo seguro en caso de fallo de sonda de presión diferencial y rearme automático del sistema en caso de fallo.
- Conexión de señales de estado mediante contactos libres de potencial

(FALLO, MARCHA y ACTIVACIÓN FUEGO) y conexión a sistemas BMS mediante Modbus RTU para la monitorización de los equipos.

- Mantenimiento de operatividad una vez activado por alarma de incendio, aun con interrupción de la señal de activación.
- Envolverte metálica con protección IP66 y cerradura mediante llave de servicio.
- Habilitado para la gestión de motores asíncronos, IPM o RM.
- Listo para funcionar y desempeñar su función sobre el control de la presión de la instalación.
- Solo se debe conectar la línea de alimentación, el ventilador de impulsión y la señal de incendio.
- Diferentes rangos de tensión de entrada y potencia bajo demanda.

Código de pedido



Características técnicas y dimensiones

BOXPRES PLUS							
Modelo	Potencia	Alimentación	Salida	Intensidad máx. salida	Tamaño	Medidas	Peso aprox.
	(kW)	(V) (Hz)	(V)	(A)		(largo x ancho x fondo)	(Kg)
BOXPRES PLUS-0.37-230V 50/60Hz-M-T	0,37	200 a 240 V 50/60 Hz	230 V 50/60 Hz	2,3	1	300x400x200	11
BOXPRES PLUS-0.75-230V 50/60Hz-M-T	0,75	200 a 240 V 50/60 Hz	230 V 50/60 Hz	4,3	1	300x400x200	11
BOXPRES PLUS-1.5-230V 50/60Hz-M-T	1,50	200 a 240 V 50/60 Hz	230 V 50/60 Hz	7,0	1	300x400x200	11
BOXPRES PLUS-0.75-400V 50/60Hz-T-T	0,75	380 a 480 V 50/60 Hz	400 V 50/60 Hz	2,2	1	300x400x200	11
BOXPRES PLUS-1.5-400V 50/60Hz-T-T	1,50	380 a 480 V 50/60 Hz	400 V 50/60 Hz	4,1	1	300x400x200	11
BOXPRES PLUS-2.2-400V 50/60Hz-T-T	2,20	380 a 480 V 50/60 Hz	400 V 50/60 Hz	5,8	2	400x500x250	18
BOXPRES PLUS-4-400V 50/60Hz-T-T	4,00	380 a 480 V 50/60 Hz	400 V 50/60 Hz	9,5	2	400x500x250	18
BOXPRES PLUS-5.5-400V 50/60Hz-T-T	5,50	380 a 480 V 50/60 Hz	400 V 50/60 Hz	14,0	3	400x600x250	21
BOXPRES PLUS-7.5-400V 50/60Hz-T-T	7,50	380 a 480 V 50/60 Hz	400 V 50/60 Hz	18,0	3	400x600x250	21
BOXPRES PLUS-11-400V 50/60Hz-T-T	11,00	380 a 480 V 50/60 Hz	400 V 50/60 Hz	24,0	3	400x600x250	21

Características técnicas y dimensiones

BOXPRES PLUS II

Para sistemas con ventilador de reserva. Los ventiladores nunca funcionan simultáneamente.

Modelo	Potencia (kW)	Alimentación (V) (Hz)	Salida (V)	Intensidad máx. salida (A)	Tamaño	Medidas (largo x ancho x fondo)	Peso aprox. (Kg)
BOXPRES PLUS II-0.37-230V 50/60Hz-M-T	0,37	200 a 240 V 50/60 Hz	230 V 50/60 Hz	2,3	2	400x500x250	18
BOXPRES PLUS II-0.75-230V 50/60Hz-M-T	0,75	200 a 240 V 50/60 Hz	230 V 50/60 Hz	4,3	2	400x500x250	18
BOXPRES PLUS II-1.5-230V 50/60Hz-M-T	1,50	200 a 240 V 50/60 Hz	230 V 50/60 Hz	7,0	2	400x500x250	18
BOXPRES PLUS II-0.75-400V 50/60Hz-T-T	0,75	380 a 480 V 50/60 Hz	400 V 50/60 Hz	2,2	2	400x500x250	18
BOXPRES PLUS II-1.5-400V 50/60Hz-T-T	1,50	380 a 480 V 50/60 Hz	400 V 50/60 Hz	4,1	2	400x500x250	18
BOXPRES PLUS II-2.2-400V 50/60Hz-T-T	2,20	380 a 480 V 50/60 Hz	400 V 50/60 Hz	5,8	3	400x600x250	20
BOXPRES PLUS II-4-400V 50/60Hz-T-T	4,00	380 a 480 V 50/60 Hz	400 V 50/60 Hz	9,5	3	400x600x250	20
BOXPRES PLUS II-5.5-400V 50/60Hz-T-T	5,50	380 a 480 V 50/60 Hz	400 V 50/60 Hz	14,0	4	500x700x250	28
BOXPRES PLUS II-7.5-400V 50/60Hz-T-T	7,50	380 a 480 V 50/60 Hz	400 V 50/60 Hz	18,0	4	500x700x250	28
BOXPRES PLUS II-11-400V 50/60Hz-T-T	11,00	380 a 480 V 50/60 Hz	400 V 50/60 Hz	24,0	4	500x700x250	28

Conexiones

*Todas las conexiones se realizan en la parte superior del cuadro.

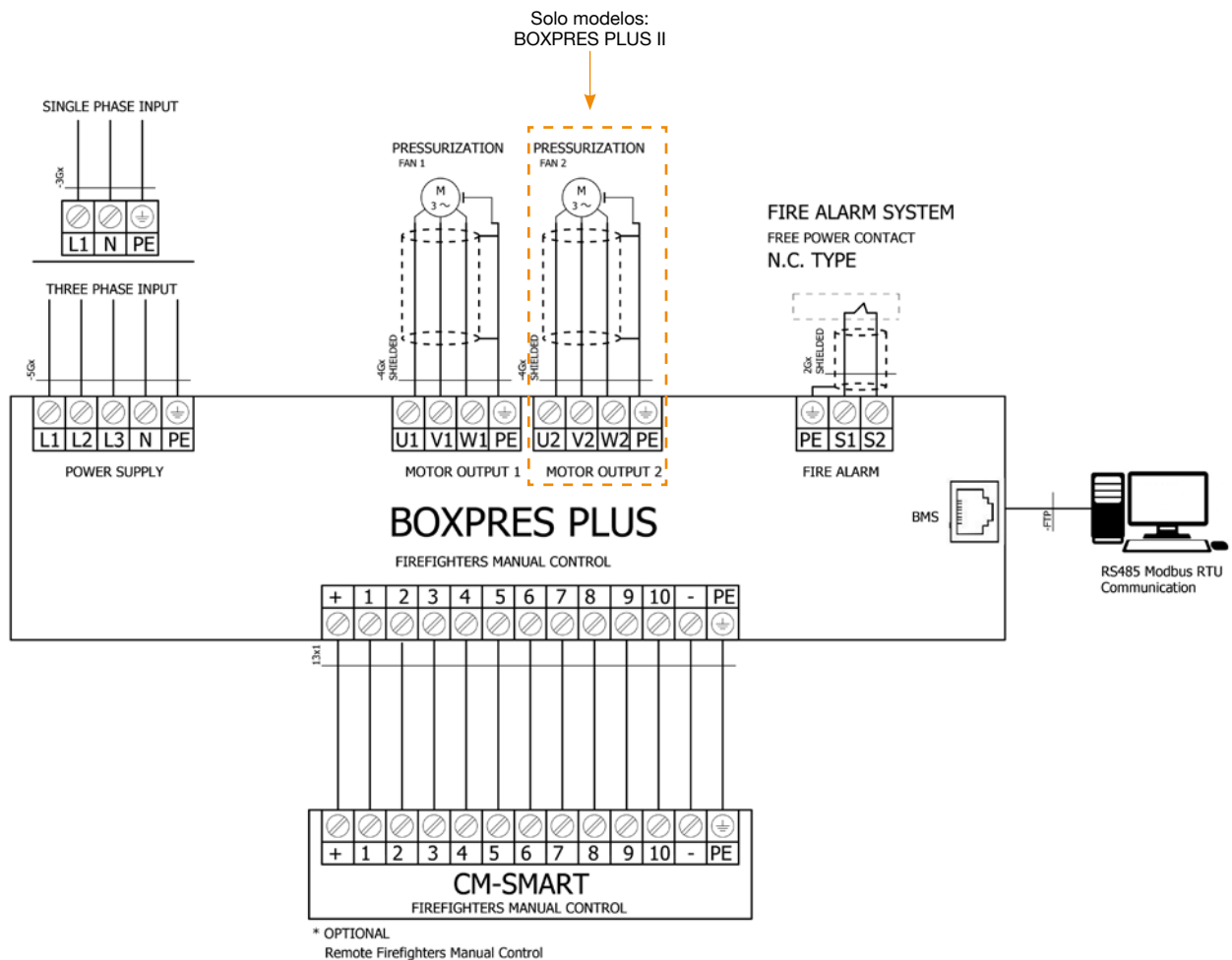

Dimensiones mm

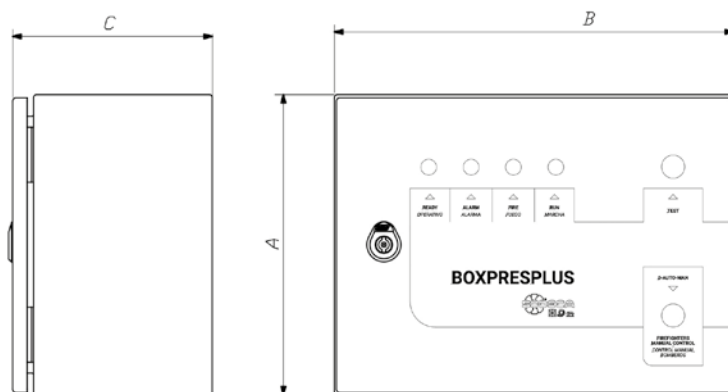

Tamaño	A	B	C
1	300	400	200
2	400	500	250
3	400	600	250
4	500	700	250

Ejemplo de aplicación

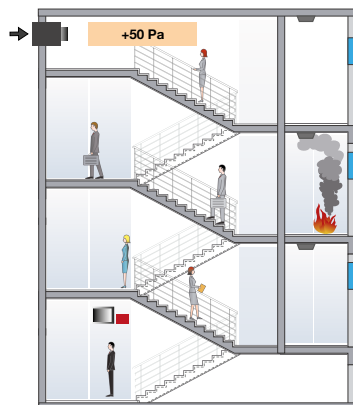

Método de control de humo por sobrepresión

Este sistema consiste en la presurización mediante inyección de aire en los habitáculos que son utilizados como vías de evacuación de personas en caso de incendio, tales como cajas de escalera, pasillos, corredores, elevadores, etc., sobre todo en edificios de altura con gran ocupación.

Este método está basado en el control del humo mediante la velocidad del aire y la barrera artificial que crea la sobrepresión del aire sobre el humo, para que éste no pueda entrar en las vías de evacuación.

Accesorios



CM-SMART

BOXPARK

Cuadros de control para sistemas de ventilación de aparcamientos con triple propósito: ventilación diaria, control de la concentración de CO y extracción de humo en caso de incendio



Cuadros de control en envoltorio metálica con todos los elementos necesarios para la gestión y control de los ventiladores de sistemas de ventilación de aparcamientos, ya estén basados en redes de conductos o en ventiladores de impulsos, para el control de los niveles de concentración de CO y la extracción de humo en caso de incendio. Cuadros a medida para todas las potencias y número de ventiladores según necesidades del proyecto.

BOXPARK BASIC:

- Cuadro de control para extracción de humo en caso de incendio y control de CO en aparcamientos para zona única, con modo de ventilación diaria mediante programador horario incluido.

BOXPARK ADVANCED:

- Cuadro de control para extracción de humo en caso de incendio y control de CO en aparcamientos para zona única o múltiples zonas, con modo de ventilación diaria mediante programador horario incluido, con posibilidad de gestionar compuertas motorizadas y de incorporar cuadro remoto para bomberos.

BOXPARK ADVANCED PLC:

- Cuadro de control para extracción de humo en caso de incendio y control de CO en aparcamientos para zona única o múltiples zonas, con modo de ventilación diaria mediante programador horario incluido, con posibilidad de gestionar compuertas motorizadas y de incorporar cuadro remoto para bomberos. Incluye PLC con algoritmo para gestión de secuencia de activación de los sistemas de ventilación, ya sea por redes de conductos o por impulsos (tipo Jet fan), en caso de incendio, con comunicaciones MODBUS y WEB SERVER incorporados. Toda la lógica del sistema se puede adaptar al proyecto bajo demanda.

Características genéricas armario BOPARK bajo demanda:

- Alimentación: 400 V AC trifásica más neutro y conductor de tierra.
- Envoltorio metálica, según dimensiones del equipo tipo mural o tipo autoportante con zócalo.
- Interruptor seccionador de corte en carga dimensionado a la potencia máxima del sistema.
- Ventilación del armario eléctrico natural o forzada, con termostato para activación/desactivación y protección magnetotérmica.
- Iluminación interior del armario (a partir de 1600 mm de altura).
- Voltaje auxiliar para maniobra a 24 V DC mediante fuente de alimentación y protecciones.
- Base SCHUKO en el interior del cuadro (protegido).
- Detector de desequilibrio y pérdida de fase.
- Protección de sobrecarga y cortocircuito por grupo.
- Según los accionamientos el equipo incorpora las siguientes protecciones:
 - Arranque mediante convertidor de frecuencia (VSD): Magnetotérmico individual entrada.
 - Arranque mediante contactor de una velocidad (S1): Magnetotérmico individual por grupo, interruptor protector de motor individualizado.
 - Arranque mediante contactor de doble velocidad (S2): Magnetotérmico individual por grupo, interruptor protector de motor individualizado para velocidad alta, interruptor protector de motor individualizado para velocidad lenta.
- Respaldo a la electrónica del sistema mediante SAI, en caso de fallo de la alimentación eléctrica.
- Microcontrolador con lógica programable (PLC).
- Comunicación con BMS, protocolo MODBUS TCP.
- WEB SERVER integrado para programación.
- Interruptor horario diario con reserva de batería, para activación de ventilación diaria por zona.
- Entrada de conexión con centralita de monóxido, tres niveles de activación de CO, nivel bajo, nivel alto y nivel de alarma. Contactos de activación libre de potencial NO.
- Entrada de conexión con central de detección de incendios, mediante contacto de activación libre de potencial NO o NC (seleccionable). Memoria del último estado de funcionamiento y señal de activación de incendio reseteable, mediante selector de llave en la parte frontal del armario.
- Selectores de 0-AUTO-MANUAL por grupo.
- Pilotos de estado en armario por zona (Sistema OK, Fallo, Marcha, Activación CO y Activación Fuego).
- Señales de estado (Sistema OK, Fallo, Marcha, Activación CO y Activación Fuego).
- Protección general de línea magnetotérmica y diferencial.
- Protección diferencial por grupo y zona (Jet fans, extracción, aporte).
- Gobierno de ventiladores de 2 velocidades.
- Gobierno de ventiladores mediante variador.
- Gobierno de ventiladores reversibles.
- Filtros LC (recomendable con gobierno mediante variador de frecuencia (VSD) a partir de 50 m de cable apantallado y a partir de 100 m de cable no apantallado).
- Posibilidad de petición para varias zonas.
- Posibilidad de señal analógica de CO para funcionamiento proporcional.
- Mando remoto para bomberos que incorpora selector 0-AUTO-MANUAL, y pilotos de estado (Sistema OK, Fallo, Marcha y Activación Fuego).
- Pantalla táctil para supervisión y configuración.
- Gestión de compuertas motorizadas.
- Interconexión entre cuadros.

Comparativa entre modelos

Características	BOXPARK BASIC	BOXPARK ADVANCED	BOXPARK ADVANCED PLC
Secuencia de activación para incendio (retardo Jet fans)	NO	NO	SI
Comunicación con BMS, protocolo MODBUS TCP	NO	NO	SI
Microcontrolador con lógica programable (PLC)	NO	NO	SI
WEB SERVER integrado para programación	NO	NO	SI
Reloj horario para ventilación diaria por zona	NO	SI	SI
Reloj horario para ventilación diaria general	SI	NO	NO
Tarjeta de memoria de estado de señal de incendio, incluyendo selector de Reset de incendio	NO	SI	SI
3 niveles de CO	NO	NO	SI
2 niveles de CO	SI	SI	NO
Señal analógica de CO para funcionamiento proporcional	NO	NO	OPCIONAL
Selectores de 0-AUTO-MANUAL por grupo	NO	SI	SI
Señal de incendio seleccionable NO-NC	SI	SI	SI
Señales de estado (Sistema OK, Fallo, Marcha, Activación CO y Activación Fuego)	NO	SI	SI
Cuadro remoto para bomberos CM (tipo BOXSMART)	NO	OPCIONAL	OPCIONAL
Multizona	NO	SI	SI
Pilotos de estado (Sistema OK, Fallo, Marcha, Activación CO y Activación Fuego)	SI	SI	SI
Pilotos de estado por zona (Sistema OK, Fallo, Marcha, Activación CO y Activación Fuego)	NO	NO	SI
Interruptor seccionador de corte en carga	SI	SI	SI
Protección sobrecarga y cortocircuito por grupo	SI	SI	SI
Protección general de línea magnetotérmica y diferencial	NO	OPCIONAL	OPCIONAL
Protección diferencial por grupo y zona (Jet fans, extracción, aporte)	NO	OPCIONAL	OPCIONAL
Gobierno de ventiladores de 2 velocidades	OPCIONAL	OPCIONAL	OPCIONAL
Gobierno de ventiladores mediante variador	OPCIONAL	OPCIONAL	OPCIONAL
Detector de desequilibrio y pérdida de fase	NO	OPCIONAL	SI
SAI	NO	NO	SI
Iluminación interior del armario (a partir de 1600 mm de altura)	NO	NO	SI
Base SCHUKO en el interior del cuadro (protegido)	NO	NO	SI
Interconexión entre cuadros	NO	OPCIONAL	OPCIONAL
Ventilación del armario (en función de tamaño de cuadro y potencia)	SI	SI	SI
Filtros LC (recomendable a partir de 50 m cable apantallado, a partir de 100 m cable NO apantallado)	OPCIONAL	OPCIONAL	OPCIONAL
Reversibilidad	NO	NO	OPCIONAL
Pantalla táctil para supervisión y configuración	NO	NO	OPCIONAL
Gestión de compuertas motorizadas	NO	OPCIONAL	OPCIONAL

Ejemplos de instalación con BOXPARK

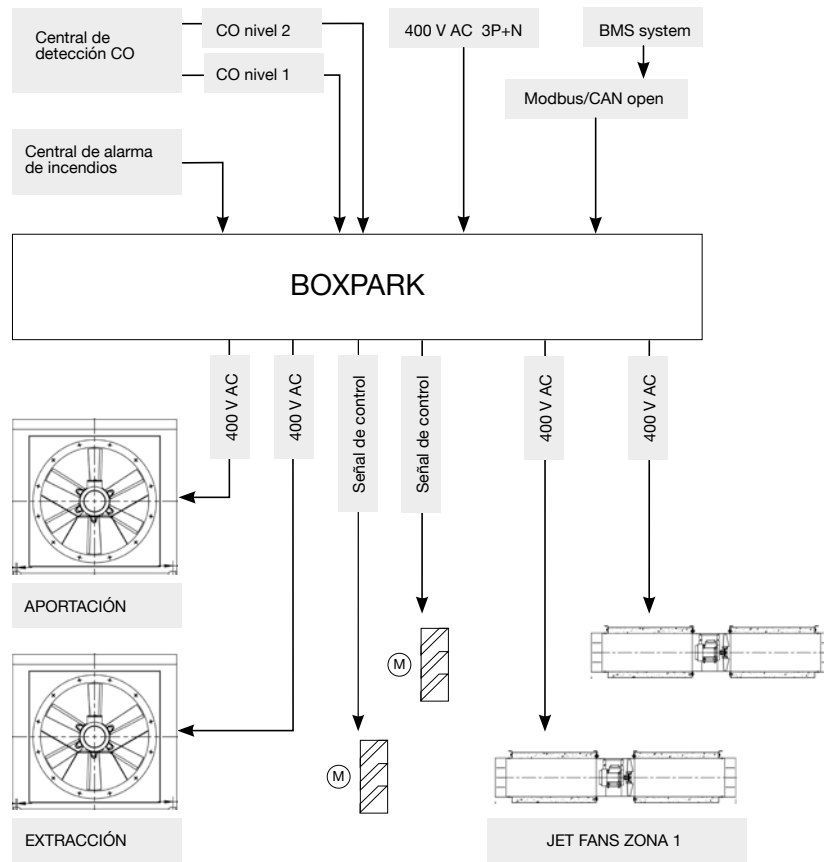

Accesorios



CM-SMART



CENTRAL CO

ACCESORIOS



INT

Interruptores de seguridad paro-marcha para cumplir la Norma UNE-EN 60204-1

Características:

- Interruptores para instalar al lado del ventilador y de esta forma poder cortar la corriente antes de manipular el ventilador.
- Protección IP65.
- Ventiladores monofásicos o trifásicos, utilizar interruptor de 3 polos (3CA).
- Ventiladores trifásicos de dos velocidades, utilizar interruptor de 6 polos (6CA).

Modelo	Intensidad (A)	(kW)	Entrada cables (mm)
INT-KG 20/3CA	25	7,5	29
INT-KG 41/3CA	40	15	37,5
INT-KG 64/3CA	63	22	37,5
INT-KG 80/3CA	80	30	37,5
INT-KG 100/3CA	100	37	37,5
INT-KG 20/6CA	25	7,5	29
INT-KG 41/6CA	40	15	37,5
INT-KG 64/6CA	63	22	37,5
INT-KG 80/6CA	80	30	37,5
INT-KG 100/6CA	100	37	37,5



INT/ATEX

Interruptor ATEX paro-marcha según directivas 2014/34/UE y 2014/35/UE II 2D Ex tb IIIC T XX °C Db II 3G Ex nR IIC T6 Gc IP66

Características:

- II 3G Ex nR IIC T6 Gc.
- II 2D Ex tb IIIC T XX °C Db IP66.
- Protección IP66.
- Construidos en termoplástico antiestático.
- Interruptores de 3 polos para motores trifásicos a una tensión de línea máxima de 500 V.

Modelo	Intensidad máxima (A)		Tensión (V)	Potencia máx. motor (kW) 400V	Entrada cables (mm)
	para zona 21 y 22 (Polvo)	para zona 2 (Gas)			
INT/ATEX 16/3CA	16	10	500	5,5	10÷14
INT/ATEX 25/3CA	25	20	500	7,5	12÷18
INT/ATEX 40/3CA	40	32	500	15,0	12÷18
INT/ATEX 63/3CA	63	50	500	22,0	16÷25



IAT

Interruptores de seguridad paro-marcha para 400 °C/2h para cumplir la Norma UNE-EN 60204-1

Características:

- Interruptores 400 °C/2h para instalar al lado del ventilador y de esta forma poder cortar la corriente antes de manipular el ventilador.
- Protección IP65 modelo 400 °C/2h.

Modelo	Intensidad (A)	Modelo	Intensidad (A)
IAT-400-20/3P	20	IAT-400-20/6P	20
IAT-400-32/3P	32	IAT-400-32/6P	32
IAT-400-63/3P	63	IAT-400-63/6P	63
IAT-400-125/3P	125	IAT-400-125/6P	125



C2V

Interruptor conmutador para motores de 2 velocidades

Características:

- Conmutador de 3 posiciones 1-0-2 para el accionamiento de motores de 2 velocidades conexión de Dahlander.
- Protección IP67.

Modelo	Intensidad (A)	(kW)	Entrada cables (mm)
C2V-CG10 A441	20	5,5	20

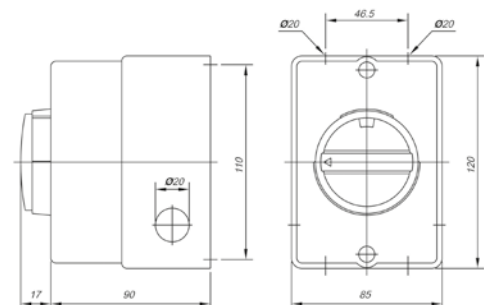

ACCESORIOS



CABLE BOX

Kit con cable eléctrico y caja de conexiones 400 °C/2h, para conexiones externas al motor, en instalaciones anti-incendios

Características:

- Cable eléctrico de 6 hilos + toma de tierra, con longitud de 1,5 m y terminales en cada extremo.
- Caja de bornes en fundición de aluminio.
- Regleta de conexiones en material cerámico.
- Kit certificado conjuntamente con la serie de extractores CJBBDT, con certificación N° 0370-CPR-0580.

Modelo	Tamaño máximo motor	Potencia máxima 400V (CV)		Aplica a diámetros												
		1 velocidad	2 velocidades	40	45	50	56	63	71	80	90	100	125	140	160	
CABLE BOX-1-400 (4Gx2.5)-450	100	4	N/A	X	X	X	X	X	X							
CABLE BOX-1-400 (7Gx2.5)-450	112	5,5	6	X	X	X	X	X	X							
CABLE BOX-2-400 (7Gx2.5)-550	160	12	12				X	X		X	X					
CABLE BOX-2-400 (7Gx2.5)-800	132	10	9									X				
CABLE BOX-3-400 (7Gx4)-800	160	20	20									X				
CABLE BOX-3-400 (7Gx6)-800	160	22	22					X					X	X	X	
CABLE BOX-4-400 (7Gx10)-800	280	75	40										X	X	X	
CABLE BOX-4-400 (13Gx10)-800	280	100	N/A										X			

RM



Reguladores electrónicos de velocidad para motores monofásicos

Regulación por tensión en referencias RM. Regulación por frecuencia en referencias RM/VSD1.

Características comunes:

- Convertidores para la variación de velocidad para ventiladores con motores monofásicos asíncronos.
- Alimentación del convertidor monofásico 230 V 50/60 Hz.
- Conmutador paro-marcha.
- Ajuste de velocidad mediante mando analógico.
- De acuerdo a la Directivas de Compatibilidad Electromagnética 2014/30/UE y Baja Tensión 2014/35/UE.

Características modelos RM:

- Ajuste de velocidad mínima.
- Con filtros EMC, según norma EN-55014.

Características modelos RM/VSD1:

- Fusible de protección de 16AF.
- Sistema dual de disipación de calor pasivo (radiador) y activo (ventilador de refrigeración).

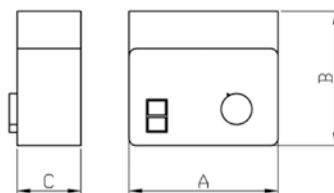

Modelo	A	B	C
RM-00	81	81	66
RM-01	81	81	66
RM-02	81	81	66
RM-1	80	145	80
RM-2	96	164	85
RM-3	96	164	85
RM/VSD1-3.5	200	180	100
RM/VSD1-8.0	200	225	100

Modelo	Tipo regulación	Tensión entrada	Tensión salida	Protección	Intensidad máxima (A)
RM-00	Tensión	230 V-50/60 Hz	230 V-50/60 Hz	IP44	0,5
RM-01	Tensión	230 V-50/60 Hz	230 V-50/60 Hz	IP44	1,0
RM-02	Tensión	230 V-50/60 Hz	230 V-50/60 Hz	IP44	2,0
RM-1	Tensión	230 V-50/60 Hz	230 V-50/60 Hz	IP54	3,0
RM-2	Tensión	230 V-50/60 Hz	230 V-50/60 Hz	IP54	5,0
RM-3	Tensión	230 V-50/60 Hz	230 V-50/60 Hz	IP54	10,0
RM/VSD1-3.5	Frecuencia	230 V-50/60 Hz	230 V-35...50 Hz	IP20	3,5
RM/VSD1-8.0	Frecuencia	230 V-50/60 Hz	230 V-35...50 Hz	IP20	8,0

ACCESORIOS



VSD3/A-RFT - VSD1/A-RFM

Variador electrónico de velocidad para motores AC

Características:

- Convertidores para la variación de velocidad mediante tensión y frecuencia, de ventiladores helicoidales y centrífugos con motores trifásicos asíncronos.
- Alimentación del convertidor:
 - Monofásico (VSD1/A-RFM): 200-240 V 50/60 Hz.
 - Trifásico (VSD3/A-RFT): 380-480 V 50/60 Hz.
- De acuerdo con la Directiva de Compatibilidad Electromagnética 2014/30/UE, la Directiva de Baja tensión 2014/35/UE y la Directiva de Seguridad de máquinas 2006/42/EC.
- Entrada paro/marcha para deshabilitar/habilitar el variador.
- Entrada 0-10 V para el control de velocidad.
- Conexión a bus ModBus RTU disponible.
- Modelo estándar con grado de protección IP20. Disponible también en versión IP66 hasta 10 CV. Para potencias superiores a 15 CV sólo disponible con grado de protección IP55.
- De acuerdo con las normas:
 - UNE EN 61800-3: Accionamientos eléctricos de potencia de velocidad variable. Norma de producto relativa a CEM incluyendo métodos de ensayos específicos.
 - UNE EN 61800-5-1: Accionamientos eléctricos de potencia de velocidad variable. Requisitos de seguridad. Eléctricos, térmicos y energéticos.
 - UNE EN 60204-1: Seguridad de las máquinas. Equipo eléctrico de las máquinas. Requisitos generales.

- UNE EN 55011: Límites y métodos de medida de las características relativas a las perturbaciones radioeléctricas de los aparatos industriales, científicos y médicos (ICM) que producen energía en radiofrecuencia.
- IEC 60529: Especificaciones para los grados de protección en los recintos.

En general, todos los ventiladores SODECA con motor trifásico en ejecución normal, son adecuados para trabajar alimentados con convertidor de frecuencia estático (según IEC 60034-17). No obstante algunos motores requieren medidas especiales. La máxima frecuencia o velocidad de funcionamiento, nunca deberá exceder la de diseño del ventilador. Las aplicaciones con par cuadrático tales como ventiladores y bombas, cuando varía la velocidad, la potencia absorbida es directamente proporcional al cubo de la velocidad de rotación: $Pa_2 = Pa_1 (n_2 / n_1)^3$.

El aislamiento de los motores acoplados a los ventiladores es suficiente para trabajar sin restricciones con convertidor de frecuencia hasta tensiones de hasta 500 V. La utilización de filtros senoidales a la salida del convertidor, contribuirán en el buen funcionamiento del motor, minimizando averías y aumentando la vida útil del mismo. Se recomienda que para motores de tamaño mayor que 225, éstos sean solicitados con devanados especiales para funcionar con convertidor de frecuencia.

La longitud de los cables de salida del convertidor al ventilador, influyen especialmente en las características de la tensión en bornes del motor. La definición de 'cables largos' dependerá del valor nominal y tipo de convertidor, siendo necesario consultar la documentación técnica del fabricante.

Para los motores Antideflagrantes Ex-d, estos deben solicitarse para ser accionados mediante convertidor de frecuencia. El fabricante del motor pedirá información de la aplicación mediante un cuestionario, para definir los parámetros de trabajo. Además dichos motores deberán llevar incorporadas sondas PTC.

Los motores de seguridad aumentada Ex-e, no pueden accionarse con convertidor de frecuencia (para ello sería necesario la certificación conjunta motor y convertidor).

VSD1/A-RFM		VSD1/A-RFM-0,5	VSD1/A-RFM-1	VSD1/A-RFM-2	VSD1/A-RFM-3
Potencia (CV)		0,50	1,00	2,00	3,00
Potencia (kW)		0,37	0,75	1,50	2,20
Intensidad máxima (A)		2,3	4,3	7,0	10,5
Entrada					
Tipo de entrada		Monofásica	Monofásica	Monofásica	Monofásica
Tensión (V)		200-240 V	200-240 V	200-240 V	200-240 V
Frecuencia (Hz)		50-60 Hz	50-60 Hz	50-60 Hz	50-60 Hz
Salida					
Tipo de salida		Trifásica	Trifásica	Trifásica	Trifásica
Tensión (V)		200-240 V	200-240 V	200-240 V	200-240 V
Frecuencia (Hz)		0-500 Hz	0-500 Hz	0-500 Hz	0-500 Hz
Grados de protección		Estándar: IP20. Bajo demanda: IP66			
Refrigeración		IP20: Forzada. IP66: Natural			

VSD3/A-RFT		VSD3/A-RFT-1	VSD3/A-RFT-2	VSD3/A-RFT-3	VSD3/A-RFT-5.5	VSD3/A-RFT-7.5	VSD3/A-RFT-10	VSD3/A-RFT-15	VSD3/A-RFT-20	VSD3/A-RFT-25	VSD3/A-RFT-30
Potencia (CV)		1,00	2,00	3,00	5,50	7,50	10,00	15,00	20,00	25,00	30,00
Potencia (kW)		0,75	1,50	2,20	4,00	5,50	7,50	11,00	15,00	18,50	22,00
Intensidad máxima (A)		2,2	4,1	5,8	9,5	14,0	18,0	24,0	30,0	39,0	46,0
Entrada											
Tipo de entrada		Trifásica	Trifásica	Trifásica	Trifásica	Trifásica	Trifásica	Trifásica	Trifásica	Trifásica	Trifásica
Tensión (V)		380-480 V	380-480 V	380-480 V	380-480 V	380-480 V	380-480 V	380-480 V	380-480 V	380-480 V	380-480 V
Frecuencia (Hz)		50-60 Hz	50-60 Hz	50-60 Hz	50-60 Hz	50-60 Hz	50-60 Hz	50-60 Hz	50-60 Hz	50-60 Hz	50-60 Hz
Salida											
Tipo de salida		Trifásica	Trifásica	Trifásica	Trifásica	Trifásica	Trifásica	Trifásica	Trifásica	Trifásica	Trifásica
Tensión (V)		380-480 V	380-480 V	380-480 V	380-480 V	380-480 V	380-480 V	380-480 V	380-480 V	380-480 V	380-480 V
Frecuencia (Hz)		0-500 Hz	0-500 Hz	0-500 Hz	0-500 Hz	0-500 Hz	0-500 Hz	0-500 Hz	0-500 Hz	0-500 Hz	0-500 Hz
Grados de protección		Estándar: IP20. Bajo demanda: IP66						IP20	IP20	IP20	IP20
Refrigeración		IP20 e IP55: Forzada. IP66: Natural									

ACCESORIOS



CENTRAL CO

Centrales de detección de monóxido, para el control de la ventilación en aparcamientos

Para cumplir el Real Decreto 2367/1985 y el Código Técnico de la Edificación. Las centrales de detección de monóxido de carbono, han sido diseñadas para su aplicación en aparcamientos de vehículos subterráneos, túneles u otros lugares donde pueden acumularse concentraciones peligrosas de CO.

El sistema consiste en la instalación de una central de 1 a 3 módulos de zonas con display indicador y cada módulo permite la conexión de hasta 32 detectores conectados con 2 hilos, con una distancia máxima hasta el último detector de 2 km. Los detectores pueden ser distribuidos a lo largo de 2.000 metros de longitud y cada detector cubre 200 m² de superficie como máximo, tal y como define la actual normativa.

A través de la tarjeta opcional FM-TC500 se puede controlar un regulador de velocidad serie RFM o RFT, con el fin de reducir el consumo energético y el nivel acústico de los extractores. Estos sistemas tienen como resultado un importante ahorro energético.

- Sistema certificado según norma UNE 23300/84.
- Certificación LOM 09MOGA3054.
- Central modular y ampliable.
- Hasta 19.000 m² de gestión.
- Versiones de 1, 2 y 3 módulos de zonas.
- Indicación de la concentración por zona.
- 2 salidas de relés de extracción por zona.
- 1 salida de relé de alarma por zona.
- Hasta 32 detectores por zona.
- Conexión de los detectores a 2 hilos.
- Modo de funcionamiento para bajo consumo.
- Opción de control por variador de velocidad para reducir consumo energético y nivel acústico.
- Opción de control remoto del sistema e integración con sistemas de análisis energético.

Centrales serie FMC-C-501/502/503:

- Para 1, 2 o 3 zonas según modelo.
- Tensión de alimentación 90-264 V AC.
- Potencia: 45 W.
- Módulo ampliación de zona FM-M-509.
- Conexión de la zona: 2 hilos.
- Distancia máxima de la línea de zona: 2 km, con cable 1,5 mm².
- N° detectores por zona: 32 detectores.

Detector CO serie FM-DP500/FM-D500:

- Detector CO de pared o techo según modelo.
- Tecnología: Célula electroquímica.
- Vida útil: 5 años.
- Resolución: 1 ppm.
- Tiempo de reacción: 10 segundos.
- Temperatura almacenamiento: -10 °C a +80 °C.
- Área de trabajo: 200 m² limitado por norma.
- Índice IP de FM-D500: IP20.
- Índice IP de FM-DP500: IP54.

Tarjeta de control por variador serie FM-TC500:

- Módulo con salidas PWM que permite controlar los motores de extracción mediante reguladores de velocidad (Ahorro energético).
- Módulo de comunicaciones para realizar acciones de tele mantenimiento y tele gestión.
- Protocolo abierto de comunicaciones para integración con otros sistemas.

Modelo	Aplicación
FMC-C-501	Central para 1 zona
FMC-C-502	Central para 2 zonas
FMC-C-503	Central para 3 zonas
FM-M-509	Módulo ampliación de zona
FM-DP500	Detector de CO de pared
FM-D500	Detector de CO de techo
FM-TC500	Tarjeta control por variador



AET

Cuadro eléctrico de arranque estrella/triángulo y protección de ventiladores trifásicos, con pulsadores de paro y marcha

Características:

- Paro y marcha mediante pulsador.
- Visualización de estado mediante pilotos luminosos.
- Incorpora relé térmico regulable para protección del motor.
- Totalmente cableado.
- Caja metálica para montaje en superficie, protección IP65.
- La intensidad de regulación del relé térmico debe ser el 50% de la intensidad nominal indicada en placa motor.

Para ventilador con motor trifásico 400V/690V
Alimentación 3x400V+N

Modelo	Intensidad regulación relé térmico (A)	Potencia motor 3x400/690V (kW)
AET-01-5.5/400	4-6, 3	4,0
AET-01-7.5/400	5-8	5,5
AET-01-10/400	7-10	7,5
AET-01-15/400	12-18	11,0
AET-01-20/400	12-18	15,0
AET-01-30/400	18-26	18,5/22,0
AET-01-40/400	28-40	30,0
AET-02-50/400	34-50	37,0
AET-02-60/400	45-65	45,0
AET-02-75/400	45-65	55,0

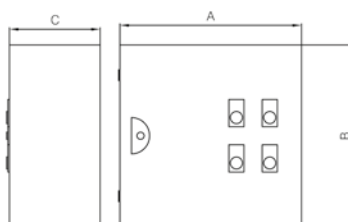

Modelo	A	B	C
AET-01	300	300	150
AET-02	400	400	200

ACCESORIOS



P-400

Persianas de sobrepresión, certificadas 400 °C/2h

Características:

- Se suministran montadas en la caja con su correspondiente adaptador.
- Homologación según norma EN 12101-3, con certificación n°: 0370-CPR-0312.
- Construcción marco en chapa de acero y lamas en chapa de aluminio.
- Puede ser utilizada para otras aplicaciones 400 °C/2h.

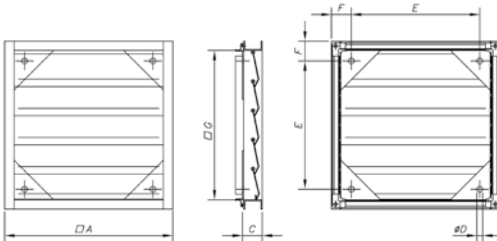

Modelo	G	A	C	ØD	E	F
P-400-56	565	615	51	6	455	80
P-400-63	690	760	72	6	600	80
P-400-80	850	920	72	6	740	90
P-400-100	1050	1120	72	6	940	90
P-400-125	1400	1486	102	6	1306	90
P-400-140	1500	1586	102	6	1366	110

Q= Caudal en m³/h, m³/s y cfm Pe= Presión estática en mmH₂O, Pa e inwg

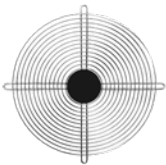
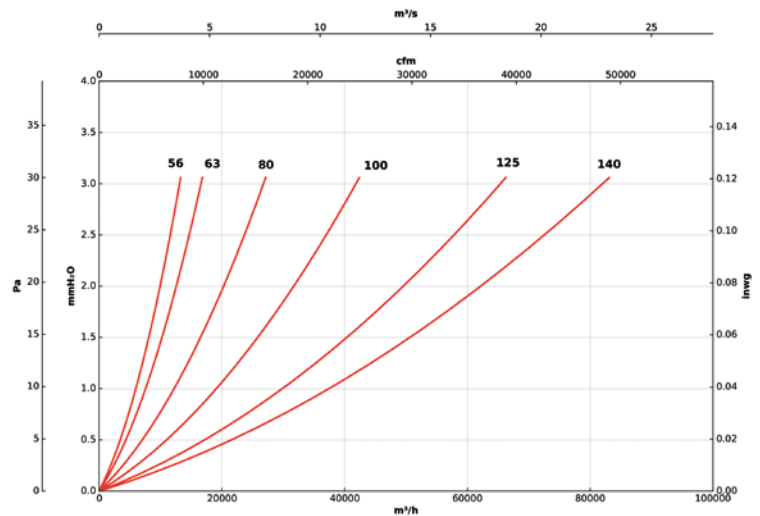

RT

Rejilla de protección para la aspiración o impulsión de ventiladores helicoidales tubulares

Características:

- Previene contra contactos con la hélice y posibles entradas de objetos, según norma UNE-EN ISO 12499.
- Construida con varilla electrosoldada.
- En la serie HEPT sólo puede ir en la impulsión.

Modelo	øA	øB	C	P	N	Nxα	Forma	Aplicable a THT
RT-25	280	259	10	11	-	4x90°	1	-
RT-31/B	320	301	10	11	-	4x90°	1	-
RT-31	355	322	10	11	-	4x90°	1	-
RT-35	395	364	10	11	-	4x90°	1	-
RT-40	450	426	12	11	-	4x90°	1	40
RT-45	500	468	12	11	-	4x90°	1	45
RT-50	560	528	12	11	-	4x90°	1	50
RT-56	620	572	-	11	12	4x90°	2	56
RT-63	690	655	-	11	12	4x90°	2	63
RT-71	770	732	-	11	12	4x90°	2	71
RT-80	860	820	-	11	12	4x90°	2	80
RT-90	970	930	-	11	12	4x90°	2	90
RT-100	1070	1018	-	11	12	4x90°	2	100
RT-125	1320	1260	-	11	18	10x36°	2	125
RT-125/CC	1320	1260	-	11	18	10x36°	2	125

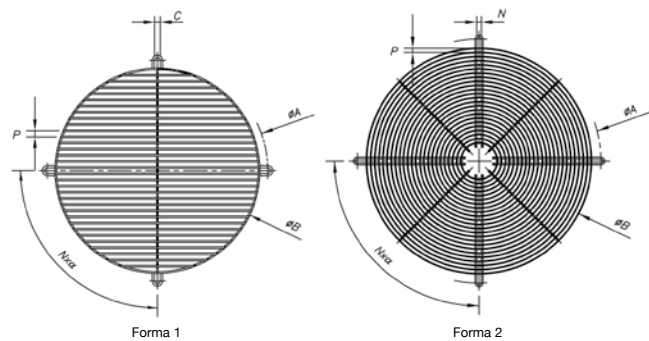

ACCESORIOS

RPA

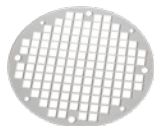

Rejilla de protección para la aspiración de ventiladores centrífugos

Características:

- Previene contra contactos con la turbina y posibles entradas de objetos, según norma UNE-EN ISO 12499.
- Construida en chapa de acero.

Modelo	Aplicable a	
	TCMP	TCR TCR/R
RPA-10	-	-
RPA-11	-	-
RPA-13	-	-
RPA-15	-	-
RPA-17	-	-
RPA-18	-	-
RPA-20	-	-
RPA-23	-	-
RPA-25	820	-
RPA-25/2	-	-
RPA-28	922	-
RPA-31	1025	-
RPA-32	-	-
RPA-35	1435/1640	-
RPA-38	1231	-

Modelo	Aplicable a	
	TCMP	TCR TCR/R
RPA-42	1435	-
RPA-44	-	-
RPA-47	2050	1240
RPA-48	-	-
RPA-52	1845	1445
RPA-55	2050	1650
RPA-60	2050	1650
RPA-65	-	-
RPA-66	-	1856
RPA-73	-	2063
RPA-74	-	-
RPA-81	-	2271
RPA-88	-	2380
RPA-90	-	-
RPA-100	-	-

R/THT



Rejilla de protección para la aspiración de ventiladores helicoidales de la serie THT

Características:

- Previene contra contactos con la hélice y posibles entradas de objetos, según norma UNE-EN ISO 12499.
- Construida con varilla electrosoldada.

Modelo	Aplicable a THT
R/THT-40	40
R/THT-45	45
R/THT-50	50
R/THT-56	56 (Tamaño motor 80/90)
R/THT-56-1	56 (Tamaño motor 100/112)
R/THT-63	63 (Tamaño motor 80/90)
R/THT-63-1	63 (Tamaño motor 100/112)
R/THT-63-2	63 (Tamaño motor 132)
R/THT-63-3	63 (Tamaño motor 160)
R/THT-71	71 (Tamaño motor 80/90)
R/THT-71-1	71 (Tamaño motor 100/112)
R/THT-80	80 (Tamaño motor 90)
R/THT-80-1	80 (Tamaño motor 100/112)
R/THT-80-2	80 (Tamaño motor 132)
R/THT-90-1	90 (Tamaño motor 100/112)
R/THT-90-2	90 (Tamaño motor 132)

Modelo	Aplicable a THT
R/THT-100	100 (Tamaño motor 112)
R/THT-100-1	100 (Tamaño motor 132)
R/THT-100-2	100 (Tamaño motor 160)
R/THT-125	125 (Tamaño motor 132)
R/THT-125-1	125 (Tamaño motor 160)
R/THT-125-2	125 (Tamaño motor 180)
R/THT-125-3	125 (Tamaño motor 200)
R/THT-125-4	125 (Tamaño motor 225/250)
R/THT-140	140 (Tamaño motor 132/180)
R/THT-140-1	140 (Tamaño motor 160/200)
R/THT-140-2	140 (Tamaño motor 225/250)
R/THT-160	160 (Tamaño motor 132/180)
R/THT-160-1	160 (Tamaño motor 160/200)
R/THT-160-2	160 (Tamaño motor 225/250)
R/THT-160-3	160 (Tamaño motor 280)

ACCESORIOS



BTUB

Brida de acoplamiento para ventiladores helicoidales

Ventilador:

- Se adapta a la boca de aspiración y de impulsión.
- Facilita la instalación al conducto.

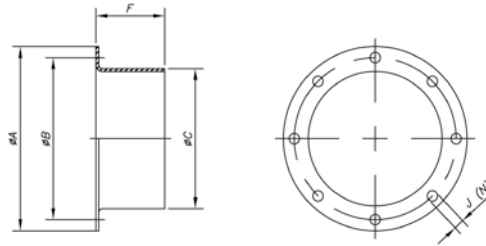

Modelo	øA	øB	øC	F	øJ	N
BTUB-250	310	280	250	80	10	4x90°
BTUB-280	350	320	280	80	10	4x90°
BTUB-315	380	355	315	80	10	8x45°
BTUB-355	430	395	355	80	11	8x45°
BTUB-400	480	450	400	80	12	8x45°
BTUB-450	530	500	450	80	12	8x45°
BTUB-500	590	560	500	80	12	12x30°
BTUB-560	650	620	560	80	12	12x30°
BTUB-630	720	690	630	80	12	12x30°
BTUB-710	800	770	710	80	12	16x22°30'
BTUB-800	890	860	800	100	13	16x22°30'
BTUB-900	1000	970	900	100	15	16x22°30'
BTUB-1000	1100	1070	1000	100	15	16x22°30'
BTUB-1250	1365	1320	1250	100	15	20x18°
BTUB-1400	1520	1470	1400	100	15	20x18°
BTUB-1600	1740	1680	1600	100	19	24x15°



B

Brida de acoplamiento para ventiladores centrífugos

Características:

- Se adapta a la boca de aspiración y de impulsión.
- Facilita la instalación al conducto.

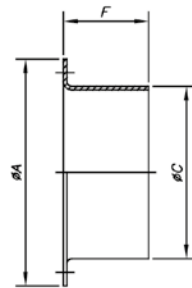

Modelo	ØA	ØC	F	Modelo	ØA	ØC	F
B-52-E	100	52	67	B-355/2	430	355	80
B-63	110	63	60	B-355/3	430	355	80
B-80	150	80	60	B-355/4	430	355	80
B-80-E	150	80	60	B-400/1	480	400	80
B-100	150	100	60	B-400/2	480	400	80
B-100-E	170	100	60	B-400/3	480	400	80
B-112	160	112	60	B-400/4	480	400	80
B-125	180	125	60	B-450/1	530	450	80
B-140	190	140	60	B-450/2	530	450	80
B-150	210	150	60	B-450/3	530	450	80
B-160	220	160	60	B-450/4	530	450	80
B-160/1	220	160	60	B-500/1	590	500	80
B-160/2	310	160	80	B-500/2	590	500	80
B-180	240	180	60	B-500/3	590	500	80
B-180/1	240	180	60	B-500/4	590	500	80
B-200	260	200	60	B-500/5	590	500	80
B-224	280	224	60	B-560/1	650	560	80
B-228	280	224	60	B-560/2	650	560	80
B-250/1	310	250	80	B-560/3	650	560	80
B-250/2	310	250	80	B-560/4	650	560	80
B-250/3	310	250	80	B-560/5	650	560	80
B-250/4	310	250	80	B-630/1	720	630	80
B-250/5	310	250	80	B-630/2	720	630	80
B-280/1	350	280	80	B-630/3	720	630	80
B-280/2	350	280	80	B-630/4	720	630	80
B-280/3	350	280	80	B-630/5	720	630	80
B-280/4	350	280	80	B-710/1	800	710	80
B-315/1	380	315	80	B-710/2	800	710	80
B-315/2	380	315	80	B-710/3	800	710	80
B-315/3	380	315	80	B-800	890	800	100
B-315/4	380	315	80	B-900/1	1000	900	100
B-355/1	430	355	80	B-1000/1	1100	1000	100

Aplicable a

Modelo	Aplicable a		
	CHT CVT	TCMP	TCR TCR/R
B-200	-	820	-
B-224	-	922	-
B-250/3	200/225	1025	-
B-280/2	-	1128	-
B-315/4	-	1231	-
B-355/3	250/315	1435	-
B-400/1	-	1640	-
B-400/2	-	-	1240
B-450/1	-	1845	-
B-450/2	-	-	1445
B-500/1	-	2050	-
B-500/2	-	-	1650
B-500/4	400/450	-	-
B-560/2	-	-	1856
B-630/2	-	-	2063
B-630/3	500	-	-
B-710/1	-	-	2271
B-710/2	560/630	-	-

ACCESORIOS



BD

Brida de acoplamiento doble para ventiladores centrífugos

Características:

- Se adapta a la boca de aspiración.
- Facilita la instalación al conducto con brida.

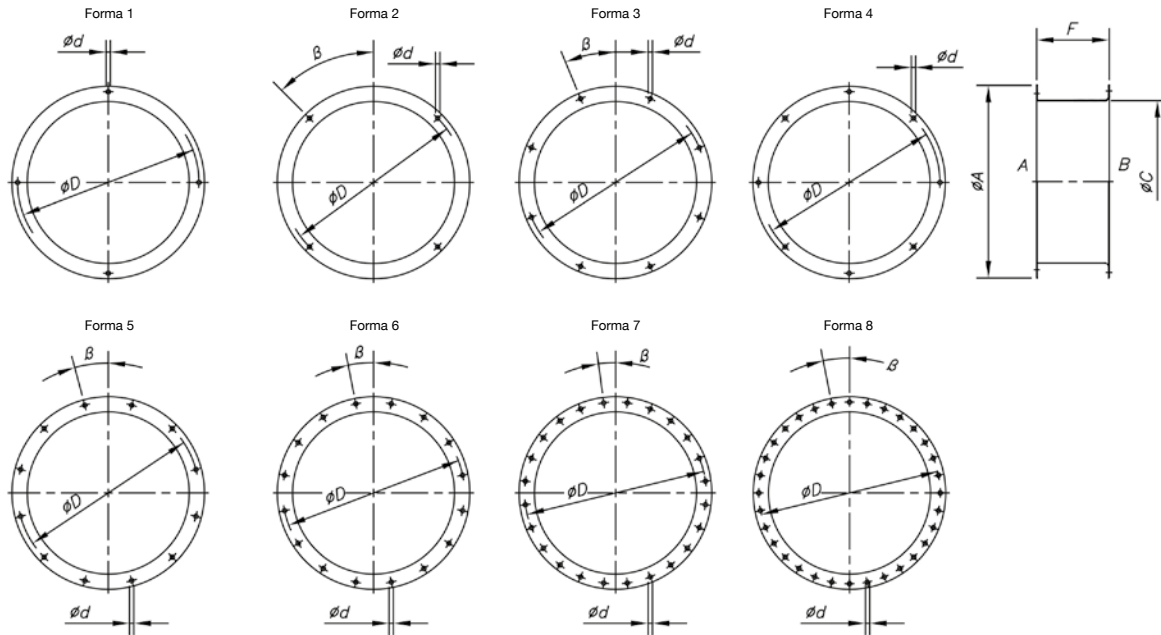

Modelo	ØA	ØC	ØD	Ød	F	β	Forma	Aplicable a	
								TCMP	TCR TCR/R
BD-112	160	112	137	7	60	45°	2		
BD-140	190	140	165	7	80	-	1		
BD-160	220	160	185	7	80	45°	2		
BD-160	220	160	185	7	80	-	1		
BD-180	240	180	205	7	80	11°15'	2		
BD-185	240	185	219	8	80	22°30'	3		
BD-200	260	200	225	7	80	-	1	820	
BD-200	260	200	225	7	80	22°30'	2		
BD-205	260	205	241	8	80	22°30'	3		
BD-224	280	224	254	7	80	-	1	922	
BD-228	280	228	265	8	80	22°30'	3		
BD-250/1	310	250	280	10	80	45°	2	1025	
BD-250/2	310	250	280	10	80	45°	2		
BD-255	310	255	292	10	80	22°30'	3		
BD-280	350	280	320	10	100	-	4	1128	
BD-285	350	285	332	10	100	22°30'	3		
BD-315/1	390	315	355	10	100	22°30'	3		
BD-315/2	390	315	355	10	100	22°30'	3		
BD-315/3	390	315	355	10	100	22°30'	3	1231	
BD-320	390	320	366	12	100	22°30'	3		
BD-355/1	430	355	395	10	100	22°30'	3		
BD-355/2	430	355	395	10	100	22°30'	3		
BD-355/3	430	355	395	10	100	22°30'	3	1435	
BD-360	430	360	405	12	100	22°30'	3		
BD-400/1	480	400	450	12	100	22°30'	3	1640	
BD-400/2	480	400	450	12	100	22°30'	3		1240

Modelo	ØA	ØC	ØD	Ød	F	β	Forma	Aplicable a	
								TCMP	TCR TCR/R
BD-405	480	405	448	12	100	15°	5		
BD-450/1	530	450	500	12	100	22°30'	3	1845	
BD-450/2	530	450	500	12	100	22°30'	3		1445
BD-455	530	455	497	12	100	15°	5		
BD-500/1	590	500	560	12	100	15°	5	2050	
BD-500/2	590	500	560	12	100	15°	5		1650
BD-505	590	505	551	12	100	15°	5		
BD-555	640	555	610	10	120	15°	5		
BD-560	650	560	620	12	120	15°	5		1856
BD-565	650	565	629	13	120	15°	5		
BD-630/1	720	630	690	12	120	15°	5		
BD-630/2	720	630	690	12	120	15°	5		2063
BD-635	720	635	698	15	120	15°	5		
BD-710	800	710	770	12	120	11°15'	6		2271
BD-715	800	715	775	15	120	11°15'	6		
BD-800	890	800	860	12	140	11°15'	6		
BD-805	890	805	861	15	140	11°15'	6		
BD-900/1	1000	900	958	14	140	11°15'	6		
BD-905	1000	905	958	14	140	11°15'	6		
BD-1000/1	1100	1000	1067	14	140	7°30'	7		
BD-1007	1100	1007	1067	15	140	7°30'	7		
BD-1130	1250	1130	1200	15	140	7°30'	7		
BD-1260	1380	1260	1337	15	160	7°30'	7		
BD-1410	1530	1410	1491	13	160	5°30'	8		
BD-1700	1820	1700	1770	16	180	5°30'	8		

ACCESORIOS

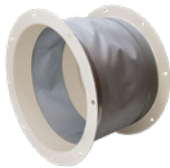

BAC

Brida de acoplamiento doble y elástica para ventiladores helicoidales

Características:

- Se adapta a la boca de aspiración y de impulsión.
- Facilita la instalación al conducto con brida.
- Evita la transmisión de vibraciones.

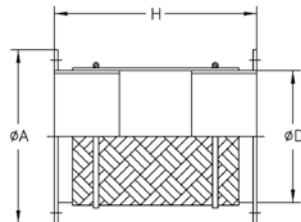

Aplicable a

Modelo	ØD*	ØA*	H	CHT/CVT	THT
BAC-160	160	220	240	-	-
BAC-180	180	240	240	-	-
BAC-250	250	310	340	200/225	-
BAC-315B	280	350	340	-	-
BAC-315	315	380	340	-	-
BAC-355	355	430	340	250/315	-
BAC-400	400	480	340	-	40
BAC-450	450	530	340	-	45
BAC-500	500	590	340	400/450	50
BAC-560	560	650	340	-	56
BAC-630	630	720	340	500	63
BAC-710	710	800	340	560/630	71
BAC-800	800	890	340	-	80
BAC-900	900	1000	340	-	90
BAC-1000	1000	1100	340	-	100
BAC-1250	1250	1365	340	-	125

* Diámetro nominal tubería recomendada.

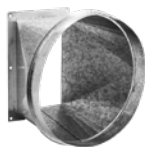

BIC

Brida conversión de rectangular a circular para ventiladores centrífugos

Características:

- Se adapta a la boca de impulsión.
- Facilita la instalación al conducto circular.

Modelo Aplicable a TCMP

BIC-820	820
BIC-922	922
BIC-1025	1025
BIC-1128	1128
BIC-1231	1231
BIC-1435	1435
BIC-1640	1640
BIC-1845	1845
BIC-2050	2050
BIC-2563	2563

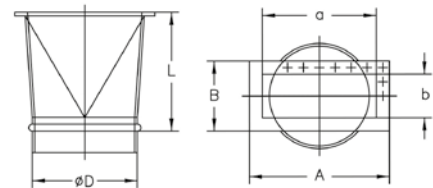

Modelo	L	D	a	b	A	B
BIC-540	300	180	140	120	224	206
BIC-545	300	180	170	135	255	222
BIC-550	300	224	200	150	296	246
BIC-752	300	224	200	160	296	256
BIC-760	300	250	220	180	316	276
BIC-880	300	315	290	190	360	249
BIC-270	300	270	300	162	370	221
BIC-1080	300	250	200	140	270	210
BIC-1090	300	280	224	160	294	230
BIC-1250	450	400	400	280	480	360
BIC-1456	450	450	450	315	530	395
BIC-1663	450	500	500	355	580	435
BIC-1671	450	630	560	400	660	500
BIC-2080	450	710	630	450	730	550
BIC-242	200	100	95	60	155	120
BIC-248	200	112	105	66	165	126
BIC-254	200	125	115	75	175	135
BIC-260	200	150	125	85	185	145
BIC-463	200	200	125	85	185	145
BIC-467	250	224	130	90	190	150
BIC-571	250	250	145	95	205	155
BIC-640	250	250	200	125	260	185
BIC-645	250	250	224	140	284	200
BIC-650	250	250	250	160	310	220
BIC-790	250	180	112	80	172	140
BIC-852	250	280	280	180	340	240
BIC-856	280	355	280	180	340	240
BIC-863	280	355	315	200	375	260
BIC-971	280	400	355	224	425	294
BIC-980	300	250	200	140	270	210
BIC-990	300	280	224	160	294	230
BIC-285	300	280	288	205	368	285

Modelo	L	D	a	b	A	B
BIC-320	300	320	322	229	402	309
BIC-450	300	450	404	288	484	368
BIC-185	300	180	166	117	236	187
BIC-200	300	200	185	131	255	201
BIC-230	300	230	207	148	277	218
BIC-250	300	250	231	166	301	236
BIC-280	300	280	258	185	328	255
BIC-325	300	320	288	205	368	285
BIC-360	300	360	322	229	402	309
BIC-400	300	400	361	256	441	336
BIC-1428	300	250	286	202	350	260
BIC-1733	300	280	339	240	415	315
BIC-2240	450	355	400	300	478	372
BIC-820-CB	300	200	160	130	213	184
BIC-1445/E	450	450	450	355	538	445
BIC-1650/E	450	500	500	400	590	490
BIC-1856/E	450	560	560	450	660	550
BIC-1025	300	250	250	165	314	229
BIC-1128	300	280	300	180	364	244
BIC-1231	300	315	320	200	384	266
BIC-1435	300	355	280	228	344	294
BIC-1640	300	400	320	250	404	336
BIC-1845	450	450	360	284	444	370
BIC-2050	450	500	450	315	545	412
BIC-2563	450	630	600	410	706	512
BIC-512	300	112	86	75	118	104
BIC-514	300	140	107	83	147	122
BIC-616	300	160	125	103	172	153
BIC-620	300	200	100	105	153	159
BIC-718	300	180	146	115	192	169
BIC-820	300	200	156	130	213	184
BIC-922	300	224	216	140	282	204

Modelo	L	D	a	b	A	B
BIC-1031	300	315	315	250	385	320
BIC-1135	450	355	355	280	425	350
BIC-1240	450	400	400	315	480	395
BIC-1445	450	450	450	355	540	445
BIC-1650	450	500	500	400	590	490
BIC-1856	450	560	560	450	660	550
BIC-2063	450	630	630	500	750	620
BIC-2271	450	710	710	560	840	690
BIC-2380	600	800	800	560	920	680
BIC-2590	600	900	900	630	1020	750
BIC-28100	600	1000	1000	710	1120	830
BIC-1120	600	1120	1130	801	1270	941
BIC-1200	600	1250	1267	898	1407	1038
BIC-1400	600	1400	1421	1007	1561	1147
BIC-355	300	350	361	256	441	336
BIC-560	450	560	569	404	669	504
BIC-635	450	630	638	453	738	553
BIC-710	450	710	715	507	815	607
BIC-1600	600	1600	1593	1130	1753	1290
BIC-1025-T	300	200	250	165	314	229
BIC-1128-T	300	224	300	180	364	244
BIC-1231-T	300	250	320	200	384	266
BIC-1435-T	300	280	280	228	344	294
BIC-1640-T	300	280	320	250	404	336
BIC-1845-T	450	355	360	284	444	370
BIC-2050-T	450	400	450	315	545	412
BIC-922-T	300	180	216	140	282	204
BIC-1840	150	370	273	210	353	303
BIC-2045	190	400	330	270	420	360
BIC-565	450	560	560	355	660	457
BIC-1650/M	500	500	507	361	587	441

ACCESORIOS



PS

Conjunto de pies soporte, para ventiladores tubulares

Características:

- Al fijarse a la brida facilita la fijación sobre superficies planas.

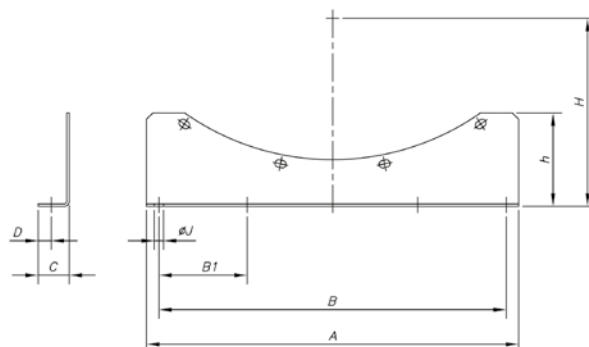

Modelo	A	B	B1	C	D	h	H	ØJ	Aplicable a THT
PS-31/E	300	225	-	25	10,5	100	205	10	-
PS-25/31	275	225	-	25	10,5	90	165	10	-
PS-25/31	275	225	-	25	10,5	90	191,5	10	-
PS-25/31	275	225	-	25	10,5	90	205	10	-
PS-35/40	240	200	-	30	13	60	230	10	-
PS-35/40	240	200	-	30	13	60	255,5	10	40
PS-45/50	450	400	200	35	14,5	125	278	12	45
PS-45/50	450	400	200	35	14,5	125	305	12	50
PS-56/63	520	430	215	40	17	155	338	13	56
PS-56/63	520	430	215	40	17	155	385,5	13	63
PS-71	490	450	225	50	21	150	445	13	71
PS-80	600	560	280	50	21	150	490	13	80
PS-90	620	560	280	60	28	175	547,5	18	90
PS-100	680	560	280	60	28	185	597,5	18	100
PS-125 <20CV	1000	900	3x300	60	28	285	726,5	18	125
PS-125 >25CV	1000	900	3x300	60	28	285	726,5	18	125
PS-140	1100	1000	4x250	60	30	306	800	14	140
PS-160	1300	1200	4x300	60	25	290	890	14	160

MS



Marco soporte para facilitar el montaje en obra

Características:

- Utilizado para facilitar el montaje del ventilador en conductos de obra.

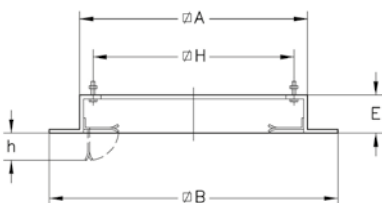

Modelo	ØA	ØB	E	ØH	h	Aplicable a CHT/CVT
MS-348	348	520	60	295	70	-
MS-393	393	565	60	320	70	-
MS-443	443	615	60	360	70	200/225
MS-493	493	665	60	410	70	-
MS-553	553	725	60	450	70	250/315
MS-623	623	795	60	530	70	-
MS-701	701	875	60	590	90	400/450
MS-791	791	965	60	680	90	-
MS-891	891	1065	60	750	90	500
MS-991	991	1165	60	850	90	-
MS-1086	1086	1260	60	850	90	560/630
MS-1140	1140	1314	60	1000	90	-
MS-1240	1240	1414	60	1100	90	-

ACCESORIOS

PA



Placa de adaptación para montaje de accesorios, en extractores de tejado

Características:

- Se utiliza para el montaje de los accesorios PT, B, BTUB, BAC. Permite separar el ventilador de su base sin desmontar el conjunto de accesorios.

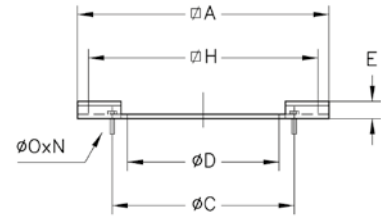

Modelo	∅A	∅C	∅D	E	∅H	∅O	N	Aplicable a CHT/CVT
PA-345	345	200	165	20	295	M.8	4x90"	-
PA-390	390	210	190	20	320	M.8	4x90"	-
PA-440/250	440	280	249	20	360	M.6	4x90"	200/225
PA-490	490	355	314	20	410	M.8	8x45"	-
PA-550	550	395	354	20	450	M.6	8x45"	250/315
PA-620	620	450	399	20	530	M.10	8x45"	-
PA-700/500	700	560	499	20	590	M.10	12x30"	400/450
PA-700/450	700	500	449	20	590	M.10	8x45"	-
PA-790	790	560	499	20	680	M.10	12x30"	-
PA-890/630	890	690	629	20	750	M.10	12x30"	500
PA-890/560	890	620	559	20	750	M.10	12x30"	-
PA-990/630	990	690	629	20	850	M.10	12x30"	-
PA-990/710	990	770	709	20	850	M.10	16x22"30'	-
PA-1085	1085	770	709	20	850	M.10	16x22"30'	560/630
PA-1138/800	1138	860	799	25	1000	M.10	16x22"30'	-
PA-1138/900	1138	970	899	25	1000	M.12	16x22"30'	-
PA-1238	1238	1070	999	25	1100	M.12	16x22"30'	-

BS



Base soporte elevada

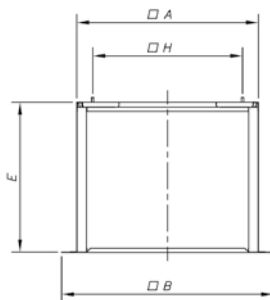

Modelo	A	B	H	E	Aplicable a CHT/CVT
BS-348	348	520	295	800	-
BS-393	393	565	320	800	-
BS-443	444	611	360	800	200/225
BS-493	493	665	410	800	-
BS-553	554	724	450	800	250/315
BS-623	623	795	530	800	-
BS-701	701	871	590	900	400/450
BS-791	791	965	680	900	-
BS-891	891	1071	750	900	500
BS-991	991	1165	850	900	-
BS-1086	1086	1266	900	900	560/630
BS-1140	1136	1310	1000	900	-
BS-1240	1237	1411	1100	900	-

BSS



Base soporte elevada con silenciador

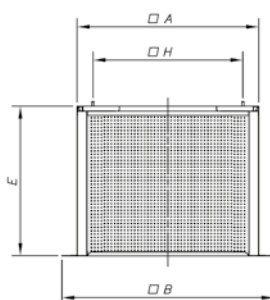

Modelo	A	B	H	E	Aplicable a CHT/CVT
BSS-348	348	520	295	800	-
BSS-393	393	565	320	800	-
BSS-443	444	611	360	800	200/225
BSS-493	493	665	410	800	-
BSS-553	554	724	450	800	250/315
BSS-623	623	795	530	800	-
BSS-701	701	871	590	900	400/450
BSS-791	791	965	680	900	-
BSS-891	891	1071	750	900	500
BSS-991	991	1165	850	900	-
BSS-1086	1086	1266	900	900	560/630
BSS-1140	1136	1310	1000	900	-
BSS-1240	1237	1411	1100	900	-

ACCESORIOS

PT



Obturadores de cierre automático para trabajo vertical. Versión 400 certificado 400 °C/2h

Características:

- Obturadores circulares de cierre automático para ser instalados en la aspiración de extractores de tejado.
- Aconsejable utilizar la placa de adaptación PA, para su montaje.

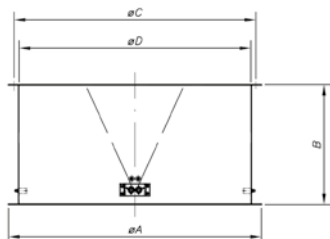

Modelo	øA	B	øC	øD	N	øO	Y
PT-160	220	150	200	150	8x45°	10	-
PT-180	240	150	210	170	8x45°	10	-
PT-250	310	150	280	245	4x90°	10	45
PT-355	435	200	395	350	8x45°	10	22°30'
PT-500	600	280	560	495	12x30°	12	15°
PT-630	730	355	690	625	12x30°	12	15°
PT-710	810	400	770	705	16x22°30'	12	11°15'

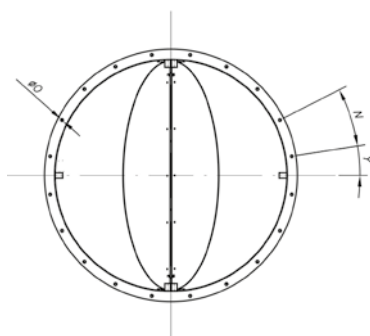

Modelo	øA	B	øC	øD	N	øO	Y	Aplicable a CHT/CVT
PT-160-400	220	150	200	150	8x45°	10	-	-
PT-180-400	240	150	210	170	8x45°	10	-	-
PT-250-400	310	150	280	245	4x90°	10	45	200/225
PT-355-400	435	200	395	350	8x45°	10	22°30'	250/315
PT-500-400	600	280	560	495	12x30°	12	15°	400/450
PT-630-400	730	355	690	625	12x30°	12	15°	500
PT-710-400	810	400	770	705	16x22°30'	12	11°15'	560/630

PT/H



Obturadores de cierre automático para trabajo horizontal. Versión 400 certificado 400 °C/2h

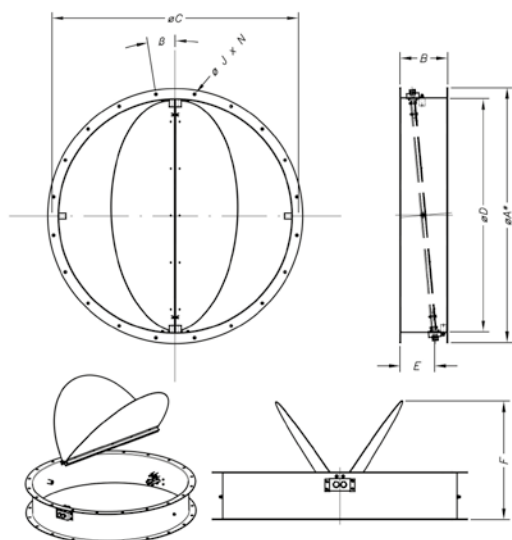

Modelo	øA	B	øC	øD*	E	F	øJ	N
PT-450/H PT-450/H-400	540	254	500	460	185	340	22°30'	12 8x45'
PT-500/H PT-500/H-400	600	254	560	514	185	346	15'	12 12x30'
PT-560/H PT-560/H-400	660	254	620	560	185	363	15'	12 12x30'
PT-630/H PT-630/H-400	730	254	690	640	185	409	15'	12 12x30'
PT-710/H PT-710/H-400	810	254	770	710	185	443	11°15'	12 16x22°30'
PT-800/H PT-800/H-400	900	254	860	800	185	488	11°15'	12 16x22°30'
PT-900/H PT-900/H-400	1015	254	970	900	185	555	11°15'	15 16x22°30'
PT-1000/H PT-1000/H-400	1115	254	1070	1000	185	609	11°15'	15 16x22°30'
PT-1250/H PT-1250/H-400	1365	254	1320	1250	185	736,5	9'	15 20x18'

* Diámetro nominal tubería recomendada.

ACCESORIOS

VIS



Viseras de impulsión con rejilla de protección

Características:

- Evita la entrada de objetos y agua al interior del ventilador.

Modelo	A	B	E	F	Aplicable a	
					CJMP	CJTCR/R
VIS-820	132	157	170	56,5	820	-
VIS-922	142	216	215	56,5	922	-
VIS-1025	167	251	240	56,5	1025	-
VIS-1128	182	296	270	56,5	1128	-
VIS-1231	202	321	290	56,5	1231	-
VIS-1240	317	401	350	56,5	-	1240
VIS-1435	232	281	260	56,5	1435	-
VIS-1445	357	451	385	56,5	-	1445
VIS-1640	252	321	290	56,5	1640	-
VIS-1650	402	501	420	56,5	-	1650
VIS-1845	286	361	320	56,5	1845	-
VIS-1856	452	561	465	56,5	-	1856
VIS-2050	317	451	385	56,5	2050	-
VIS-2063	502	631	515	56,5	-	2063
VIS-2271	562	716	575	56,5	-	2271

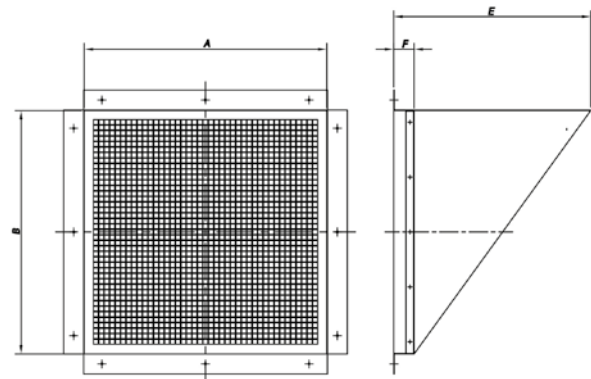

Modelo	A	B	E	F	Aplicable a
					CJLINE
VIS-1131	560	450	250	100	1131
VIS-1235	620	500	250	100	1235
VIS-1640/E	710	560	250	100	1640
VIS-1845/E	800	630	250	100	1845
VIS-1856/E	1000	800	250	100	1856
VIS-2063/E	1120	900	250	100	2063
VIS-2271/E	1190	900	250	100	2271
VIS-2880	1250	1000	250	100	2880

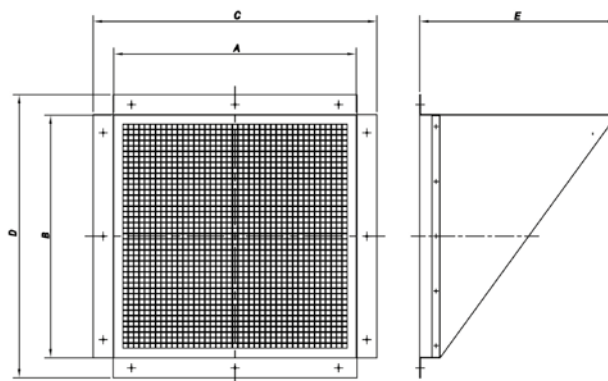

Modelo	A	B	C	D	E	Aplicable a CJS
VIS-100	600	600	698	698	485	1850
VIS-200	725	725	823	823	576	2263-6T
VIS-300	800	800	898	898	630	2263-4T/ 2071-6T-3
VIS-400	860	860	958	958	674	2071-4T/6T-5.5/2880

ACCESORIOS

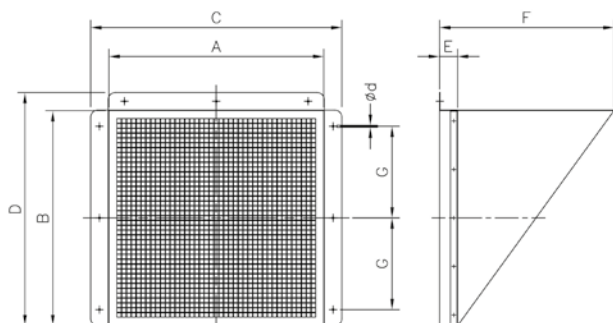

Modelo	Aplicable a		
	CJBD	CJBDT	CJTX-C
VIS-7/7	1919	-	7/7
VIS-9/9	2525	9/9	9/9
VIS-10/10	2828	10/10	10/10
VIS-12/12	3333	12/12	12/12
VIS-15/15	3939	15/15	15/15
VIS-18/18	-	18/18	18/18
VIS-20/20	-	20/20	20/20
VIS-22/22	-	22/22	22/22
VIS-25/25	-	-	25/25
VIS-30/28	-	-	30/28

Modelo		A	B	C	D	E	F	G	Ød
VIS-7/7	VIS-7/7-P	300	280	334	314	50	200	200	6xØ5
VIS-9/9	VIS-9/9-P	370	370	404	404	50	250	200	6xØ5
VIS-10/10	VIS-10/10-P	400	360	434	394	50	250	240	6xØ5
VIS-12/12		490	470	524	504	50	250	170	9xØ5
	VIS-12/12-P	430	410	464	444	50	250	175	9xØ5
VIS-15/15	VIS-15/15-P	550	530	584	564	50	400	200	9xØ5
VIS-18/18	VIS-18/18-P	630	600	664	634	50	400	200	9xØ5
VIS-20/20	VIS-20/20-P	760	690	794	724	50	400	200	9xØ5
VIS-22/22		950	820	984	854	50	400	200	15xØ5
	VIS-22/22-P	820	820	854	854	50	400	180	15xØ5
VIS-25/25		820	820	854	854	50	400	180	15xØ5
	VIS-25/25-P	950	820	984	854	50	400	200	15xØ5
VIS-30/28	VIS-30/28-P	1040	1100	1074	1134	50	400	200	15xØ5



ACE ACE/400

Acoplamiento elástico para amortiguar vibraciones

Características:

- Se utiliza entre la boca del ventilador y el conducto para evitar la transmisión de vibraciones.
- Es aconsejable añadir el accesorio B en la aspiración y BIC en la impulsión, excepto en los modelos CPV.

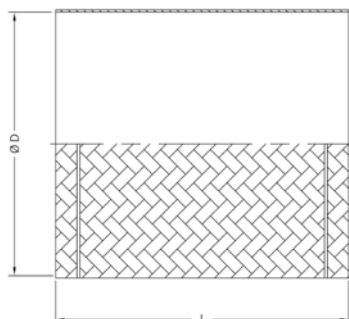

Modelo	ØD	L	Modelo	ØD	L
ACE-52	52	200	ACE-355	355	300
ACE-63	63	200	ACE-400	400	300
ACE-80	80	200	ACE-450	450	300
ACE-100	100	200	ACE-500	500	300
ACE-112	112	200	ACE-560	560	300
ACE-125	125	200	ACE-630	630	300
ACE-140	140	200	ACE-710	710	300
ACE-150	150	200	ACE-800	800	300
ACE-160	160	200	ACE-900	900	300
ACE-180	180	200	ACE-1000	1000	300
ACE-200	200	200	ACE-1130	1130	300
ACE-224	224	200	ACE-1260	1260	300
ACE-250	250	300	ACE-1410	1400	300
ACE-280	280	300	ACE-1610	1610	300
ACE-315	315	300			

Modelo	ØD	L	Aplicable a		
			THT	CJMP	CJTCR/R
ACE/400-200	200	200	-	820	-
ACE/400-224	224	200	-	922	-
ACE/400-250	250	300	-	1025	-
ACE/400-280	280	300	-	1128	-
ACE/400-315	315	300	-	1231	-
ACE/400-355	355	300	-	1435	-
ACE/400-400	400	300	40	1640	1240
ACE/400-450	450	300	45	1845	1445
ACE/400-500	500	300	50	2050	1650
ACE/400-560	560	300	56	-	1856
ACE/400-630	630	300	63	-	2063
ACE/400-710	710	300	71	-	2271
ACE/400-800	800	300	80	-	-
ACE/400-900	900	300	90	-	-
ACE/400-1000	1000	300	100	-	-
ACE/400-1250	1250	300	125	-	-

ACCESORIOS



TEJ

Tejadillos para intemperie

Características:

- Evita la entrada de agua, en unidades de ventilación instaladas en el exterior.

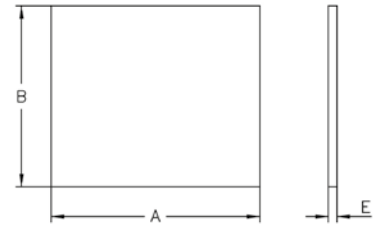

Modelo	A	B	E	Aplicable a	
				CJMP	CJTCR/R
TEJ-820	500	550	25	820	-
TEJ-922	710	710	25	922	-
TEJ-1025	760	760	25	1025	-
TEJ-1128	820	820	25	1128	-
TEJ-1231	900	900	25	1231	-
TEJ-1435	980	980	25	1435	-
TEJ-1640	1071	1070	26	1640	1240
TEJ-1845	1170	1170	26	1845	1445
TEJ-1856	1360	1150	26	-	1856
TEJ-2050	1260	1260	26	2050	1650
TEJ-2063	1500	1300	26	-	2063
TEJ-2271	1655	1455	26	-	2271

Modelo	A	B	E	Aplicable a
				CJTX-C
TEJ-7/7	710	740	30	7/7
TEJ-9/9	770	795	30	9/9
TEJ-10/10	835	870	30	10/10
TEJ-12/12	955	980	30	12/12
TEJ-15/15	1110	1110	30	15/15
TEJ-18/18	1260	1290	30	18/18
TEJ-20/20	1485	1505	30	20/20
TEJ-22/22	1635	1650	30	22/22
TEJ-25/25	1810	1835	30	25/25
TEJ-30/28	2010	2145	30	30/28

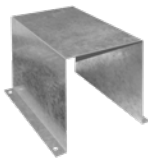

CM

Cubre motores para trabajos en intemperie

Características:

- Evita la entrada de agua, en motores instalados en el exterior.

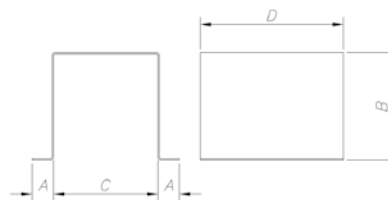

Modelo	A	B	C	D
CM-1	15	260	200	300
CM-2	15	260	240	300
CM-5.5	15	300	270	330
CM-10	15	380	320	450
CM-20	15	440	350	530
CM-30	15	440	360	550



TAC

Tapa de acoplamiento circular

Características:

- Para convertir la impulsión o aspiración rectangular de la unidad a circular.

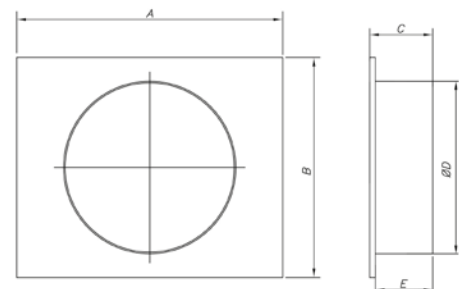

Modelo	A	B	C	ØD	E	Aplicable a	
						CJS	CJLINE
TAC-100	698	698	80	400	50	1850	-
TAC-200	823	823	80	560	50	2056/2263-6T	-
TAC-300	898	898	80	630	50	2263-4T/2071-6T-3	-
TAC-400	958	958	80	710	50	2071-4T/6T-5.5/2880	-
TAC-1131	615	505	165	400	150	-	1131
TAC-1235	695	575	165	450	150	-	1235
TAC-1640	785	635	165	500	150	-	1640
TAC-1845	875	705	165	560	150	-	1845
TAC-1856	1075	875	165	700	150	-	1856
TAC-2063	1195	975	165	800	150	-	2063
TAC-2271	1265	975	165	800	150	-	2271
TAC-2880	1325	1075	165	900	150	-	2880

ACCESORIOS

S



Silenciadores para acoplar a la aspiración o impulsión

Características:

- Silenciadores circulares o rectangulares para acoplar a la aspiración o impulsión, de ventiladores centrífugos o helicoidales.

Aspiración/Impulsión (Brida rectangular)

Amortiguación de sustitución (dB) en banda de octavos (Hz)

Modelo	L	a	b	Kg	125	250	500	1000	2000	4000	Aplicable a
SR-1000/900/900	900	1000	900	74	4	10	21	37	44	37	THT-63
SR-1200/900/900	900	1200	900	77	4	10	21	37	44	37	THT-71
SR-1400/1200/900	900	1400	1200	100	4	12	25	41	47	42	THT-80
SR-1800/1200/1200	1200	1800	1200	141	4	12	25	41	47	42	THT-90
SR-1800/1500/1200	1200	1800	1504	168	4	12	25	41	47	42	THT-100

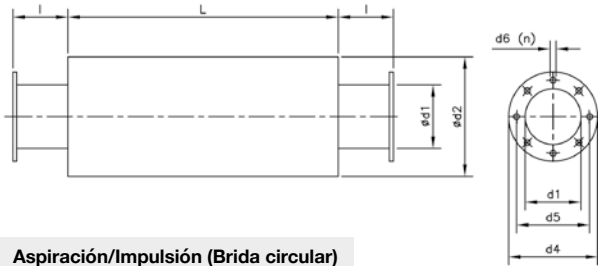
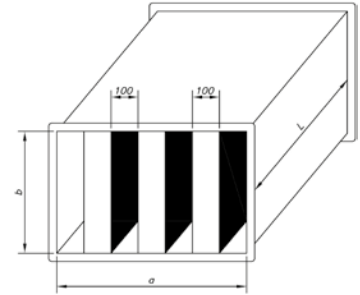

Aspiración/Impulsión (Brida circular)

Amortiguación de sustitución (dB) en banda de octavos (Hz)

Modelo	L	d1	d2	l	d4	d5	d6	n	Kg	125	250	500	1000	2000	4000	Aplicable a
SC-630/900	900	630	800	100	720	690	12	12x30°	51	5	8	14	12	13	9	THT-63
SC-710/900	900	710	900	100	800	770	12	16x22°30'	60	5	8	13	11	12	8	THT-71
SC-800/900	900	800	1000	100	900	860	12	16x22°30'	69	4	8	11	9	9	8	THT-80
SC-900/1200	1200	900	1120	100	1000	970	15	16x22°30'	100	5	7	11	11	7	5	THT-90
SC-1000/1200	1200	1000	1200	100	1100	1070	15	16x22°30'	106	4	7	11	10	7	6	THT-100

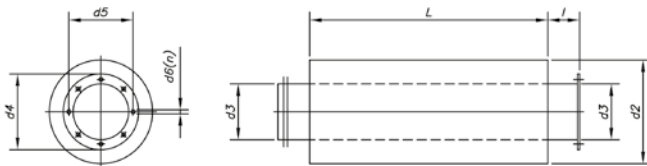

Aspiración

Amortiguación de sustitución (dB) en banda de octavos (Hz)

Modelo	L	d2	d3	d4	d5	d6	n	l	Kg	125	250	500	1000	2000	4000	Aplicable a
S-160/600-A	600	260	160	220	200	10	4x90°	100	9	3	11	22	33	42	29	-
S-180/600-A	600	300	180	240	210	10	4x90°	100	11	4	8	15	31	28	20	-
S-250/600-A	600	450	250	310	280	10	4x90°	100	18	5	12	20	24	23	14	CHT/CVT-200/225
S-315/900-A	900	500	315	390	355	10	8x45°	100	29	4	12	21	26	19	15	-
S-355/900-A	900	560	355	430	395	10	8x45°	100	34	4	12	20	24	18	14	CHT/CVT-250/315
S-400/900-A	900	600	400	480	450	12	8x45°	100	37	5	12	19	22	18	13	-
S-450/900-A	900	630	450	530	500	12	8x45°	100	38	5	12	18	20	16	12	-
S-500/900-A	900	710	500	590	560	12	12x30°	100	45	4	11	18	16	14	11	CHT/CVT-400/450
S-560/900-A	900	750	560	650	620	12	12x30°	100	47	4	10	16	14	13	10	-
S-630/900-A	900	800	630	720	690	12	12x30°	100	50	5	8	14	12	13	9	CHT/CVT-500
S-710/900-A	900	900	710	800	770	12	16x22°30'	100	58	5	8	13	11	12	8	CHT/CVT-560/630
S-800/900-A	900	1000	800	900	860	12	16x22°30'	100	67	4	8	11	9	9	8	-
S-900/1200-A	1200	1120	900	1000	970	12	16x22°30'	100	98	5	7	11	11	7	6	-
S-1000/1200-A	1200	1200	1000	1100	1070	12	16x22°30'	100	103	4	7	11	10	7	6	-

ACCESORIOS

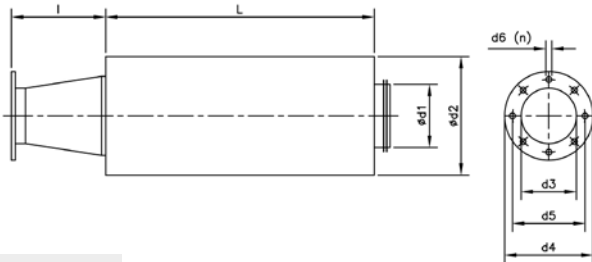

Modelo	L	d1	d2	l	d3	d4	d5	d6	n	Kg	Amortiguación de sustitución (dB) en banda de octavos (Hz)						Aplicable a
											125	250	500	1000	2000	4000	
S-80/600/218-A	600	80	280	103	80	113	95	6	4x90°	9	17	26	29	53	53	45	
S-100/600/324-A	600	100	300	108	80	130	112	6	4x90°	10	13	23	34	46	52	40	
S-125/600/325-A	600	125	315	114	94	140	122	7	4x90°	11	11	20	30	40	45	30	
S-150/600/426-A	600	150	355	132	117	155	132	7	4x90°	13	10	19	29	37	42	25	
S-150/600/527-A	600	150	355	114	125	170	147	7	4x90°	13	10	19	29	37	42	25	
S-160/600/528-A	600	160	355	107	135	190	162	7	4x90°	14	9	16	28	33	37	21	
S-200/600/531-A	600	200	400	135	160	215	180	7	4x90°	16	6	12	22	28	28	18	
S-250/600/540-A	600	250	450	204	170	240	205	11	4x90°	20	5	12	20	24	23	14	
S-315/900/545-A	900	315	500	266	180	255	220	11	4x90°	32	4	12	21	26	19	15	
S-100/600/242-A	600	100	300	115	100	150	130	10	8x45°	11	13	23	34	46	52	40	
S-150/900/248-A	900	150	355	200	112	160	140	10	8x45°	19	10	27	37	51	53	37	
S-160/900/254-A	900	160	355	200	125	180	155	10	8x45°	19	11	24	35	49	51	27	
S-200/900/260-A	900	200	400	200	150	210	175	10	8x45°	23	8	18	28	40	37	23	
S-200/900/463-A	900	200	400	200	200	260	240	10	8x45°	23	8	18	28	40	37	23	
S-250/900/467-A	900	250	450	200	224	280	258	10	8x45°	27	6	17	30	34	28	17	
S-250/900/571-A	900	250	450	200	250	310	275	10	8x45°	27	6	17	30	34	28	17	
S-250/600/640-A	600	250	450	200	250	310	275	10	8x45°	20	5	12	20	24	23	14	
S-315/900/645-A	900	315	500	200	250	310	275	10	8x45°	31	4	12	21	26	19	15	
S-355/900/650-A	900	355	560	200	250	310	275	10	8x45°	37	4	12	20	24	18	14	
S-180/900/680-A	900	180	380	100	165	235	200	11	8x45°	21	9	21	31	44	44	25	
S-180/900/790-A	900	180	380	100	185	235	219	11	8x45°	21	9	21	31	44	44	25	
S-355/900/852-A	900	355	560	200	280	350	310	10	8x45°	37	4	12	20	24	18	14	
S-400/1200/856-A	1200	400	600	200	355	430	395	10	8x45°	51	7	16	22	29	22	15	
S-400/1200/863-A	1200	400	600	200	355	430	410	10	8x45°	51	7	16	22	29	22	15	
S-450/1200/971-A	1200	450	630	200	400	480	450	12	8x45°	53	6	15	21	25	20	14	
S-250/1200/980-A	1200	250	450	100	255	325	292	11	8x45°	33	9	22	35	39	33	20	
S-280/1200/990-A	1200	280	450	100	286	366	332	11	8x45°	33	8	18	31	38	28	19	
S-250/1200/1080-A	1200	250	450	100	255	325	292	11	8x45°	33	9	22	35	39	33	20	
S-280/1200/1090-A	1200	280	450	100	286	366	332	11	8x45°	33	8	18	31	38	28	19	
S-500/900/1250-A	900	500	710	300	361	441	405	11,5	8x45°	54	6	13	18	15	15	12	
S-560/900/1456-A	900	560	750	450	406	486	448	11,5	12x30°	61	5	8	13	11	12	8	
S-630/1200/1663-A	1200	630	800	450	568	668	629	11,5	16x22°30'	79	4	8	11	9	9	8	
S-80/600/234-A	600	80	280	108	98	130	115	5	6x60°	10	17	26	29	53	53	45	
S-100/600/142-A	600	100	300	108	90	160	130	9	4x90°	11	13	23	34	46	52	40	
S-150/900/148-A	900	150	355	149	100	170	140	9	4x90°	19	10	27	37	51	53	37	
S-160/900/154-A	900	160	355	146	115	183	155	11	4x90°	19	11	24	35	49	51	27	
S-200/900/160-A	900	200	400	183	130	230	192	11	4x90°	23	8	18	28	40	37	23	
S-200/900/166-A	900	200	400	162	140	230	200	11	4x90°	23	8	18	28	40	37	23	
S-200/900/172-A	900	200	400	149	148	230	200	11	4x90°	23	8	18	28	40	37	23	
S-250/600/540-C-A	600	250	450	204	170	240	205	11	4x90°	20	5	12	20	24	23	14	
S-315/900/545-C-A	900	315	500	266	165	235	205	11	4x90°	32	4	12	21	26	19	15	
S-355/900/550-A	900	355	560	293	210	278	258	9	6x60°	38	4	12	20	24	18	14	
S-355/900/752-A	900	355	560	260	220	278	258	9	6x60°	38	4	12	20	24	18	14	
S-355/1200/760-A	1200	355	560	224	246	322	280	10	6x60°	47	7	15	25	32	23	17	
S-500/1200/880-A	1200	500	710	360	290	360	330	10	12x30°	69	7	15	25	32	23	17	
S-315/600/922-A	600	315	500	238	220	278	256	9	8x45°	24	4	8	14	17	14	12	TCMP-922
S-355/900/1025-A	900	355	560	224	245	305	282	9	8x45°	37	4	12	20	24	23	14	TCMP-1025
S-400/900/1128-A	900	400	600	250	270	348	320	9	8x45°	42	5	12	19	22	18	13	TCMP-1128
S-450/900/1231-A	900	450	630	291	295	382	354	9	8x45°	46	5	12	18	20	16	12	TCMP-1231
S-500/900/1435-A	900	500	710	284	345	422	394	9	8x45°	54	4	11	18	16	14	11	TCMP-1435
S-500/900/1640-A	900	500	710	227	395	464	438	9	8x45°	52	4	11	18	16	14	11	TCMP-1640

ACCESORIOS

Modelo	L	d1	d2	l	d3	d4	d5	d6	n	Kg	Amortiguación de sustitución (dB) en banda de octavos (Hz)						Aplicable a
											125	250	500	1000	2000	4000	
S-560/900/1845-A	900	560	750	241	445	515	485	9	8x45°	56	4	10	16	14	13	10	TCMP-1845
S-630/1200/2050-A	1200	630	800	269	495	565	535	11	8x45°	77	6	13	18	15	15	12	TCMP-2050
S-800/1200/2563-A	1200	800	1000	370	595	710	675	14	8x45°	112	5	9	13	11	11	9	TCMP-2563
S-400/900/1031-A	900	400	600	202	320	383	356	9	8x45°	41	5	12	19	22	18	13	TCR-R-1031
S-450/900/1135-A	900	450	630	216	345	425	398	9	8x45°	44	5	12	18	20	16	12	TCR-R-1135
S-500/900/1240-A	900	500	710	227	395	472	444	11	8x45°	52	4	11	18	16	14	11	TCR-R-1240
S-560/900/1445-A	900	560	750	241	445	522	494	11	8x45°	56	4	10	16	14	13	10	TCR-R-1445
S-630/1200/1650-A	1200	630	800	269	495	582	555	11	8x45°	77	6	13	18	15	15	12	TCR-R-1650
S-710/900/1856-A	900	710	900	301	555	645	615	11	8x45°	75	5	8	13	11	12	8	TCR-R-1856
S-800/900/2063-A	900	800	1000	329	625	720	688	11	8x45°	88	4	8	11	9	9	8	TCR-R-2063
S-800/1200/2271-A	1200	800	1000	224	705	800	768	13	8x45°	100	5	9	13	11	11	9	TCR-R-2271
S-800/1200/2380-A	1200	800	1000	224	800	906	861	13	16x22°	92	5	9	13	11	11	9	TCR-R-2380

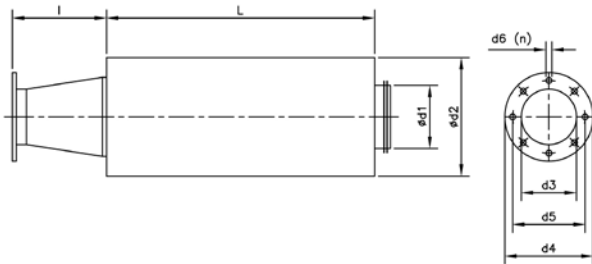

Impulsión (Brida circular)

Modelo	L	d1	d2	l	d3	d4	d5	d6	n	Kg	Amortiguación de sustitución (dB) en banda de octavos (Hz)					
											125	250	500	1000	2000	4000
S-80/600/218-I	600	80	280	103	54	90	76	6	4x90°	9	17	26	29	53	53	45
S-100/600/324-I	600	100	300	131	62	110	90	7	4x90°	10	13	23	34	46	52	40
S-125/600/325-I	600	125	315	142	80	120	102	7	4x90°	10	11	20	30	40	45	30
S-150/600/426-I	600	150	355	176	90	140	119	7	4x90°	12	10	19	29	37	42	25
S-150/600/527-I	600	150	355	149	100	155	129	7	4x90°	12	10	19	29	37	42	25
S-160/600/528-I	600	160	355	138	130	190	160	11	4x90°	12	9	16	28	33	37	21
S-200/600/531-I	600	200	400	162	140	200	175	11	4x90°	14	6	12	22	28	28	18
S-250/600/540-I	600	250	450	217	150	220	190	13	4x90°	17	5	12	20	24	23	14
S-315/900/545-I	900	315	500	266	175	250	220	13	4x90°	26	4	12	21	26	19	15
S-80/600/234-I	600	80	280	103	40	100	72	9	2x180°	9	17	26	29	53	53	45
S-100/600/142-I	600	100	300	131	60	120	90	11	4x90°	10	13	23	34	46	52	40
S-150/900/148-I	900	150	355	176	73	150	110	11	4x90°	17	10	27	37	51	53	37
S-160/900/154-I	900	160	355	190	80	160	120	13	4x90°	17	11	24	35	49	51	27
S-200/900/160-I	900	200	400	245	85	160	120	13	4x90°	20	8	18	28	40	37	23
S-200/900/166-I	900	200	400	245	85	160	120	13	4x90°	20	8	18	28	40	37	23
S-200/900/172-I	900	200	400	245	90	175	140	13	4x90°	20	8	18	28	40	37	23

ACCESORIOS

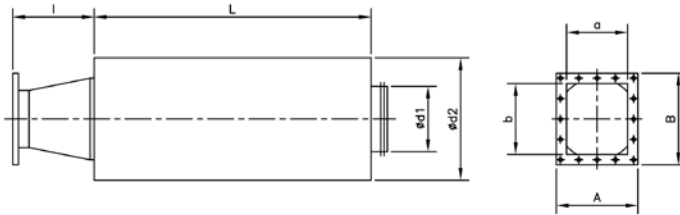

Impulsión (Brida rectangular)

Amortiguación de sustitución (dB) en banda de octavos (Hz)

Modelo	L	d1	d2	l	a	b	A	B	Kg	125	250	500	1000	2000	4000	Aplicable a
S-100/600/242-I	600	100	300	200	95	60	155	120	10	13	23	34	46	52	40	
S-150/900/248-I	900	150	355	200	105	66	165	126	18	10	27	37	51	53	37	
S-160/900/254-I	900	160	355	200	115	75	175	135	18	11	24	35	49	51	27	
S-200/900/260-I	900	200	400	200	125	85	185	145	21	8	18	28	40	37	23	
S-200/900/463-I	900	200	400	200	125	85	185	145	21	8	18	28	40	37	23	
S-250/900/467-I	900	250	450	250	130	90	190	150	25	6	17	30	34	28	17	
S-250/900/571-I	900	250	450	250	145	95	205	155	25	6	17	30	34	28	17	
S-250/600/640-I	600	250	450	250	200	125	260	185	18	5	12	20	24	23	14	
S-315/900/645-I	900	315	500	250	224	140	284	200	28	4	12	21	26	19	15	
S-355/900/650-I	900	355	560	250	250	160	310	220	32	4	12	20	24	18	14	
S-180/900/680-I	600	180	380	100	71	100	131	160	14	9	21	31	44	44	25	
S-180/900/790-I	600	180	380	100	80	112	140	172	14	9	21	31	44	44	25	
S-355/900/852-I	900	355	560	250	280	180	340	240	32	4	12	20	24	18	14	
S-400/1200/856-I	1200	400	600	280	280	180	340	240	44	7	16	22	29	22	15	
S-400/1200/863-I	1200	400	600	280	315	200	375	260	44	7	16	22	29	22	15	
S-450/1200/971-I	1200	450	630	280	355	224	425	294	46	6	15	21	25	20	14	
S-250/1200/980-I	1200	250	450	100	140	200	210	270	30	9	22	35	39	33	20	
S-280/1200/990-I	1200	280	450	100	160	224	230	294	29	8	18	31	38	28	19	
S-250/1200/1080-I	1200	250	450	100	140	200	210	270	30	9	22	35	39	33	20	
S-280/1200/1090-I	1200	280	450	100	160	224	230	294	29	8	18	31	38	28	19	
S-500/900/1250-I	900	500	600	300	280	400	360	480	30	6	13	18	15	15	12	
S-560/900/1456-I	900	560	630	450	315	450	395	530	32	5	8	13	11	12	8	
S-630/1200/1663-I	1200	630	750	450	355	500	435	580	53	4	8	13	11	11	9	
S-250/600/540-C-I	600	250	450	300	140	120	224	206	18	5	12	20	24	23	14	
S-315/900/545-C-I	900	315	500	300	170	135	255	222	28	4	12	21	26	19	15	
S-355/900/550-I	900	355	560	300	200	150	296	246	33	4	12	20	24	18	14	
S-355/900/752-I	900	355	560	300	200	160	296	256	33	4	12	20	24	18	14	
S-355/1200/760-I	1200	355	560	300	220	180	316	276	41	7	15	25	32	23	17	
S-500/1200/880-I	1200	500	710	300	290	190	360	249	55	7	15	25	32	23	17	
S-315/600/922-I	600	315	500	300	216	140	282	204	21	4	8	14	17	14	12	TCMP-922
S-355/900/1025-I	900	355	560	300	250	165	314	229	33	4	12	20	24	23	14	TCMP-1025
S-400/900/1128-I	900	400	600	300	300	180	364	244	36	5	12	19	22	18	13	TCMP-1128
S-450/900/1231-I	900	450	630	300	320	200	384	266	37	5	12	18	20	16	12	TCMP-1231
S-500/900/1435-I	900	500	710	300	280	228	344	294	44	4	11	18	16	14	11	TCMP-1435
S-500/900/1640-I	900	500	710	300	320	250	404	336	44	4	11	18	16	14	11	TCMP-1640
S-560/900/1845-I	900	560	750	450	360	284	444	370	48	4	10	16	14	13	10	TCMP-1845
S-630/1200/2050-I	1200	630	800	450	450	315	545	412	62	6	13	18	15	15	12	TCMP-2050
S-800/1200/2563-I	1200	800	1000	450	600	410	706	512	83	5	9	13	11	11	9	TCMP-2563
S-400/900/1031-I	900	400	600	300	315	250	385	320	36	5	12	19	22	18	13	TCR-R/TCR-1031
S-450/900/1135-I	900	450	630	450	355	280	425	350	38	5	12	18	20	16	12	TCR-R/TCR-1135
S-500/900/1240-I	900	500	710	450	400	315	480	395	46	4	11	18	16	14	11	TCR-R/TCR-1240
S-560/900/1445-I	900	560	750	450	450	355	540	445	48	4	10	16	14	13	10	TCR-R/TCR-1445
S-630/1200/1650-I	1200	630	800	450	500	400	590	490	62	6	13	18	15	15	12	TCR-R/TCR-1650
S-710/900/1856-I	900	710	900	450	560	450	660	550	58	5	8	13	11	12	8	TCR-R/TCR-1856
S-800/900/2063-I	900	800	1000	450	630	500	750	620	67	4	8	11	9	9	8	TCR-R/TCR-2063
S-800/1200/2271-I	1200	800	1000	450	710	560	840	690	83	5	9	13	11	11	9	TCR-R/TCR-2271
S-800/1201/2380-I	1200	800	1000	450	560	800	680	920	83	5	9	13	11	11	9	TCR-R/TCR-2380

ACCESORIOS



SC

Silenciadores para acoplar a la aspiración o a la impulsión

Características:

- Silenciadores circulares para acoplar a la aspiración o impulsión de extractores en línea.
- Silenciadores equipados con cuello para acople de conductos circulares.

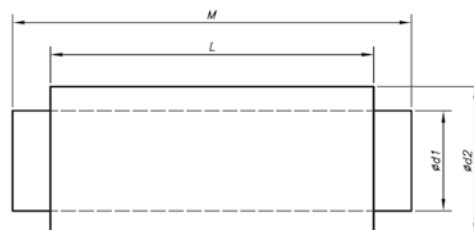

Atenuación acústica

Modelo	Ød1	Ød2	L	M	63	125	250	500	1000	2000	4000	8000
SC-125	125	225	600	720	1,1	2,9	8,8	19,4	27,2	34,1	27,2	13,4
SC-160	160	260	600	720	1,0	2,9	7,2	16,5	23,4	29,6	20,3	9,2
SC-200	200	300	600	720	1,0	2,9	7,0	14,6	20,3	25,8	15,6	6,8
SC-250	250	355	600	720	0,2	2,1	7,2	12,5	18,8	23,0	10,3	5,2
SC-315	315	415	600	720	0,2	2,1	7,2	10,3	15,0	20,0	7,0	3,9
SC-355	355	450	700	820	3,6	4,2	6,5	13,2	14,2	4,0	7,9	7,2



SI-PIR

Detector de presencia

Activa automáticamente el sistema de ventilación cuando detecta la presencia de personas en su radio de acción y se mantiene en funcionamiento por un tiempo prefijado, regulable mediante reloj interno.



Modelo	Alimentación	Salida	Ángulo de detección	Reglajes	Altura instalación	Temperatura de utilización
SI-PIR-TFT-550-B	24 V AC/24 V DC	24 V AC/24 V DC	110° C	Temporización: 5 s-30 min	1,8-3,6 m	-20° +50° C
SI-PIR-TF-25-360	24 V AC/24 V DC	24 V AC/24 V DC	360° C	Temporización: 10 s-30 min	2,4-4,2 m	-20° +50° C



SI-TEMP+HUMEDAD

Sensor de temperatura y humedad relativa con display

Controla independientemente la temperatura y la humedad relativa del aire ambiente del local. Activa automáticamente el sistema de ventilación cuando detecta una temperatura o humedad superior al punto de consigna. Una vez la temperatura o humedad ambiente ha descendido por debajo del punto de consigna, el ventilador permanece en funcionamiento por un tiempo prefijado, regulable mediante reloj interno.

Modelo	Alimentación	Salida	Reglajes	Altura instalación	Temperatura de utilización
SI-TEMP+HUMEDAD	24 V AC	0-10 V DC	$\Delta T = 0,5^{\circ}\text{C}$ y $\Delta \text{HR} = 2\%$	1,5-2,5 m	+10° +40° C

ACCESORIOS

SI-PRESIÓN



Transmisor de presión

Controla la presión en instalaciones de ventilación en presión constante, y la transforma en una señal eléctrica, para regular el sistema de ventilación y mantener siempre la misma presión.

Modelo	Alimentación	Salida	Consumo máximo (VA)	Conectores Ø	Rango de presión
SI-PRESIÓN TPDA	24 V AC/24 V DC	0-10 V/4-20 mA	4	6,2 mm	0-2500 Pa
SI-PRESIÓN TPDA c/DISPLAY	24 V AC/24 V DC	0-10 V/4-20 mA	4	6,2 mm	0-2500 Pa

SI-FUENTE DE ALIMENTACIÓN



Fuente de alimentación 24 V DC/AC

Alimenta los sensores inteligentes de 24 V DC/AC, a partir de una entrada de tensión de 230 V monofásica.



Modelo	Alimentación	Salida	Potencia (VA)
SI-FUENTE DE ALIMENTACIÓN DC	230 V	24 V DC	30
SI-FUENTE DE ALIMENTACIÓN AC	230/400 V	24/48 V AC	25

SI-VENT



Sensor de viento

El controlador electrónico de viento SI-VENT, es un dispositivo de gran robustez y fiabilidad, compuesto de una sonda de captación, un controlador y la fuente de alimentación. El sensor es capaz de medir vientos hasta 100 km/h y el controlador pone en funcionamiento el extractor eléctrico, cuando la velocidad del viento está durante 5 minutos, por debajo del valor de velocidad mínima programada.

SI-PRESOSTATO



Presostato

Controla la diferencia de presión entre filtros, una vez llega al valor seleccionado dispara un contacto para activar un relé de alarma.

PDS LOBBY CONTROL

Cuadro de control y regulación automática independiente para sistemas de presurización de vestíbulos



Cuadro de control y regulación automática independiente para sistemas de presurización de vestíbulos según norma EN 12101-6, compatible con los sistemas KIT BOXPDS y KIT BOXPDS SMART actuando como sensor de presión remoto, y con control automático de compuertas para mantener la sobrepresión en los vestíbulos en caso de incendio.

El cuadro PDS LOBBY CONTROL incluye:

- Sensor de presión diferencial de gran precisión integrado.
- Pantalla LCD y controles para programación de todas las funciones.
- Conexión Modbus RTU para comunicación con KIT BOXPDS y KIT BOXPDS SMART, o para conectar a sistema BMS.
- Activación desde central de incendios mediante contacto libre de potencial configurable.
- Control OPEN/CLOSE de dos compuertas motorizadas independientes de aportación y/o escape de aire.

- Control de una compuerta motorizada de apertura proporcional mediante señal 0-10 VDC, para aportación o escape de aire.
- Activación manual mediante contacto libre de potencial configurable.
- Activación local mediante sensor de humos autónomo analógico 4-20 mA.
- Envoltorio con grado de protección IP54.
- Rango temperatura de trabajo -10 °C +50 °C.
- Alimentación: seleccionable entre 230 V AC 50/60 Hz o 24 V DC.
- Salidas de relé libre de potencial configurable NO/NC: STATUS (OK o FALLO).
- Salidas de relé libre de potencial configurable NO/NC: Confirmación activación a central de incendios.

Fácil configuración del sistema a través del panel de control mediante pulsadores y pantalla LCD.

Características técnicas

Modelo	Tensión de alimentación (V)	Intensidad nominal (A)	Rango de presión (Pa)	Temperatura de trabajo (°C)	Peso aprox. (Kg)	Índice de protección
PDS LOBBY CONTROL	230 V AC 50/60 Hz	0.6	0-2500	-10 a +50	0.9	IP 54
	24 V DC	0.6	0-2500	-10 a +50	0.9	IP 54

Dimensiones mm

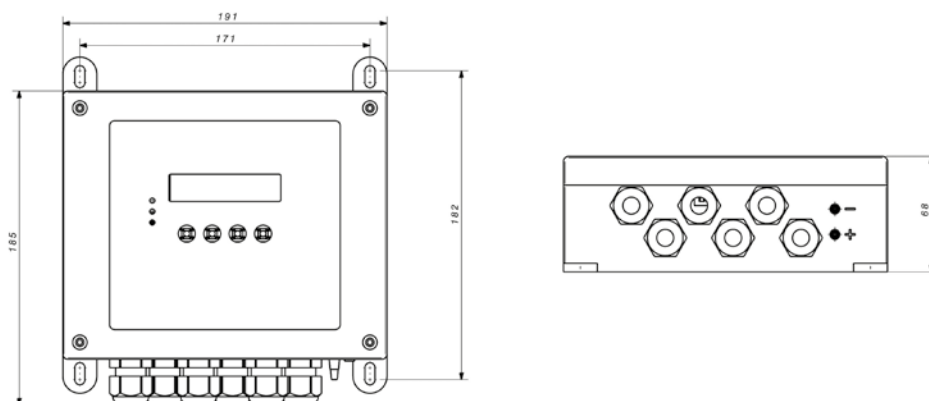

Conexiones

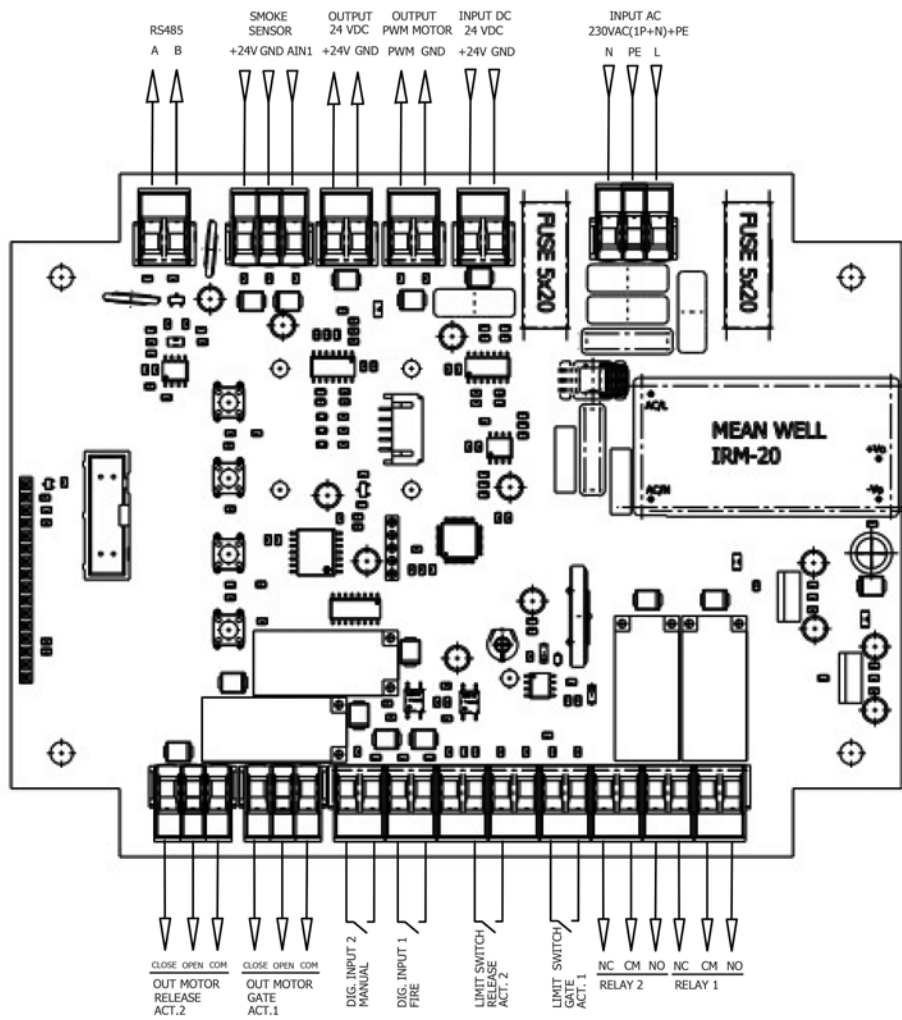

DAMPER BOX DAMPER BOX SMART



Compuerta motorizada con detector óptico de humo incorporado para sistemas de presurización



DAMPER BOX

- Compuerta motorizada con detector óptico de humos analógico incorporado compatible con sistemas de presurización KIT BOXPDS.

DAMPER BOX SMART

- Compuerta motorizada con detector óptico de humos de alta sensibilidad, con reset automático y gestión de alarmas incorporado compatible con sistemas de presurización KIT BOXSMART y KIT BOXPDS SMART.

Características:

- Compuerta multilama para aportación de aire en sistemas de presurización.
- La compuerta se adapta directamente sobre la unidad de ventilación CJHCH o en conducto.
- Construcción en chapa de acero galvanizado y lamas en chapa de aluminio.
- Lamas aerodinámicas con disposición opuesta y junta de estanqueidad.

- Detector óptico de humo para garantizar admisión de aire limpio. En caso de detección de humo la compuerta se cierra desde cuadro de control de presurización BOXSMART, KIT BOXPDS o KIT BOXPDS SMART.
- Tapa de registro para mantenimiento.

Sistema de apertura:

- Apertura y cierre mediante actuador de compuerta rápido.
- Tiempo de apertura y cierre 2,5 segundos.
- Alimentación AC/DC 24 V 50/60 Hz.
- Contactos auxiliares para monitorización de compuerta abierta o cerrada.

Bajo demanda:

- DAMPER BOX AF y DAMPER BOX SMART AF con sistema AntiFrost con resistencia calefactora de luz ultravioleta y termostato ajustable para evitar la acumulación de escarcha en la compuerta en climas fríos.

Código de pedido

DAMPER BOX — 56/63 — AF

DAMPER BOX: Compuerta motorizada con detector óptico de humo incorporado compatible con sistemas de presurización KIT BOXPDS
DAMPER BOX SMART: Compuerta motorizada con detector óptico de humo incorporado compatible con sistemas de presurización KIT BOXSMART y KIT BOXPDS SMART

Diámetro ventilador compatible

Sistema AntiFrost

Dimensiones mm

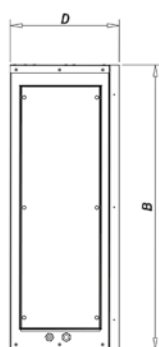
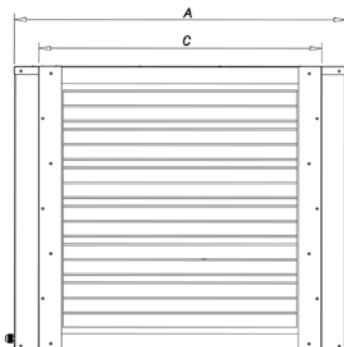

	A	B	C	D
DAMPER BOX 56/63	835	690	690	326,5
DAMPER BOX 71/80	995	850	850	326,5
DAMPER BOX 90/100	1195	1050	1050	326,5
DAMPER BOX SMART 56/63	835	690	690	350
DAMPER BOX SMART 71/80	995	850	850	350
DAMPER BOX SMART 90/100	1195	1050	1050	350

Bx C: Medidas conducto.

SCDLS-MA

Compuertas de control de humo de compartimento único con accionamiento manual y automático



Características:

- Compuerta rectangular de 200 x 200 mm a 1200 x 1200 mm.
- Certificación CE según EN 12101-8.
- Ensayada según norma EN 1366-10.
- Prueba de ciclos clase Cmod según EN 12101-8.
- Accionamiento de la compuerta mediante un actuador eléctrico de 24 V o 230 V.
- Fugas externas de la carcasa Clase B, fugas internas Clase 3 según EN 1751.
- Para instalación en posición vertical u horizontal.
- Clasificada según EN 13501-4+A1 como EIS 120/600, actuando MA o AA en compartimento único.
- Velocidad máxima recomendable de 12 m/s, presión permitida hasta 500 Pa, o depresión hasta -1500 Pa.
- Compuerta de 250 mm de ancho.
- Diseñada para sistemas con activación automática o manual.
- La compuerta se suministra con bridas.
- Temperatura de trabajo: -30 °C +50 °C.

Código de pedido



Diseño de la compuerta

Dígito adicional

Con actuador BEN, BEE, BE a 230 V	.44
Con actuador BEN, BEE, BE a 24 V	.54
Con actuador BEN (BEE)-SR a 24 V	.65*
Con el dispositivo de comunicación y alimentación BKNE 230-24 y el mecanismo de accionamiento BEN (BEE, BE)-ST para 24 V	.66

* El diseño .65 no está disponible con el actuador BE.

SCDRS-MA

Compuertas de control de humo circulares de compartimento único con accionamiento manual o automático

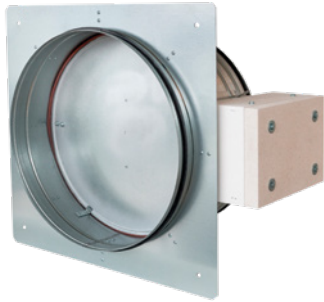

Características:

- Compuerta circular de \varnothing 100 a 630 mm.
- Certificación CE según EN 12101-8.
- Ensayada según norma EN 1366-10.
- Clasificada según EN 13501-4+A1 como EIS 120/600, actuando MA o AA en compartimento único.
- Fugas externas de la carcasa Clase C, fugas internas Clase 4.
- Prueba de ciclos clase Cmod según EN 12101-8.
- Accionamiento de la compuerta mediante un actuador eléctrico de 24 V o 230 V.
- Velocidad máxima recomendable de 15 m/s, presión permitida hasta 500 Pa, o depresión hasta -1500 Pa.
- Diseñada para sistemas con activación automática o manual.
- Temperatura de trabajo: -30 °C +50 °C.

Código de pedido

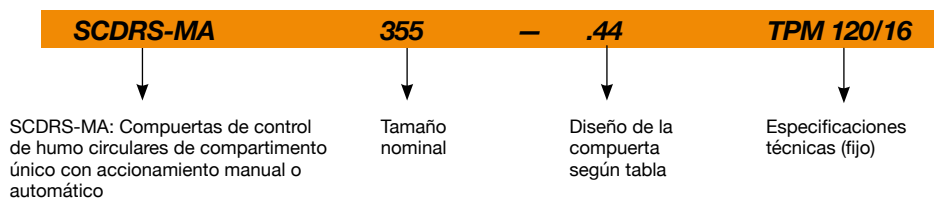

Diseño de la compuerta

Dígito adicional

Con actuador BEN a 230 V	.44
Con actuador BEN a 24 V	.54
Con actuador BEN-SR a 24 V	.65
Con el dispositivo de comunicación y alimentación BKNE 230-24 y el mecanismo de accionamiento BEN-ST para 24 V	.66

ÍNDICE ALFABÉTICO DE REFERENCIAS

BOXPRES PLUS	291
BOXPRES PLUS II	291
BOXSMART	271
BOXSMART EC	276
BOXSMART FLAP	281
BOXSMART II	271
CBDT	152
CHT	244
CHT/EC	248
CI	134
CJBDT	149
CJLINE	223
CJLINE/EC	227
CJMD	164
CJMP	193
CJS	161
CJSRX	216
CJSX	209
CJTCR/R	177
CJTCR/R/EW	182
CJTHT	112
CJTHT/ATEX	119
CJTHT/PLUS	107
CJTX-C	199
CJV/EW	155
CKD	232
CKDR	235
CKDR/EC	239
CVT	252
CVT/EC	256
HATCH PDS	266
HTMF	137
KIT BOXPDS	260
KIT BOXPDS II	260
KIT BOXPDS SMART	263
KIT BOXPDS SMART II	263
KIT BOXPRES PLUS	287
KIT BOXSMART	269
KIT BOXSMART EC	274
KIT BOXSMART FLAP	278
KIT BOXSMART II	269
KIT SOBREPRESIÓN	283
PRESSKIT	289
TCMP	188
TCR	158
TCR/R	168
TCR/R/EW	172
THT	27
THT/CL	77
THT/HATCH	99
THT/IMP	125
THT/ROOF	145
THT/WALL	86
THT/WALL-F	94
TUNEL JET FAN	131

ACCESORIOS

ACE ACE/400	310
AET	300
B	303
BAC	305
BD	304
BIC	305
BOXPARK	294
BS	307
BSS	307
BTUB	303
C2V	297
CABLE BOX	298
CENTRAL CO	300
CM	311
DAMPER BOX	320
DAMPER BOX SMART	320
IAT	297
INT	297
INT/ATEX	297
MS	306
P-400	301
PA	307
PDS LOBBY CONTROL	318
PS	306
PT	308
PT/H	308
R/THT	302
RM	298
RPA	302
RT	301
S	312
SC	316
SCDLM-MA	323
SCDLS-MA	321
SCDRS-MA	322
SI-FUENTE DE ALIMENTACIÓN	317
SI-PIR	316
SI-PRESIÓN	317
SI-PRESOSTATO	317
SI-TEMP+HUMEDAD	316
SI-VENT	317
TAC	311
TEJ	311
VIS	309
VSD3/A-RFT - VSD1/A-RFM	299



HEADQUARTER

Sodeca, S.L.U.

Pol. Ind. La Barriconxa
Carrer del Metall, 2
E-17500 Ripoll
Girona, SPAIN
Tel. +34 93 852 91 11
Fax: +34 93 852 90 42
General sales: comercial@sodeca.com
Export sales: ventilation@sodeca.com

PRODUCTION PLANT

Sodeca, S.L.U.

Ctra. de Berga, km 0,7
E-08580 Sant Quirze de Besora
Barcelona, SPAIN
Tel. +34 93 852 91 11
Fax: +34 93 852 90 42
General sales: comercial@sodeca.com
Export sales: ventilation@sodeca.com

RED COMERCIAL ESPAÑA

Barcelona

Sr. Jesús Cuadras
Pol. Ind. La Barriconxa
Carrer del Metall, 2
E-17500 Ripoll
Girona, SPAIN
Tel. +34 93 852 91 11
Móvil: 639 077 346
jcuadras@sodeca.com
Provincias: Barcelona, Tarragona, Lleida y Girona

Baleares

Sr. Miquel Àngel Morán
Móvil: 682 912 100
baleares@sodeca.com
Provincias: Baleares

Bilbao

Pitalven S.L.
Sr. Jon Garin
Pza. Jaro de Arana, 3 4º
48012 Bilbao
Tel./Fax 94 421 42 23
Móvil: 615 749 646
jgarin@sodeca.com
Provincias: Vizcaya, Guipúzcoa, Álava, Santander, Navarra y Rioja

Canarias

Srta. Ana Terrones
Móvil: 676 340 543
canarias@sodeca.com
Provincias: Islas Canarias

A Coruña

Sr. Ricard Fernández
Rúa a Granxa, 2B (Lorbe)
15177 Oleiros
Tel./Fax 98 162 81 96
Móvil: 615 145 104
rfernandez@sodeca.com
Provincias: A Coruña, Lugo, Ourense y Pontevedra

Gijón

Sr. Alejandro Bernain
Tel. 93 852 91 11
Móvil: 689 804 734
asturias@sodeca.com
Provincias: Asturias y León

Madrid

Sr. José María de Bernardo
Pol.Ind. Miralcampo
Calle Aluminio, 12
19200 Azuqueca de Henares
Tel. 91 366 70 45 / 91 366 60 45
Móvil: 670 744 420
sodecacentro@sodeca.com
Provincias: Madrid, Toledo, Ciudad Real, Guadalajara, Segovia, Ávila y Cuenca

Murcia

Sr. Francisco José Hurtado
Apartado de Correos 6103
30080 Murcia
Tel. 675 767 025
hurtado@sodeca.com
Provincias: Murcia, Almería, Granada y Jaén

Sevilla

Sr. Manuel Zambrano
Pol.Ind. Los Llanos
Calle Extremadura, 169 F
41909 Salteras
Sevilla
Móvil: 606 663 814
mzambrano@sodeca.com
sevilla@sodeca.com
Provincias: Sevilla, Huelva, Cádiz, Córdoba, Málaga, Cáceres y Badajoz

Valencia

Tacifer S.L.
Sr. Javier Talens
Timoneda, 8, 1º
46008 Valencia
Tel. 96 384 14 80
Fax 96 382 02 07
Móvil: 670 696 289
javiertalens@sodeca.com
csebastian@sodeca.com
Provincias: Valencia, Castellón, Alicante y Albacete

Valladolid

Sr. Xavier Formentí
Tel. 93 852 91 11
Móvil: 679 559 099
sodecacastilla@sodeca.com
Provincias: Salamanca, Valladolid, Palencia, Burgos y Zamora

Zaragoza

Hernández Silbe S.L.
Srta. Silvia Hernández
Alfonso I, casa 15
50410 Cuarte de Huerva
Zaragoza
Tel. 630 263 224
Fax 97 693 74 30
sodecaragon@sodeca.com
Provincias: Huesca, Zaragoza, Teruel y Soria



EUROPE

FINLAND

Sodeca Finland, Oy
HUITTINEN
Sales and Warehouse
Mr. Kai Yli-Sipilä
Metsälinnankatu 26
FI-32700 Huitinen
Tel. + 358 400 320 125
orders.finland@sodeca.com

HELSINKI

Smoke Control Solutions
Mr. Antti Kontkanen
Viipulantie 9C
FI-00700 Helsinki
Tel. +358 400 237 434
akontkanen@sodeca.com

HYVINKÄÄ

Smoke extraction and industrial applications
Niinistökatu 12
FI-05800 Hyvinkää
Mr. Jaakko Tomperi
Tel. +358 451 651 333
jtomperi@sodeca.com
Mrs. Kaisa Partanen
Tel. +358 451 308 038
kpartanen@sodeca.com

ITALIA

Marelli Ventilazione, S.R.L.
Viale del Lavoro, 28
37036 San Martino B.A.
(VR), ITALY
Tel. +39 045 87 80 140
vendite@sodeca.com

PORTUGAL

Sodeca Portugal, Unip. Lda.
PORTO
Rua Veloso Salgado 1120/1138
4450-801 Leça de Palmeira
Tel. +351 229 991 100
geral@sodeca.pt

LISBOA

Pq. Emp. da Granja Pav. 29
2625-607 Vialonga
Tel. +351 219 748 491
geral@sodeca.pt

ALGARVE

Rua da Alegria, 33
8200-569 Ferreiras
Tel. +351 289 092 586
geral@sodeca.pt

UNITED KINGDOM

Sodeca Fans UK, Ltd.
Mr. Mark Newcombe
Tamworth Enterprise Centre
Philip Dix House, Corporation
Street, Tamworth, B79 7DN
UNITED KINGDOM
Tel. +44 (0) 1827 216 109
sales@sodeca.co.uk

AMERICA

CHILE

Sodeca Ventiladores, SpA.
Sra. Sofía Ormazábal
Santa Bernardita 12.005
(Esquina con Puerta Sur)
Bodegas 24 a 26,
San Bernardo, Santiago, CHILE
Tel. +56 22 840 5582
ventas.chile@sodeca.com

COLOMBIA

Sodeca Latam, S.A.S.
Sra. Luisa Stella Prieto
Calle7 No. 13 A-44
Manzana 4 Lote1, Montana
Mosquera, Cundinamarca
Bogotá, COLOMBIA
Tel. +57 1 756 4213
ventascolombia@sodeca.co

PERU

Sodeca Perú, S.A.C.
Sr. Jose Luis Jiménez
C/ Mariscal Jose Luis de Orbegoso 331. Urb. El pino.
15022, San Luis. Lima, PERÚ
Tel. +51 1 326 24 24
Cel. +51 994671594
comercial@sodeca.pe



HEADQUARTER

Sodeca, S.L.U.

Pol. Ind. La Barricona
Carrer del Metall, 2
E-17500 Ripoll
Girona, SPAIN
Tel. +34 93 852 91 11
Fax: +34 93 852 90 42
General sales: comercial@sodeca.com
Export sales: ventilation@sodeca.com

PRODUCTION PLANT

Sodeca, S.L.U.

Ctra. de Berga, km 0,7
E-08580 Sant Quirze de Besora
Barcelona, SPAIN
Tel. +34 93 852 91 11
Fax: +34 93 852 90 42
General sales: comercial@sodeca.com
Export sales: ventilation@sodeca.com



www.sodeca.com

